



Solis Techview APP

Ginlong Technologies Co., Ltd.

No. 57 Jintong Road, Binhai Industrial Park, Xiangshan, Ningbo,  
Zhejiang, 315712, P.R.China.

Tel: +86 (0)574 6578 1806

Fax: +86 (0)574 6578 1606

Email: info@ginlong.com

Web: www.ginlong.com

Please adhere to the actual products in case of any discrepancies in this user manual.

If you encounter any problem on the inverter, please find out the inverter S/N  
and contact us, we will try to respond to your question ASAP.

Importer: xxxx



This mark indicates compound UK product safety certification requirements.



## Solis AC Coupled 5G Inverter Instruction Manual

Ver 1.1

Ginlong Technologies Co., Ltd.

---

|   |    |
|---|----|
| <b>1. Introduction</b>                    | 2  |
| 1.1 Product Description                   | 2  |
| 1.2 Packaging                             | 3  |
| <b>2. Safety &amp; Warning</b>            | 4  |
| 2.1 Safety                                | 4  |
| 2.2 General Safety Instructions           | 4  |
| 2.3 Notice for Use                        | 5  |
| 2.4 Notice for Disposal                   | 5  |
| <b>3. Overview</b>                        | 6  |
| 3.1 Screen                                | 6  |
| 3.2 Keypad                                | 6  |
| 3.3 Terminal Connection                   | 6  |
| <b>4. Installation</b>                    | 7  |
| 4.1 Select a Location for the Inverter    | 7  |
| 4.2 Mounting the Inverter                 | 9  |
| 4.3 Assemble the Battery Cables           | 11 |
| 4.4 Assemble the AC Cables                | 12 |
| 4.5 External Residual Current Device(RCD) | 13 |
| 4.6 Meter/CT Installation                 | 14 |
| 4.7 Assemble Other Cables                 | 15 |
| 4.8 External Ground Connection            | 17 |
| 4.9 LED Indicates                         | 17 |
| 4.10 Inverter Monitoring Connection       | 18 |
| 4.11 Solis TechView Illustration          | 19 |
| <b>5. Operation</b>                       | 20 |
| 5.1 Main Menu                             | 20 |
| 5.2 Information                           | 20 |
| 5.3 Settings                              | 24 |
| 5.4 Advanced Info                         | 25 |
| 5.5 Advanced Settings                     | 27 |
| <b>6. Commissioning</b>                   | 36 |
| 6.1 Preparation of Commissioning          | 36 |
| 6.2 Commissioning Procedure               | 36 |
| <b>7. Maintenance</b>                     | 37 |
| <b>8. Troubleshooting</b>                 | 38 |
| <b>9. Specifications</b>                  | 41 |
| <b>10. Appendix</b>                       | 43 |

# 1. Introduction

## 1.1 Product Description

The Solis AC-Coupled inverter is used for upgrade the existing on-grid power generation system to a hybrid system which can work with batteries to optimize self-consumption.

The Solis AC-Coupled inverter model type:

RAI-3K-48ES-5G

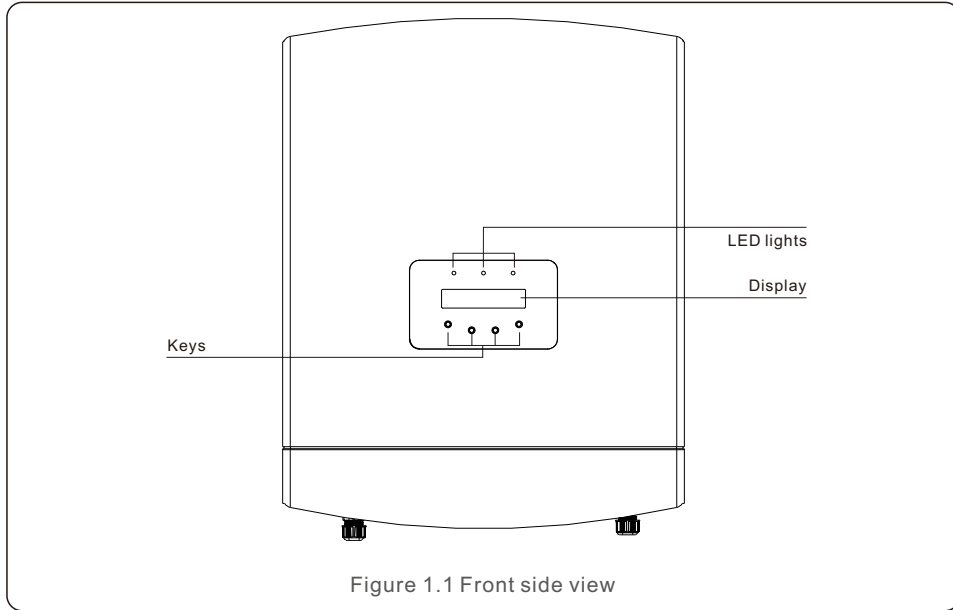

Figure 1.1 Front side view

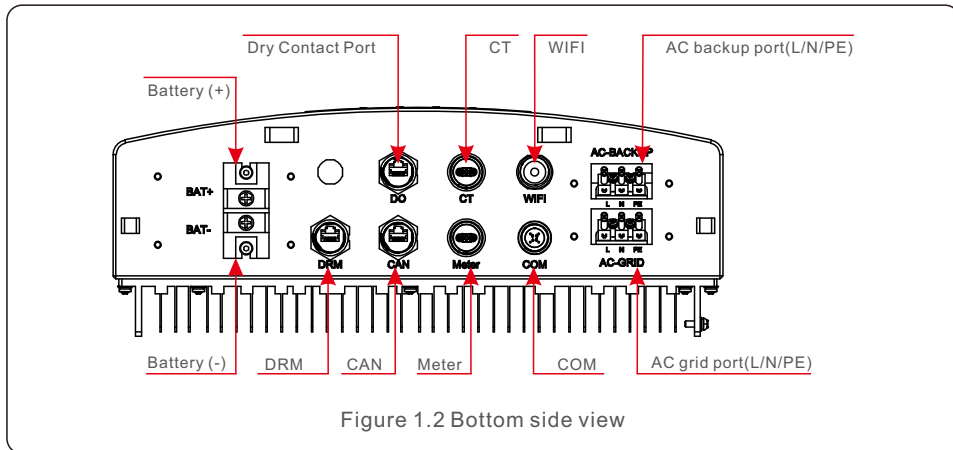
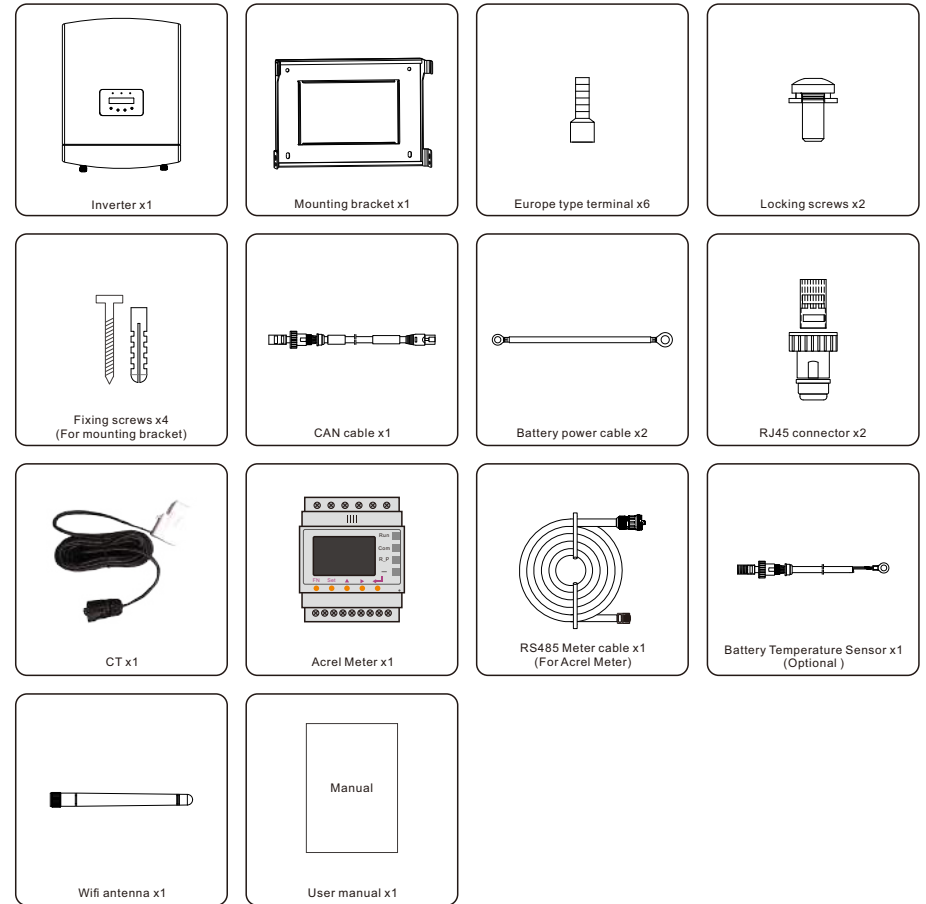

Figure 1.2 Bottom side view

# 1. Introduction

## 1.2 Packaging

Please ensure that the following items are included in the package along with your inverter:



If anything is missing, please contact your local Solis distributor.

# 2. Safety & Warning

## 2.1 Safety

The following types of safety instructions and general information appear in this document as described below:



**DANGER:**

“Danger” indicates a hazardous situation which if not avoided, will result in death or serious injury.



**WARNING:**

“Warning” indicates a hazardous situation which if not avoided, could result in death or serious injury.



**CAUTION:**

“Caution” indicates a hazardous situation which if not avoided, could result in minor or moderate injury.



**NOTE:**

“Note” provides tips that are valuable for the optimal operation of your product.

## 2.2 General Safety Instructions



**WARNING:**

Only devices in compliance with SELV (EN 69050) may be connected to the RS485 and USB interfaces.



**WARNING:**

Please don't connect positive (+) or negative (-) cable to ground, it could cause serious damage to the inverter.



**WARNING:**

Electrical installations must be done in accordance with the local and national electrical safety standards.



**WARNING:**

Do not touch any inner live parts until 7 minutes after disconnection from the utility grid and the DC input.

# 2. Safety & Warning



**CAUTION:**

Risk of electric shock, do not remove cover. There is no user serviceable parts inside, refer servicing to qualified and accredited service technicians.



**CAUTION:**

Risk of electric shock from energy stored in capacitors of the Inverter, do not remove cover for 7 minutes after disconnecting all power sources (service technician only). Warranty may be voided if the cover is removed without authorization .



**CAUTION:**

The surface temperature of the inverter can reach up to 75°C (167 F). To avoid risk of burns, do not touch the surface of the inverter while it's operating. Inverter must be installed out of the reach of children.



**WARNING:**

Operations below must be accomplished by licensed technician or Solis authorized person.



**WARNING:**

Operator must put on the technicians' gloves during the whole process in case of any electrical hazards.

## 2.3 Notice for Use

The inverter has been constructed according to the applicable safety and technical guidelines. Use the inverter in installations that meet the following specifications ONLY:

1. Permanent installation is required.
2. The electrical installation must meet all the applicable regulations and standards.
3. The inverter must be installed according to the instructions stated in this manual.
4. The inverter must be installed according to the correct technical specifications.

## 2.4 Notice for Disposal

This product shall not be disposed of with household waste. They should be segregated and brought to an appropriate collection point to enable recycling and avoid potential impacts on the environment and human health. Local rules in waste management shall be respected .



# 3. Overview

## 3.1 Screen

Solis AC-Coupled inverter adopts LCD screen, it displays the status, operating information and settings of the inverter.

## 3.2 Keypad

There are four keys on the front panel of the inverter (from left to right): ESC, UP, DOWN and ENTER keys. The keypad is used for:

- Scrolling through the displayed options (the UP and DOWN keys);
- Access and modify the settings (the ESC and ENTER keys).



Figure 3.1 Keypad

## 3.3 Terminal Connection

Solis AC-Coupled inverter is different from normal on-grid inverter, please refer to the instructions below before start connection.



**WARNING:**

Please refer to the specification of the battery before configuration.

# 4. Installation

## 4.1 Select a Location for the Inverter

To select a location for the inverter, the following criteria should be considered:

- Exposure to direct sunlight may cause output power derating. It is recommended to avoid installing the inverter in direct sunlight.
- It is recommended that the inverter is installed in a cooler ambient which doesn't exceed 104°F/40°C.

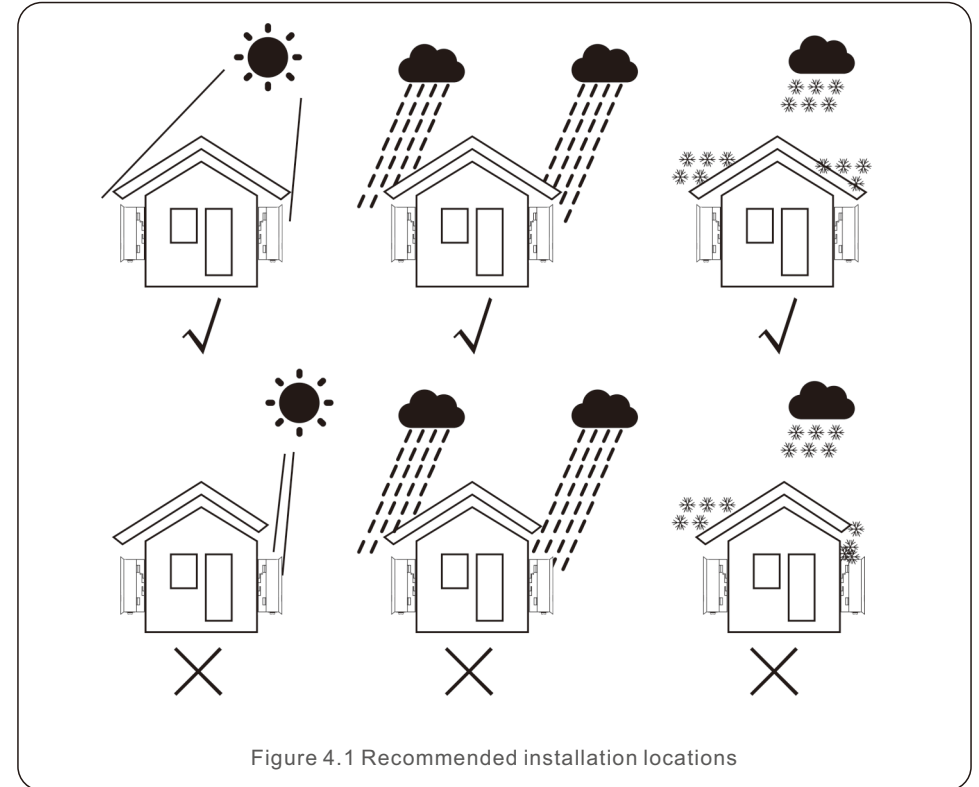

Figure 4.1 Recommended installation locations



**WARNING: Risk of fire**

Despite careful construction, electrical devices can cause fires.

- Do not install the inverter in areas containing highly flammable materials or gases.
- Do not install the inverter in potentially explosive atmospheres.

# 4. Installation

- Install on a wall or strong structure capable of bearing the weight of the inverter (12.1kg).
- Install vertically with a maximum incline of +/- 5 degrees, exceeding this may cause output power derating.
- To avoid overheating, always make sure the flow of air around the inverter is not blocked. A minimum clearance of 300mm should be kept between inverters or objects and 500mm clearance between the bottom of the inverter and the ground.

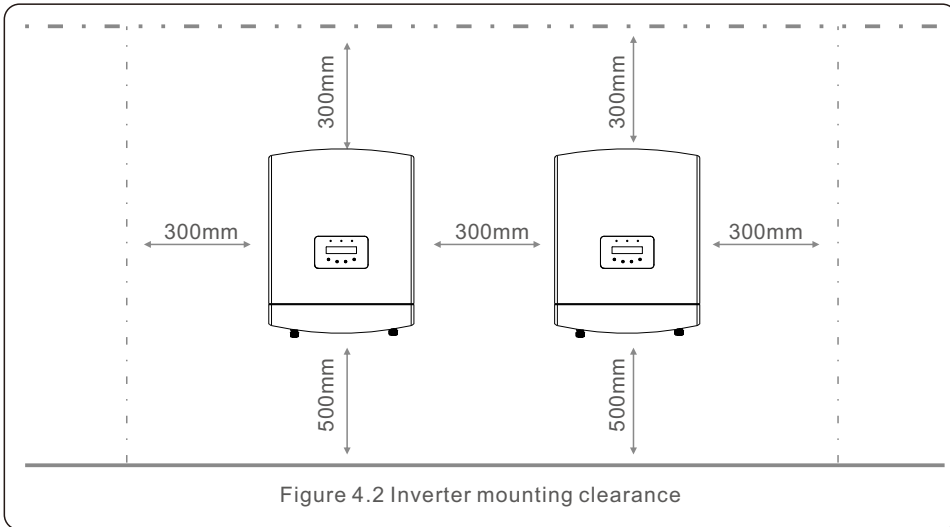

- Visibility of the LEDs and LCD should be considered.
- Adequate ventilation must be provided.



**NOTE:**

Nothing should be stored on or placed against the inverter.



**NOTE:**

During installation, consider whether the noise emitted in that particular environment might exceed the legal thresholds (less than 70 dBA); if so, suitable ear protection must be worn. Do not install rooms where people live or where the prolonged presence of people or animals is expected, because of the noise (around 35 dBA at 1m) that the inverter produces during operation.

# 4. Installation

## 4.2 Mounting the Inverter

Dimensions of mounting bracket:

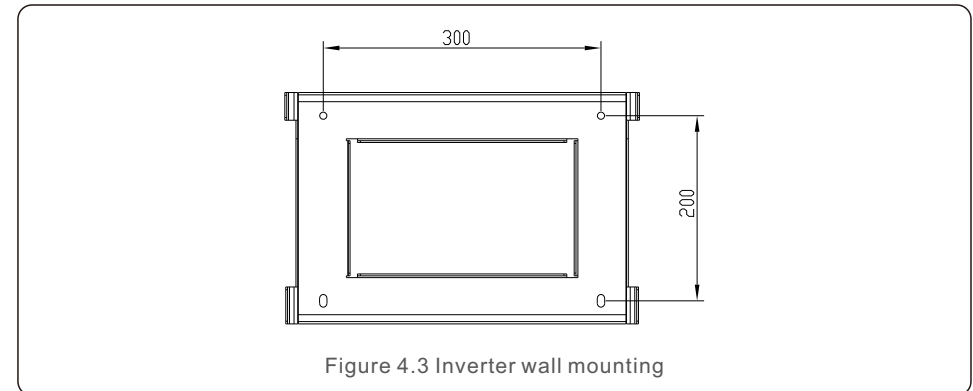

Once a suitable location has been found according to 4.1, please refer to figure 4.3 and figure 4.4 and mount the wall bracket to the wall.

The inverter shall be mounted vertically.

The steps to mount the inverter are listed below:

1. Select the mounting height of the bracket and mark the mounting holes.

For brick walls, the position of the holes should be suitable for the expansion bolts.

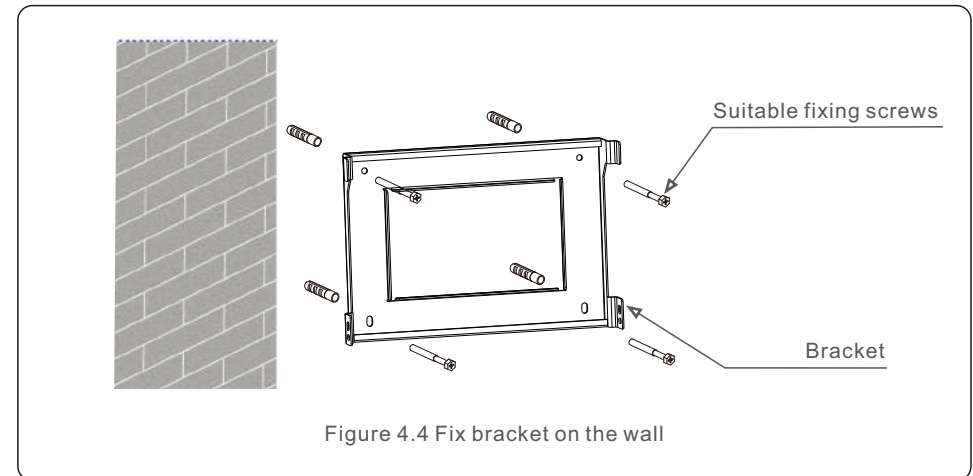

**WARNING:**

The inverter must be mounted vertically.

# 4. Installation

2. Lift up the inverter (be careful to avoid body strain), and align the back bracket on the inverter with the convex section of the mounting bracket. Hang the inverter on the mounting bracket and make sure the inverter is secured (see Figure 4.5)

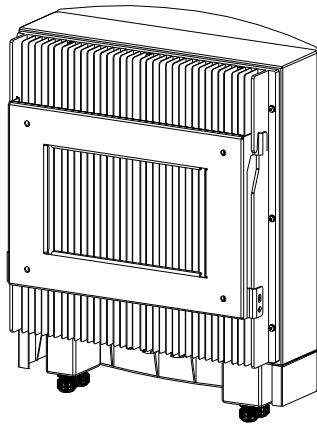

Figure 4.5 Wall mount bracket

Please make sure to remove the cover at the bottom of the inverter before assembling the terminals.

Remove the cover as shown in the picture and follow the direction to lift the cover, make sure the buckles on the left and right sides are correctly loosened.

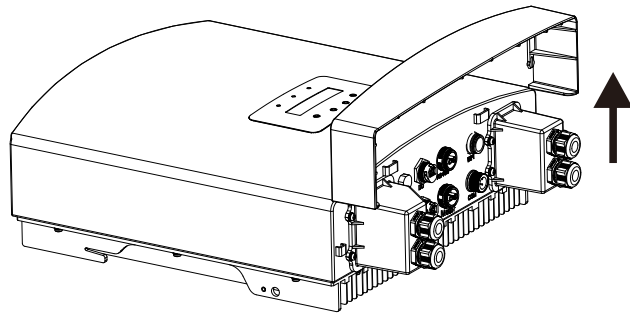

Figure 4.6 Remove the cover

# 4. Installation

## 4.3 Assemble the Battery Cables



**WARNING:**

Incorrect polarity of the battery cable may lead to permanent damage on the device.



**WARNING:**

To avoid DC arc, Solis recommends installing DC breaker (Rated current > 80A) between batteries and the AC coupled inverter. Ensure the correct polarity of batteries before connecting to the inverter.

Step 1. Please unlock the 4\*M4 screws on the battery port protection cover as shown in the below figure.

Step 2. Insert the battery power cables (in package) into the water-proof swivel nut on the cover, (Break the plastic film on it).

Step 3. Fasten the battery power cables onto the BAT+ and BAT- terminals on the inverter. Please make sure the labels on cable and inverter match up.

Step 4. Lock the 4\*M4 screws and fix the cover onto the inverter.

Step 5. Connect the other side of the battery power cables to the battery.

M4 cross screws

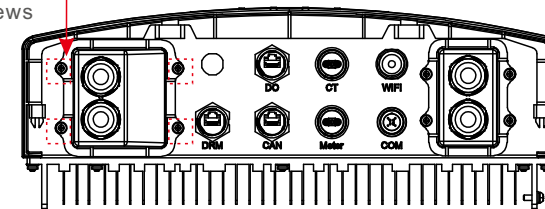

Figure 4.7

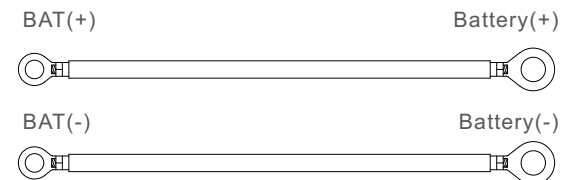

Figure 4.8

# 4. Installation

# 4. Installation

## 4.4 Assemble the AC Cables

There are two AC terminals and the assembly steps for both are the same (AC backup port and AC grid port).

Step 1. Please unlock the 4\*M4 screws on the AC ports protection cover as shown in the below figure.

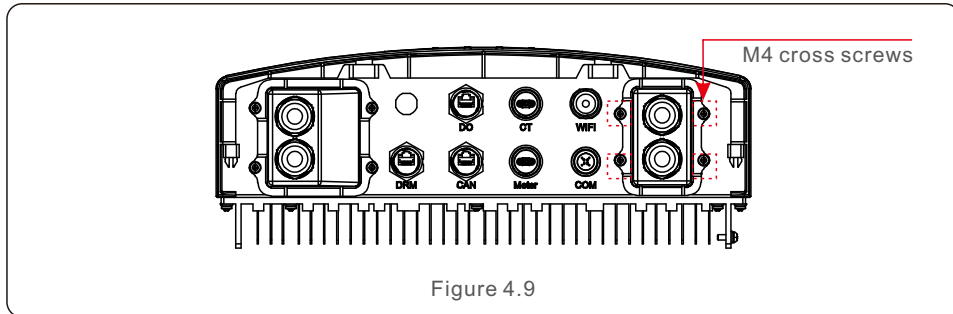

Figure 4.9

Step 2. Insert the AC grid cables and AC backup cables into the corresponding water-proof swivel nut on the cover, (Break the plastic film on it). Make sure you use a cable within the correct specifications as shown in the table below.

Remove a length of 40mm of the cable jacket and strip the wire insulation to a length of 10-12mm. Use the Euro type connectors for connecting with the stripped area of AC Grid and AC backup.

| Describe                      | Numerical value  |
|-------------------------------|------------------|
| Wire diameter                 | 6~12mm           |
| Traverse cross sectional area | 6mm <sup>2</sup> |
| Exposure Length               | 12mm             |

Table 4.1

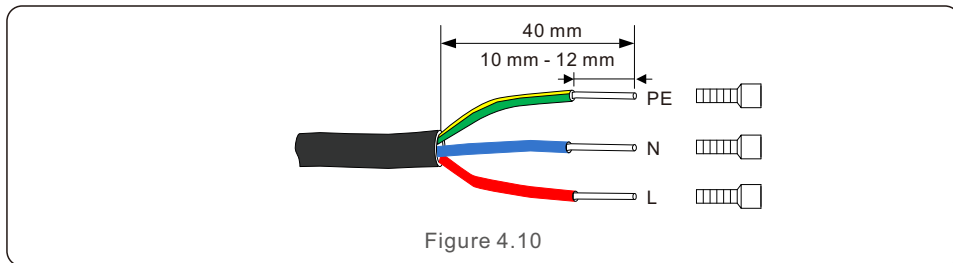

Figure 4.10

Step 3. Fasten the AC cables onto the terminals on the inverter. Please make sure the correct polarity. Ensure that the correct conductor is fastened (0.7 N.m. torque) to the correct terminal.

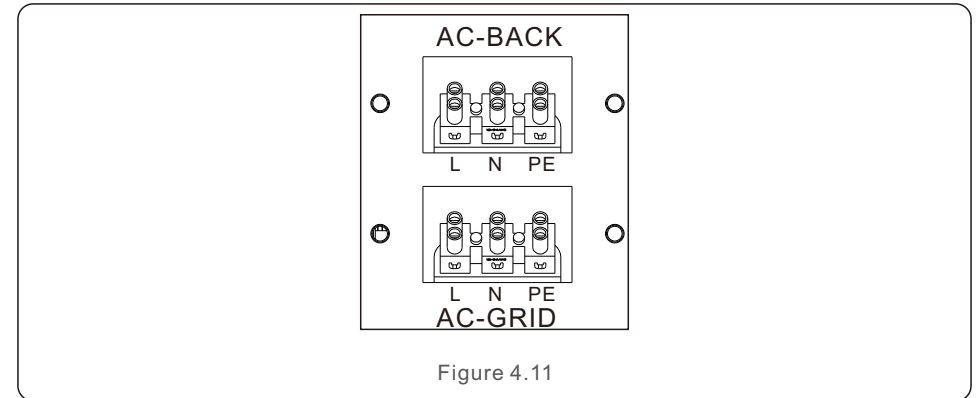

Figure 4.11



**WARNING:**

Observe the terminal layout of terminal block. Do not connect the phase lines to "PE" terminal, otherwise the inverter will not function properly.



**NOTE:**

It is suggested to install AC breakers for the AC Grid and AC Backup circuits. Recommended AC Breaker rating for AC Grid circuit is 35A and recommended AC Breaker rating for AC Backup circuit is 25A.

Step 4. Lock the 4\*M4 screws and fix the cover onto the inverter.

## 4.5 External Residual Current Device(RCD)

All series of Solis inverters are integrated with an internal residual current device to protect against any potential d.c component and a.c component of residual current.

Therefore, all Solis inverters, due to the design, are not able to feed in DC fault current to the system which fully complies with IEC60364-7-712.

If an external RCD is required to be installed by local regulations, Solis recommends installing a Type-A RCD with a threshold current higher than 100mA.



# 4. Installation

## 4.6 Meter/CT Installation

RAI-3K-48ES-5G inverter requires a smart meter to measure the power flow at the grid connection point to achieve the self-use control algorithm. The smart meter and the communication cable are provided as a standard accessory in the package. Please refer to below system diagram to connect the smart meter at the grid connection point. Meanwhile, a smart CT sensor is provided in order to measure the generation of grid-tied PV inverter.

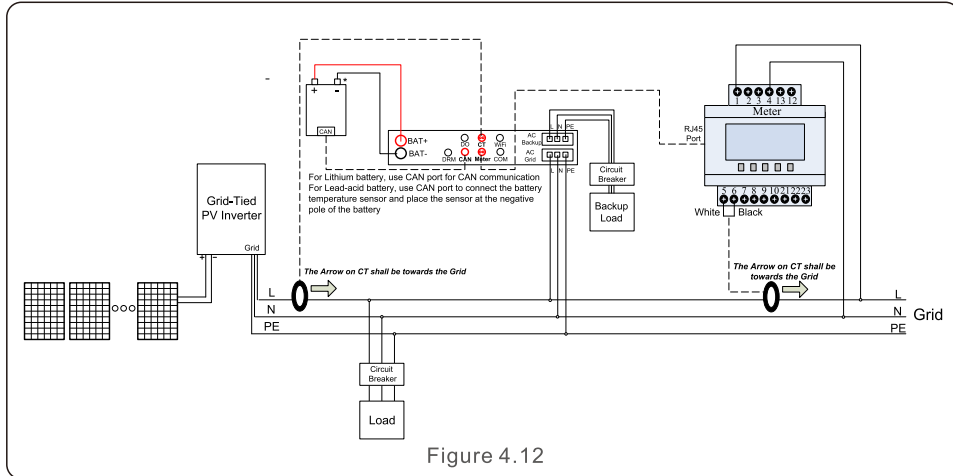

Figure 4.12

Smart Meter for grid power flow measurement (External CT provided within the meter package).

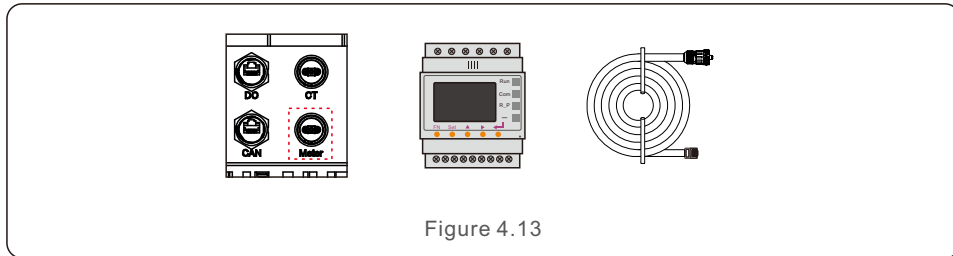

Figure 4.13

Smart CT sensor for PV generation measurement.

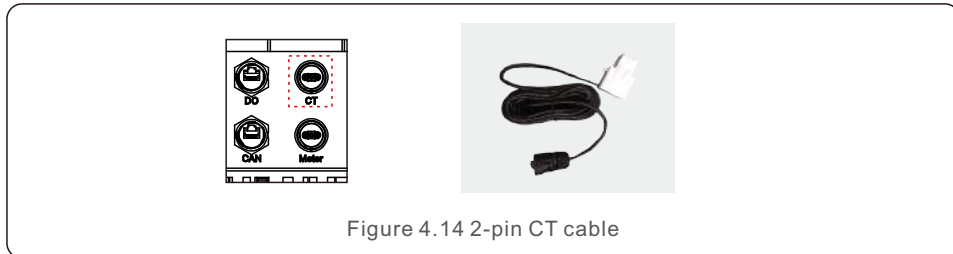

Figure 4.14 2-pin CT cable

# 4. Installation

## 4.7 Assemble Other Cables

### 1. Battery CAN communication cable

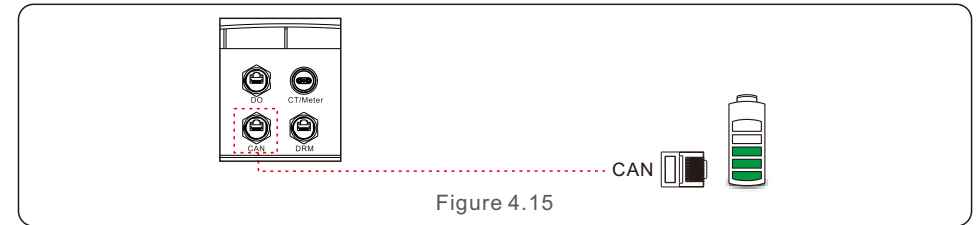

Figure 4.15



**NOTE:**

The CAN cable enables the communication between the inverter and the Li-ion battery from BYD, PYLON, etc. Please check for latest model compatibility before installation.

- Step 1. Take out the CAN cable (terminal marks 'CAN' on one end and 'to Battery' on the other end).
- Step 2. Unscrew the swivel nut from CAN port.
- Step 3. Insert the RJ45 terminal with CAN label into the CAN port, then fasten the swivel nut.
- Step 4. Connect the other end to the battery.



**NOTE:**

Before connecting CAN cable with the battery, please check whether the communication pin sequence of the inverter and the battery match; If it does not match, you need to cut off the RJ45 connector at one end of the CAN cable and adjust the pin sequence according to the pin definitions of both inverter and battery.

Pin definition of the inverter CAN Port is following EIA/TIA 568B.

- CAN-H on Pin 4: Blue
- CAN-L on Pin 5: Blue/White

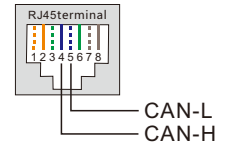

**NOTE:**

Lead-Acid and other older-technology battery types require experienced and precise design, installation and maintenance to work effectively. For RHI series inverters there is no temperature compensation, thus client need BTS (battery temperature sensor) which is connected to CAN port at one side and battery negative pole at the other side. BTS is optional. For further information please contact the sales manager. For lead-acid battery, battery SOC calculation may not be accurate according to battery in conformity between cells, battery aging or other specifications of lead-acid battery etc.

# 4. Installation

## 2. Logic interface communication cable

Logic interface is required by some local regulations that can be operated by a simple switch or contactor(Not available in South Africa).  
 When the switch is closed the inverter can operated normally. When the switch is opened, the inverter will reduce it's output power to zero within 5s.  
 Pin5 and Pin6 of RJ45 terminal is used for the logic interface connection.  
 Please follow below steps to assemble RJ45 connector.

Step 1: Insert the network cable into the communication connection terminal of RJ45.

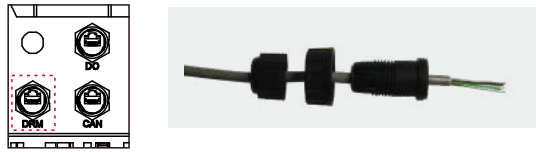
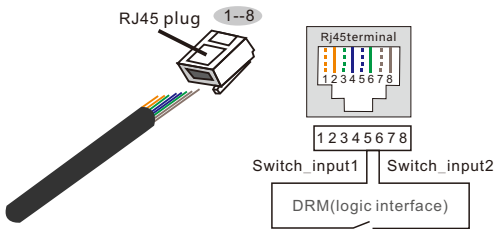

Figure 4.16 RJ45 communication connection terminals

Step 2: Use the network wire stripper to strip the insulation layer of the communication cable. According to the standard line sequence of figure 4.17 connect the wire to the plug of RJ45, and then use a network cable crimping tool to make it tight.



**Correspondence between the cables and the stitches of plug, Pin5 and Pin6 of RJ45 terminal is used for the logic interface, other Pins are reserved.**  
 Pin 1: Reserved; Pin 2: Reserved  
 Pin 3: Reserved; Pin 4: Reserved  
 Pin 5: Switch\_input1; Pin 6: Switch\_input2  
 Pin 7: Reserved; Pin 8: Reserved

Figure 4.17 Strip the insulation layer and connect to RJ45 plug

Step 3: Connect RJ45 to DRM port (logic interface) .



**NOTE:**

To use this function, please contact the manufacturer.

# 4. Installation

## 4.8 External Ground Connection

An external ground connection is provided at the right side of inverter.

Prepare OT terminals: M4. Use proper tooling to crimp the lug to the terminal.  
 Connect the OT terminal with grounding cable >6mm<sup>2</sup> to the right side of the inverter.  
 The torque is 2N.m.

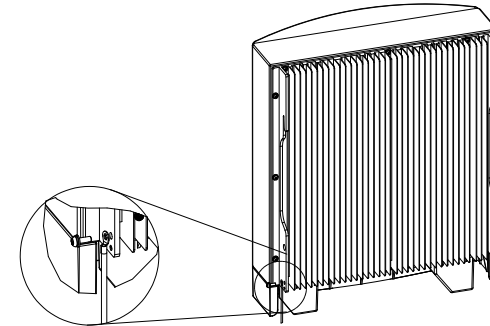

Figure 4.18 Connect the external grounding conductor

## 4.9 LED Indicates

There are three LED indicators on the Solis AC Coupled inverter (Red, Green, and Orange) which indicate the working status of the inverter.



| Light       | Status   | Description                         |
|-------------|----------|-------------------------------------|
| ● POWER     | ON       | The inverter can detect DC power.   |
|             | OFF      | No DC power.                        |
| ● OPERATION | ON       | The inverter is fully operational.  |
|             | OFF      | The inverter has stopped operating. |
|             | FLASHING | The inverter is initializing.       |
| ● ALARM     | OFF      | No fault condition detected.        |
|             | FLASHING | Fault condition is detected.        |

Table 4.2 Status indicator lights

# 4. Installation

## 4.10 Inverter Monitoring Connection

The inverter can be monitored via Wi-Fi or GPRS. All Solis communication devices are optional. For connection instructions, please refer to the Solis Monitoring Device installation manuals.

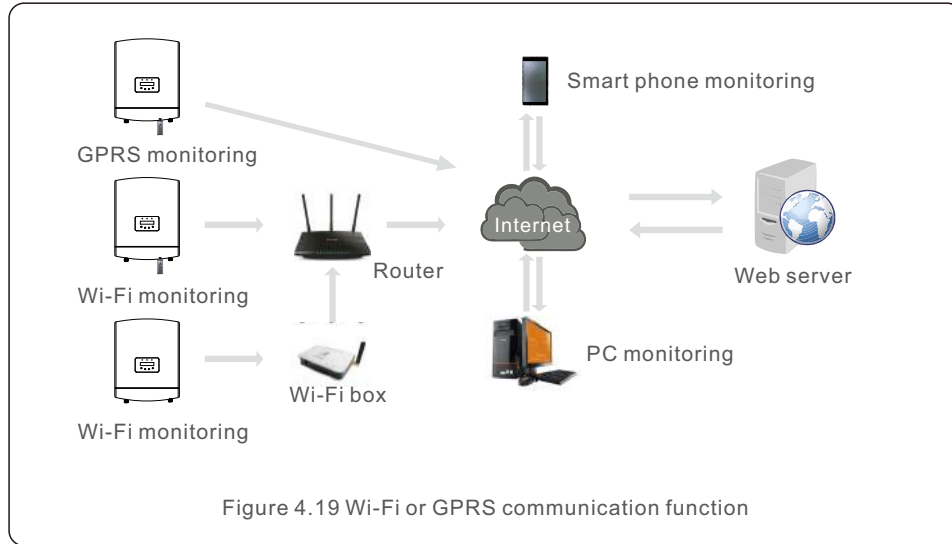

# 4. Installation

## 4.11 Solis TechView Illustration

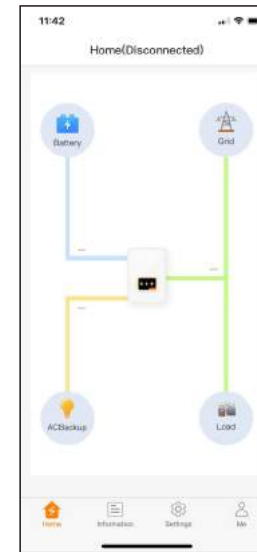
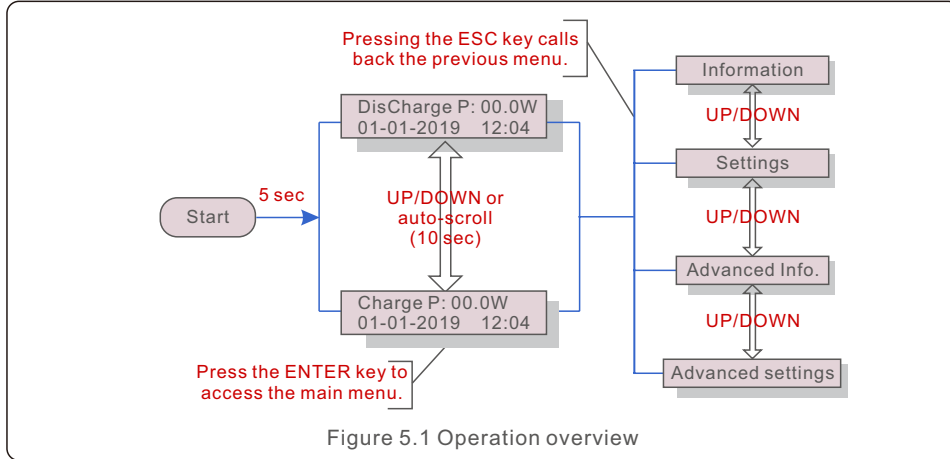

Figure 4.20

RAI series inverter can be controlled by LCD or APP (Solis TechView). For IOS system, please go to AppStore to search for "Solis TechView", then download and install it. For Android system, please go to Google Play to search for "Solis TechView", then download and install it. Besides, it can be also installed by scanning the QR code on the back cover of this manual.

To use the APP to control the inverter, you need to make sure the inverter is operating and then use your mobile device to connect the WiFi signal of the inverter (Factory defaults is Solis - inverter SN, and initial password is solis100. If any questions, please refer to Solis TechView quick guide). Then, you can enter the APP to view the information and change the settings of the inverter.

During normal operation, the display alternately shows the power and the operation status with each screen lasting for 10 seconds (see Figure 5.1). Screens can also be scrolled manually by pressing the UP and DOWN keys. Press the ENTER key to access to the Main Menu.



## 5.1 Main Menu

There are four submenus in the Main Menu (see Figure 5.1):

1. Information
2. Settings
3. Advanced Info.
4. Advanced Settings

## 5.2 Information

The Solis AC-Coupled Inverter main menu provides access to operational data and information. The information is displayed by selecting "Information" from the menu and then by scrolling up or down.

There are 6 submenus in the Information :

1. General Info
2. Syetem Info
3. Energy Records
4. BMS Info
5. Meter Info
6. CT Info

| Display                        | Description                       |
|--------------------------------|-----------------------------------|
| Inverter SN:<br>FFFFFFFFFFFFFF | Series number of the inverter.    |
| Device:<br>Waiting             | Device Status.                    |
| Battery:<br>Waiting            | Battery Status.                   |
| Backup:<br>Waiting             | Backup Status.                    |
| Grid:<br>Waiting               | Grid Status.                      |
| DRMNO.:<br>08                  | DRM No.                           |
| Model.:<br>00                  | Model number of the inverter.     |
| SoftVer.:<br>090000            | Firmware version of the inverter. |

Figure 5.2 Information list (General Info)

| Display                    | Description      |
|----------------------------|------------------|
| Grid Power:<br>+000000W    | Grid Power.      |
| Grid Voltage:<br>000.0V    | Grid Voltage.    |
| Grid Frequency:<br>00.00Hz | Grid Frequency.  |
| Battery Voltage:<br>000.0V | Battery Voltage. |
| Backup Voltage:<br>000.0V  | Backup Voltage.  |

Figure 5.3 Information list (System Info)

# 5. Operation

# 5. Operation

| Display                              | Description              |
|--------------------------------------|--------------------------|
| Backup Power:<br>00.0W               | Backup Power.            |
| Charge P:<br>00.0kW                  | Battery Charge Power.    |
| DisCharge P:<br>00.0kW               | Battery Discharge Power. |
| Battery Temperature :<br>+000.00degC | Battery Temperature.     |

Figure 5.4 Information list (System Info)

| Display                          | Description                         |
|----------------------------------|-------------------------------------|
| BattChgE Total:<br>0000000kWh    | Total battery charge energy.        |
| BattChgE Today:<br>000.0kWh      | Today battery charge energy.        |
| BattChgE Lastday:<br>000.0kWh    | Yesterday battery charge energy.    |
| BattDisChgE Total:<br>0000000kWh | Total battery discharge energy.     |
| BattDisChgE Today:<br>000.0kWh   | Today battery discharge energy.     |
| BattDisChgE Lastday:<br>000.0kWh | Yesterday battery discharge energy. |
| GridGetE Total:<br>0000000kWh    | Total energy imported from grid.    |
| GridGetE Today:<br>000.0kWh      | Today energy imported from grid.    |

Figure 5.5 Information list (Energy Records)

| Display                         | Description                          |
|---------------------------------|--------------------------------------|
| GridGetE Lastday:<br>000.0kWh   | Yesterday energy imported from grid. |
| Grid SendE Total:<br>0000000kWh | Total energy exported to grid.       |
| Grid SendE Today:<br>000.0kWh   | Today energy exported to grid.       |
| Grid SendE Lastday:<br>000.0kWh | Yesterday energy exported to grid.   |
| Backup Total:<br>0000000kWh     | Total backup consumption.            |
| Backup Today:<br>000.0kWh       | Today backup consumption.            |
| Backup Lastday:<br>0000000kWh   | Yesterday backup consumption.        |

Figure 5.6 Information list (Energy Records)

| Display                                     | Description                                  |
|---|--|
| Battery V: 00.00V<br>Battery I: +00.0A      | Battery voltage and current.                 |
| Charge Lmt: 000.0A<br>Discharge Lmt: 000.0A | Battery charge/discharge current limitation. |
| SOC Value: 000%<br>SOH Value: 000%          | SOC and SOH of battery.                      |
| BMS Status:<br>CAN Fail                     | BMS communication status.                    |

Figure 5.7 Information list (BMS Info)

| Display                | Description    |
|------------------------|----------------|
| Meter Voltage:<br>Null | Meter Voltage. |
| Meter Current:<br>Null | Meter Current. |
| Meter Power:<br>Null   | Meter Power.   |
| Meter Energy:<br>Null  | Meter Energy.  |
| Output Energy:<br>Null | Output Energy. |
| Input Energy:<br>Null  | Input Energy.  |
| Meter Status:<br>Null  | Meter Status.  |

Figure 5.8 Information list (Meter Information)

| Display                    | Description      |
|----------------------------|------------------|
| Grid-CT Voltage:<br>000.0V | Grid-CT Voltage. |
| Grid-CT Current:<br>00.00A | Grid-CT Current. |
| Grid-CT Power:<br>+00.0kW  | Grid-CT Power.   |

Figure 5.9 Information list (CT Information)

## 5.3 Settings

The following submenus are displayed when the Settings menu is selected:

1. Set Time/Date
2. Set Address

### 5.3.1 Set Time/Date

This function allows time and date setting. When this function is selected, the LCD will display as shown in Figure 5.10.

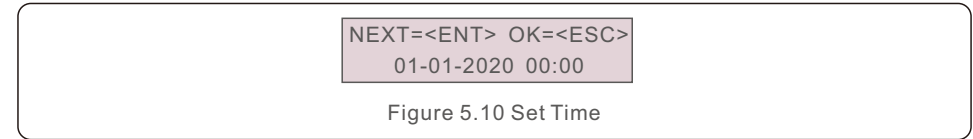

### 5.3.2 Set Address

This function is used for set the address when multiple inverters are connected to single monitor.

The address number can be assigned from "01" to "99". The default address number is "01".

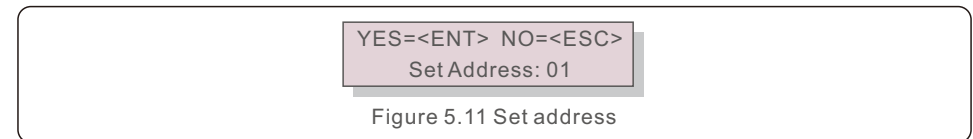

## 5.4 Advanced Info



### NOTE:

To access to this area is for fully qualified and accredited technicians only. Enter menu "Advanced Info." and "Advanced settings" (need password).

Select "Advanced Info." from the Main Menu.

The screen will require the password as below:

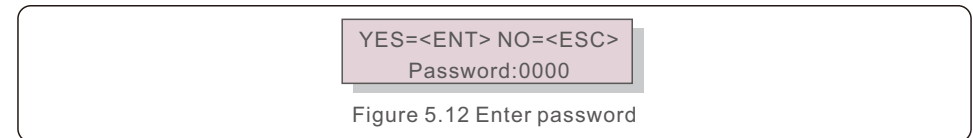

The default password is "0010". Please press "down" to move the cursor, press "up" to select the number.

After entering the correct password the Main Menu will display a screen and be able to access to the following information.

1. Alarm Message
2. Warning Message
3. Running Status
4. Communication Data
5. Yield Profile

# 5. Operation

## 5.4.1 Alarm Message

The display shows the 100 latest alarm messages.

Alarm000: ACOvercurrent  
T: 00-00 00:00 D: 0000

Figure 5.13 Alarm message

## 5.4.2 Warning Message

The display shows the 100 latest warning messages.

Msg000:  
T: 00-00 00:00 D: 0000

Figure 5.14 Warning message

## 5.4.3 Running Status

This function is for maintenance person to get running message.

General status includes: DC bus voltage, power factor, power limit, inverter temperature, grid standard

Advanced status includes: Control word status, Grid filter No., Ground voltage, etc.

→ General Status  
Advanced Status

Figure 5.15 Running status

## 5.4.4 Communication Data

The screen shows the internal data of the Inverter, which is for service technicians only.

01-05: 00 00 00 00 00  
06-10: 00 00 00 00 00

Figure 5.16 Communication data

## 5.4.5 Yield Profile

The section shows the energy records of the battery, grid, load and backup port.

→ Energy Battery  
Energy Grid

Figure 5.17 Yield profile

# 5. Operation

## 5.5 Advanced Settings



### NOTE:

To access to this area is for fully qualified and accredited technicians only. Please follow 5.4 to enter password to access this menu.

Select Advanced Settings from the Main Menu to access the following options:

1. Select Standard
2. Grid Switches
3. Battery Control
4. Backup Control
5. Storage Energy Set
6. STD. Mode Settings
7. Software Update
8. Export Power Set
9. Reset Password
10. Restart HMI
11. Self Test CEI 0-21
12. Compensation Set

### 5.5.1 Selecting Standard

This function is used for select the grid's reference standard.

YES=<ENT> NO=<ESC>  
Standard: G98

Figure 5.18 Selecting standard



### NOTE:

This function is for technicians use only.

Selecting the "User-Def" menu will access to the following submenu.

→ OV-G-V1: 260V  
OV-G-V1-T: 1S

Figure 5.19



### NOTE:

The " User-Def" function can be only used by the service engineer and must be allowed by the local energy supplier.

Below is the setting range for "User-Def". Using this function, the limits can be changed manually.

|                     |                               |
|---------------------|-------------------------------|
| OV-G-V1: 240---270V | OV-G-F1: 50.2-53Hz(60.2-63Hz) |
| OV-G-V1-T: 0.1---9S | OV-G-F1-T: 0.1---9S           |
| OV-G-V2: 240---300V | OV-G-F2: 50.2-53Hz(60.2-63Hz) |
| OV-G-V2-T: 0.1---1S | OV-G-F2-T: 0.1---9S           |
| UN-G-V1: 170---210V | UN-G-F1: 47-49.5Hz(57-59.5Hz) |
| UN-G-V1-T: 0.1---9S | UN-G-F1-T: 0.1---9S           |
| UN-G-V2: 110---210V | UN-G-F2: 47-49Hz(57-59.5Hz)   |
| UN-G-V2-T: 0.1---1S | UN-G-F2-T: 0.1---9S           |
| Startup-T:10---600S | Restore-T:10---600S           |

## 5.5.2 Grid Switches

This function is used for start up or stop working.

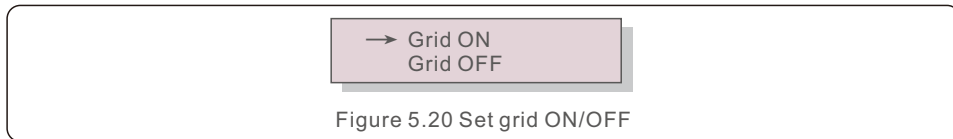

Figure 5.20 Set grid ON/OFF

## 5.5.3 Battery Control

This function is used for set the battery.

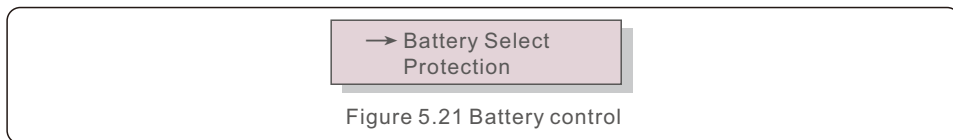

Figure 5.21 Battery control

### 5.5.3.1 Battery Select

There are some options(1. Lead Acid 2. No Battery 3. Pylon 4. User-Def 5. BYD 6. LG) about battery modules. When some battery module is selected, pre-settings will be imported, user doesn't need to configure the battery parameters except for over discharge SOC and forced charge SOC.

### 5.5.3.1 Battery Select

This product is compatible with the following battery modules:

| Brand              | Model  | Setting            |
|--------------------|--|--------------------|
| BYD                | Box Pro 2.5-13.8   | Select "B-BOX"     |
| LG Energy Solution | RESU 3.3/6.5/10/13   | Select "LG Chem"   |
| Pylontech          | US2000(CEI 0-21)/US3000(CEI 0-21)/ForceL1(CEI 0-21)/ForceL2(CEI 0-21)/Phantom-S/US2000C/US3000C/UP5000 | Select "Pylon"     |
| Dyness             | Powerdepot/Powerbox/B4850  | Select "Dyness"    |
| Puredrive          | 48V-100Ah  | Select "Puredrive" |
| Jiawei             | Home E11   | Select "Jiawei"    |
| Soluna             | 4K PACK  | Select "Soluna"    |
| Highstar           | HSD5870  | Select "Highstar"  |
| FOX                | LV5200   | Select "FOX"       |

When some battery module is selected, pre-settings will be imported, user doesn't need to configure the battery parameters except for over discharge SOC and forced charge SOC.

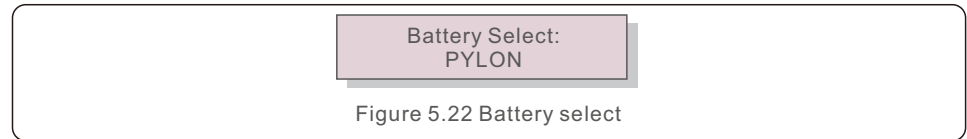
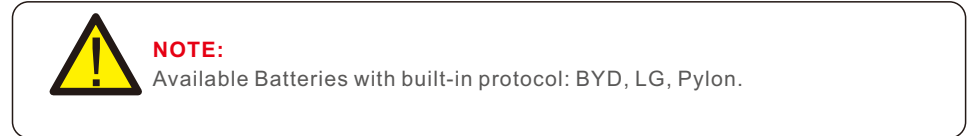

Figure 5.22 Battery select

The OverDischg SOC can be set from 10% to 40%.  
The ForceChagre SOC can be set from 5% to OverDischg SOC.

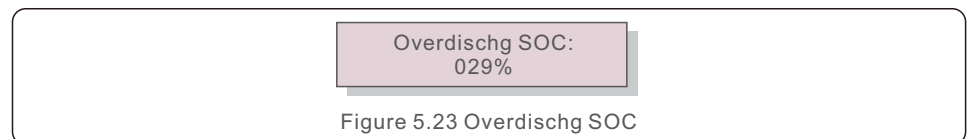

Figure 5.23 Overdischg SOC





**NOTE:**

5G products support lead-acid battery. Select "Lead-Acid" in the "Battery Select" and configure the following parameters according to different lead-acid batteries.

1. Battery Capacity :Define the capacity of the battery.
2. I\_Max Discharge: Define the max discharge current.
3. I\_Max Charge: Define the max charge current.
4. Equalizing Voltage: Define the voltage of equalizing charge.
5. Floating Voltage :Define the voltage of floating charge.
6. Floating Current :Define the current of floating charge.
7. Overdischg Voltage: the min voltage that the battery can be discharged.
8. Force Charg Voltage: the min voltage that the battery will be force charged against the self-discharge of the battery.
9. Temp.Compensation:the value shall be set according to lead-acid specification.
10. Environment Temp.:If there is NTC,the option is not necessary to define(Warm/Hot/Cold).  
After configuration, save and send. Select the Environment Temp based on real condition.(Norm/Cold/Hot)



**WARNING:**

Lead-acid battery is not recommended for general customers as it requires experienced installers and technicians who can fully understand the battery parameters and configure the settings and installations correctly. Due to the inconformity between battery cells, damages will be less likely to be avoided. Solis is not responsible for any potential damages caused by the use of lead-acid batteries.

### 5.5.3.2 Protection

Define Battery over voltage(46V~62V) and Under voltage(40V~48V).

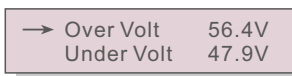

Figure 5.24 Define battery overvoltage limit and under voltage

### 5.5.3.3 Battery Wakeup

This function should be activated only after the installation. In the case of a low battery voltage shutdown, the inverter will shut-down. This setting can be enabled, so when the inverter detects PV or grid it wakes up the battery. This function conflicts with the battery reverse polarity protection( If the installer connects cables with wrong polarity, the inverter can protect itself from damage).To avoid the possible damage during installation, do not active battery wakeup function before finishing the first commissioning.

### 5.5.4 Backup Control

This function is used for set the backup port.

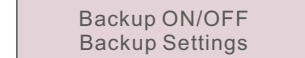

Figure 5.25 Backup control

#### 5.5.4.1 Backup ON/OFF

This switch is to enable or disable the backup port of the inverter.



Figure 5.26 Backup ON/OFF

#### 5.5.4.2 Backup Settings

Set the voltage/frequency of the backup port.  
Enable or disable the voltage droop.

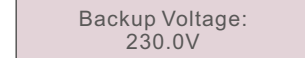

Figure 5.27 Backup settings

### 5.5.5 Storage Energy Set

There are three optional modes:

1. Meter Select
2. Stg Mode Select
3. CT Install

# 5. Operation

## 5.5.5.1 Meter Select

There are 2 options in this setting : 1Ph meter and 3Ph Meter.

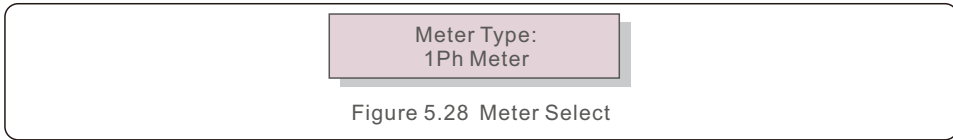

Figure 5.28 Meter Select

## 5.5.5.2 Stg Mode Select

In this section, you can set the "Time charging mode".

User can enable the "Time charging mode" and define the corresponding parameters:

1. Time of Use (Run/Stop)
2. Charge Limit (0~90A)
3. Discharge Limit (0~90A)
4. Charge Time
5. Discharge Time
6. Chg Total Time

The default mode is called "AUTO" mode (which is not shown and can't be selected).

The "AUTO" mode logic is: Store excess PV energy into the battery and then use it to support loads instead of exporting to the grid. (Maximize system self-consumption rate).

To change back to the default mode, simply set all the other modes as OFF.

## 5.5.5.3 CT Install

This setting is to define the position where the CT is installed:

1. Grid
2. PV Inverter

## 5.5.6 STD. Mode Settings

There are 6 setting under STD. Mode settings.

1. Working Mode Set
2. Power Rate Limit
3. Freq. Derate Set
4. 10mins Voltage Set
5. 3Tau Settings
6. Initial Settings



This function is applicable by maintenance personnel only, wrong operation will prevent the inverter from working properly.

# 5. Operation

## 5.5.6.1 Enable logic interface settings

When select G98 or G99 standard to use the logic interface function, please follow below settings to enable the **DRM**. DRM default setting is "OFF", if DRM set "ON", but the logic interface un-connected to the switch or the switch is open, the inverter HMI will display "Limit by DRM" and the inverter output power will be limited to zero.

1. Select **Initial Settings**
2. Select **DRM** and set it "ON"

## 5.5.7 Software Update

There are 2 settings under Software Update.

1. HMI Update
2. DSP Update



This function is applicable by maintenance personnel only, wrong operation will prevent the inverter from working properly.

## 5.5.8 Export Power Set

Select EPM Settings from the Main Menu to access the following options:

1. EPM ON/OFF
2. Backflow Power
3. FailSafe ON/OFF

### 5.5.8.1 EPM ON/OFF

There are 2 settings in this menu as below:

1. ON
2. OFF

### 5.5.8.2 Backflow Power

This submenu is used for set allowed power that inverter can send to grid.

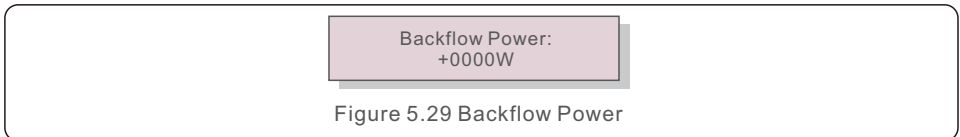

Figure 5.29 Backflow Power

# 5. Operation

## 5.5.8.3 FailSafe ON/OFF

This setting is used to give out an alarm (stop inverter generation as well) when the CT/Meter connection is lost during operation. It can prevent potential backflow power into the grid when the system loses control.



YES=<ENT> NO=<ESC>  
Fail Safe Set:ON

Figure 5.30 Set the Fail Safe ON/OFF

It is only mandatory to turn on this function when the inverter is installed in UK due to the G100 regulation.

For other regions, customers can enable or disable the function as they desire.

### NOTE:



When the failsafe function is ON and CT/Meter is disconnected somehow, the inverter will stop generation and give "Failsafe" alarm on the LCD. When the failsafe function is OFF and CT/Meter is disconnected somehow, the inverter will keep the output power as the last moment when the CT/Meter is still connected. After a restart, the inverter will output at full power without limit.

## 5.5.9 Reset Password

This function is used for set the new password for menu "Advanced info." and "Advanced information" .



YES=<ENT> NO=<ESC>  
Password: 0000

Figure 5.31 Reset password

Enter the right password before set new password. Press the DOWN key to move the cursor. Press the UP key to revise the value. Press the ENTER key to execute the setting. Press the ESC key to return to the previous menu.

# 5. Operation

## 5.5.10 Restart HMI

The function is used for restart the HMI.



This function is applicable by maintenance personnel only, wrong operation will prevent the inverter from working properly.

## 5.5.11 Self Test CEI 0-21

The function is used only for Italy market.

There are 3 setting under Self Test CEI 0-21.

1. Complete Self Test
2. Single ProtectTest
3. Test Report

## 5.5.12 Compensation Set

This function is used to calibrate inverter output energy and voltage. It can compensate for minor power and voltage measurement errors in the inverter measurement circuit.

Two sections are included: Power Parameter and Voltage Parameter.

The screen shows:



→ Power Parameter  
Voltage Parameter

Figure 5.32 Compensation Set



This setting is used for grid operators, do not change this setting unless specifically instructed to.

# 6. Commissioning

## 6.1 Preparation of Commissioning

- Ensure all the devices are accessible for operation, maintenance and service.
- Check and confirm that the inverter is firmly installed.
- Space for ventilation is sufficient for one inverter or multiple inverters.
- Nothing is left on the top of the inverter or battery module.
- Inverter and accessories are correctly connected.
- Cables are routed in safe place or protected against mechanical damage.
- Warning signs and labels are suitably affixed and durable.

## 6.2 Commissioning Procedure

1. Verify the battery voltage and polarity are satisfactory.
2. Turn on the battery switch between inverter and battery.
3. Verify the inverter initializes.
4. Set the grid standard to your local grid requirements.
5. Configure the inverter to your system requirements.

# 7. Maintenance

Solis AC-Coupled inverter does not require any regular maintenance. However, cleaning the heatsink will help inverter dissipating heat and increase the lifetime of inverter. The dirt on the inverter can be cleaned with a soft brush.



**CAUTION:**

Do not touch the surface when the inverter is operating. Some parts may be hot and cause burns. Turn OFF the inverter (refer to Section 6.2) and let it cool down before you do any maintenance or cleaning of inverter.

The LCD and the LED status indicator lights can be cleaned with cloth if they are too dirty to be read.



**Note:**

Never use any solvents, abrasives or corrosive materials to clean the inverter.

# 8. Troubleshooting

The inverter has been designed in accordance with international grid tied standards for safety, and electromagnetic compatibility requirements. Before delivering to the customer the inverter has been subjected to several test to ensure its optimal operation and reliability.

In case of a failure the LCD screen will display an alarm message. In this case the inverter may stop feeding energy into the grid. The alarm descriptions and their corresponding alarm messages are listed in Table 8.1:

| Alarm Message             | Failure description           | Solution   |
|---------------------------|-------------------------------|--|
| OV-G-V                    | Grid Overvoltage              | Check if the grid is correctly connected, wait for the grid to be normal.  |
| UN-G-V                    | Grid Undervoltage             | Check if the grid is correctly connected, wait for the grid to be normal.  |
| OV-G-F                    | Grid Overfrequency            | Check if the grid is correctly connected, wait for the grid to be normal.  |
| UN-G-F                    | Grid Underfrequency           | Check if the grid is correctly connected, wait for the grid to be normal.  |
| NO-Grid                   | No Grid                       | Check if the grid is correctly connected, wait for the grid to be normal.  |
| OV-BUS                    | DC Bus overvoltage            | Restart the inverter, if the fault still exists, contact Solis after-sale service.   |
| UN-BUS                    | DC Bus voltage sampling Error | Restart the inverter, if the fault still exists, contact Solis after-sale service.   |
| DC-INTF.                  | Battery Overcurrent           | Restart the inverter, if the fault still exists, contact Solis after-sale service.   |
| IGFOL-F                   | Grid Current Tracking Error   | Restart the inverter, if the fault still exists, contact Solis after-sale service.   |
| OV-G-I                    | Grid Overcurrent              | Restart the inverter, if the fault still exists, contact Solis after-sale service.   |
| AC Transient over current | AC Transient Overcurrent      | Check if the backup port is shorted, Restart the inverter, if the fault still exists, contact Solis after-sale service.  |
| DCInj-FAULT               | Over DC injection             | Restart the inverter, if the fault still exists, contact Solis after-sale service.   |
| IGBT-OV-I                 | IGBT Overcurrent              | Restart the inverter, if the fault still exists, contact Solis after-sale service.   |
| OV-TEM                    | Internal Over Temperature     | Check if the inverter installation meets the requirements listed in the manual, Restart the inverter, if the fault still exists, contact Solis after-sale service. |
| RelayChk-FAIL             | Relay Fault                   | Restart the inverter, if the fault still exists, contact Solis after-sale service.   |

# 8. Troubleshooting

| Alarm Message | Failure description          | Solution  |
|---------------|------------------------------|---|
| GRID-INTF02   | Grid Interference 02         | Restart the inverter, if the fault still exists, contact Solis after-sale service.  |
| IG-AD         | Grid Current Sampling Error  | Restart the inverter, if the fault still exists, contact Solis after-sale service.  |
| OV-IgTr       | Grid Transient Overcurrent   | Restart the inverter, if the fault still exists, contact Solis after-sale service.  |
| OV-Vbatt-H    | Battery Hardware Overvoltage | Check if the battery is correctly connected or the battery contactor is disconnected, Restart the battery, Restart the inverter, if the fault still exists, contact Solis after-sale service. |
| OV-ILLC       | LLC Hardware Overcurrent     | Restart the inverter, if the fault still exists, contact Solis after-sale service.  |
| OV-Vbatt      | Battery Overvoltage          | Check if the battery overvoltage setting is reasonable, if the battery reaches its end of life.   |
| UN-Vbatt      | Battery Undervoltage         | Check if the battery overvoltage setting is reasonable, if the battery reaches its end of life.   |
| DSP-B-FAULT   | Slave DSP Check Error        | Restart the inverter, if the fault still exists, contact Solis after-sale service.  |
| NO-Battery    | Battery Not Connected        | Check if the battery is correctly connected or the battery contactor is disconnected, Restart the battery.  |
| OV-Vbackup    | Inverting Overvoltage        | Restart the inverter, if the fault still exists, contact Solis after-sale Service.  |
| Over-Load     | Bypass overload fault        | 1. Check the load of Backup port is over rating output power or not.<br>2. Reduce the load of Backup port, then restart inverter.   |
| CT-Fail       | CT Installed Fail            | Check if CT is correctly installed or the cables are broken/loosen .  |
| MET_Comm_FAIL | Meter COM Fail               | Check if the CT/Meter setting is correct or the cables are broken/loosen.   |
| CAN_Comm_FAIL | Battery CAN Fail             | Check if the CAN cable is correctly connected or the cables are broken/loosen.  |
| DSP_Comm_FAIL | DSP COM Fail                 | Restart the inverter, if the fault still exists, contact Solis after-sale service.  |
| Alarm-BMS     | Battery BMS Alarm            | Retart the battery, if fault still exists, please contact battery manufacturer or installer.  |
| BatName-FAIL  | Wrong Battery Model          | Make sure the actual battery model matches the selection on inverter LCD.   |

Table 7.1 Fault message and description

## 8. Troubleshooting



**NOTE:**

If the inverter displays any alarm message as listed in Table 8.1; please turn off the inverter and wait for 5 minutes before restarting it. If the failure persists, please contact your local distributor or the service center.

Please keep ready with you the following information before contacting us.

1. Serial number of Solis Inverter;
2. The distributor/dealer of Solis Inverter (if available);
3. Installation date.
4. The description of problem (i.e. the alarm message displayed on the LCD and the status of the LED status indicator lights. Other readings obtained from the Information submenu (refer to Section 6.2) will also be helpful.);
5. The system configuration.
6. Your contact details.

## 9. Specifications

| Technical Data               | RAI-3K-48ES-5G                                 |
|------------------------------|--|
| <b>Output AC( Grid side)</b> |  |
| Rated output power           | 3000 W   |
| Max. apparent output power   | 3.3 kVA  |
| Operation phase              | 1/N/PE   |
| Rated grid voltage           | 230 V  |
| The grid voltage range       | 184-264 V                                      |
| Rating grid Frequency        | 50 HZ/ 60 Hz                                   |
| AC grid frequency range      | 45-55 Hz/ 55-65 Hz                             |
| Rating grid output current   | 13 A   |
| Max. output current          | 20 A   |
| Power Factor                 | >0.99 (0.8 leading - 0.8 lagging)              |
| THDi                         | <3%  |
| <b>Battery</b>               |  |
| Battery Type                 | Li-ion / Lead-acid                             |
| Battery voltage range        | 40-60 V  |
| Battery capacity             | 50-2000 Ah                                     |
| Maximum charging Power       | 3kW  |
| Max.charge/discharge current | 60 A   |
| Communication                | CAN  |
| <b>Output AC(Back-up)</b>    |  |
| Rated output power           | 3 kW(Requires battery voltage higher than 55V) |
| Max. apparent output power   | 4.5 kVA  |
| Back-up switch time          | <20 ms   |
| Rated output voltage         | 1/N/PE, 230 V                                  |
| Rated frequency              | 50 Hz / 60 Hz                                  |
| Rated output current         | 13 A   |
| THDv (@linear load)          | <3%  |
| <b>Input AC (Grid side)</b>  |  |
| Input voltage range          | 184-264 V                                      |
| Max. input current           | 23 A   |
| Frequency range              | 45-55 Hz/ 55-65 Hz                             |

# 9. Specifications

| Efficiency                                |  |
|---|--|
| Max. battery charge efficiency            | 94.0%  |
| Max. battery discharge efficiency         | 94.5%  |
| Protection                                |  |
| Battery reverse protection                | Yes  |
| Battery over and under voltage protection | Yes  |
| Short circuit protection                  | Yes  |
| Output over current protection            | Yes  |
| Output over voltage protection            | Yes  |
| Temperature protection                    | Yes  |
| Protective class                          | Class I  |
| General data                              |  |
| Dimensions(W*H*D)                         | 405*510*150 mm   |
| Weight                                    | 12.1 kg  |
| Topology                                  | High frequency isolation   |
| Operation temperature range               | -25~+60 °C   |
| Ingress Protection                        | IP65   |
| Noise emission (Typical)                  | <35 dB (A)   |
| Cooling concept                           | Natural convection   |
| Max.operation altitude                    | 2000 m   |
| Safety/EMC standard                       | G98 or G99, VDE-AR-N 4105/VDE V 0124, EN 50549-1, VDE 0126/UTE C 15/VFR:2019, RD 1699/RD 244/ UNE 206006/UNE 206007-1, CEI 0-21, C10/11, NRS 097-2-1, TOR, EIFS 2018.2, IEC 62116, IEC 61727, IEC 60068, IEC 61683, MEA, PEA |
| Grid connection standard                  | IEC 62477, EN 61000-6-2/-3   |
| Features                                  |  |
| DC connection                             | Screw Terminal   |
| AC connection                             | Screw clamp terminal (Max 6 mm <sup>2</sup> )  |
| Display                                   | LCD, 2X20 Z  |
| Communication                             | Rs485, CAN, Optional:Wi-Fi, GPRS   |
| Warranty                                  | 5 years (Extend to 20 years)   |

# 10. Appendix

## 10.1 Special Back-up Connection

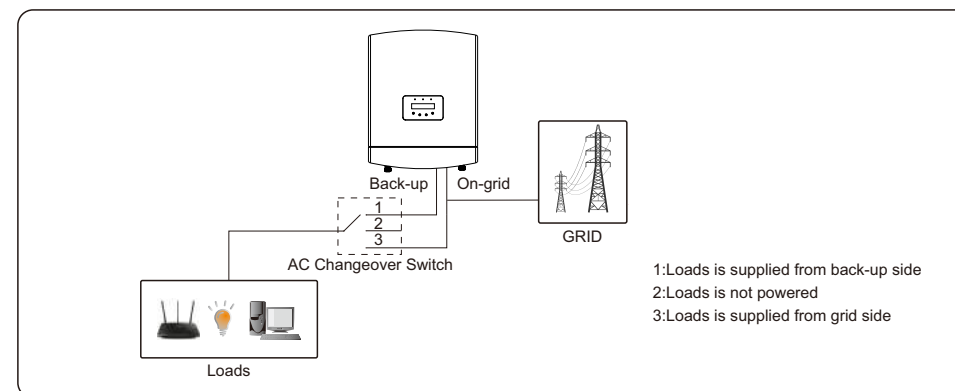

If RAI needs maintenance, then just switch AC Changeover Switch to position 3 as shown above. Thus the loads will be supplied by grid.

AC Changeover Switch is a 3rd party item not supplied by Ginlong.

WiFi

Frequency range: 2.412~2.472GHz

WiFi maximum transmitting power: 18.0dBm

Antenna gain: PCB antenna, gain 2.0dbi

## 10.2 Grid standard selection guide



**NOTE:**

Please check if the grid code setting comply with local requirement.

For different countries and regions, corresponding grid code needs to be selected in the inverter LCD to meet the requirements of local network provider.

This instruction indicates how to change the grid code and what code should be selected in different places.

This following list illustrates the grid standard options in the inverter which are subject to change. It is for your reference only. If customer has any doubts or uncertainty, please consult Solis service department for confirmation.

To set the correct grid code, please enter the following path:

Advanced Settings -> Password:0010 -> Select Standard

Detailed protection limits can be viewed when choosing the code.

Please select "Save&Send" to enforce the code.

# 10. Appendix

---

| NO. | Code in LCD             | Country/Region | Comments   |
|-----|-------------------------|----------------|--|
| 1   | VDE4015                 | Germany        | For German Low Voltage Grid.   |
| 2   | EN50549 PO              | Poland         | For Polish Low Voltage Grid  |
| 3   | EN50549 NL              | Netherland     | For Dutch Low Voltage Grid   |
| 4   | EN50438 L               | -              | General EN50438 Requirement.<br>Possible to be used in Austria, Cyprus, Finland,<br>Czech Republic, Slovenia, etc. |
| 5   | EIFS- SW                | Sweden         | For Swedish Low Voltage Grid   |
| 6   | France                  | France         | For French Low Voltage Grid  |
| 7   | C10/11                  | Belgium        | For Belgian Low Voltage Grid   |
| 8   | NRS097                  | South Africa   | For South African Low Voltage Grid   |
| 9   | CEI0-21                 | Italy          | For Italian Low Voltage Grid   |
| 10  | EN50549L<br>(EN50549-1) | -              | General EN50549-1 requirement which meets<br>local requirements of most European countries                         |
| 11  | G98                     | UK             | For UK Low Voltage Grid <16A   |
| 12  | G99                     | UK             | For UK Low Voltage Grid >16A   |
| 13  | G98 NI                  | North Ireland  | For North Ireland Low Voltage Grid <16A  |
| 14  | G99 NI                  | North Ireland  | For North Ireland Low Voltage Grid >16A  |
| 15  | User-define             | -              | Customized Protection Limits   |
| 16  | Gen50                   | -              | Generator Connected, Frequency-Derating, 50Hz  |
| 17  | Gen 60                  | -              | Generator Connected, Frequency-Derating, 60Hz  |
| 18  | DK1                     | East Denmark   | For East Danish low voltage grid   |
| 19  | DK2                     | West Denmark   | For West Danish low voltage grid   |
| 20  | 50438IE                 | Ireland        | For Irish low voltage grid   |
| 21  | RD1699                  | Spain          | For Spanish low voltage grid   |
| 22  | EN50549 L               | -              | General EN50549 Requirement.<br>Possible to be used in Cyprus, Finland,<br>Czech Republic, Slovenia, Jamaica       |