



DS250E-48DC



- 1-pole surge protector 48 Vdc
- Type 1 and Type 2 application
- I_n 25 kA / I_{max} 70 kA
- Remote signaling
- I_{imp} 25 kA
- IEC 61643-11 and EN61643-11 compliance

Electrical Characteristics		
SPD type <i>following IEC test</i>		1+2
Network		48 Vdc
Nominal line voltage	U_n	48 Vdc
Nominal DC voltage	U_n-dc	48 Vdc
Max. DC operating voltage	U_c	75 Vdc
Operating current <i>Continuous current at U_c</i>	I_c	< 0.1 mA
Follow current	I_f	None
Nominal discharge current <i>15 x 8/20 μs impulses</i>	I_n	25 kA
Max. discharge current <i>max. withstand @ 8/20 μs by pole</i>	I_{max}	70 kA
Total Maximal discharge current <i>max. total withstand @ 8/20 μs</i>	I_{max} Total	140 kA
Impulse current by pole <i>max. withstand 10/350 μs by pole</i>	I_{imp}	25 kA
Connection mode(s)		+/PE or -/PE
Protection mode(s)		Common mode
Protection level <i>@ I_n (8/20 μs)</i>	U_p	0.5 kV
Specific energy by pole <i>max. withstand 10/350 μs</i>	W/R	156 kJ/ohm
Internal Thermal protection		Yes

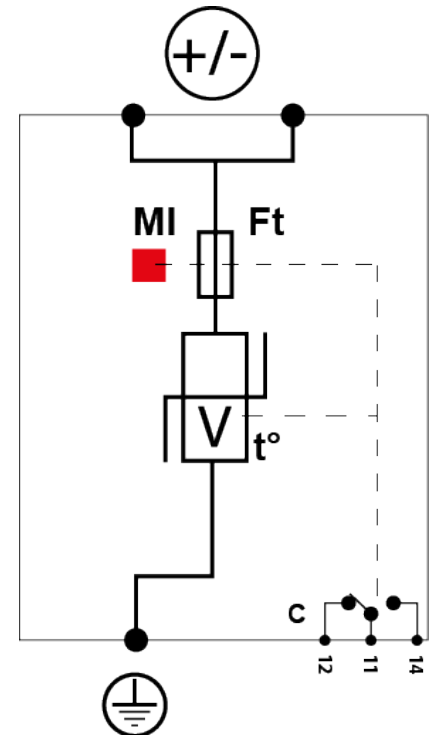
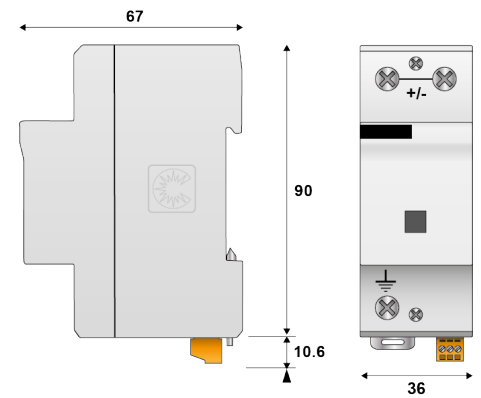



Mechanical Characteristics	
Technology	MOV
SPD configuration	1-pole
Connection to Network	By screw terminals : 6-35 mm ² / by bus
Format	1-pole modular box
Mounting	Symmetrical rail 35 mm (EN60715)
Housing material	Thermoplastic UL94-V0
Operating temperature	-40/+85°C
Protection rating	IP20
Failsafe behavior	Disconnection
Disconnection indicator	1 mechanical indicator
Remote signaling of disconnection	Output on changeover contact
Dimensions	See diagram

V: High-energy varistor
Ft: Thermal fuse
C: Remote signal contact
t°: Thermal disconnection system
MI: Disconnection indicator



Disconnectors		
Thermal disconnecter		Internal
Fuses		Fuses type gG - 315 A



Standards		
Standards compliance		IEC 61643-11 / EN 61643-11 / UL1449 4ed.
Certification		EAC
Part Number		63909



CITEL

N150401a

INSTALLATION INSTRUCTIONS - NOTICE D'INSTALLATION
NOTICIA DE INSTALACIÓN - INSTALLATIONSHINWEISE
ISTRUZIONI PER L'INSTALLAZIONE
INSTRUCOES DE INSTALACAO - MONTÁŽNÍ NÁVOD
РУКОВОДСТВО ПО МОНТАЖУ - 安装指导书

DC surge protector - Parafoudre DC
Überspannungsschutz für DC - DC contra sobretensiones
Protezione DC - Proteção DC - Svodiče přepětí pro DC
Устройство защиты от импульсных перенапряжений для сетей DC - 直流浪涌保护器

Technical Data

 2000 m max. 6500 ft max. -40/+85°C max. -40/+185°F max. indoor use only IP20	P/N	
	DS250E-48DC	DS252C-48DC/G
Network		
48 Vdc	●	
Characteristics		
Uc	75 Vdc	
Ports	1-pole	2-pole
I _{pe}	> 0.1 mA	None

Table 1

Application example

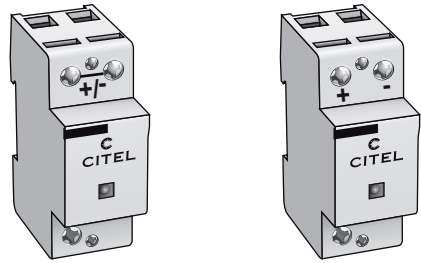
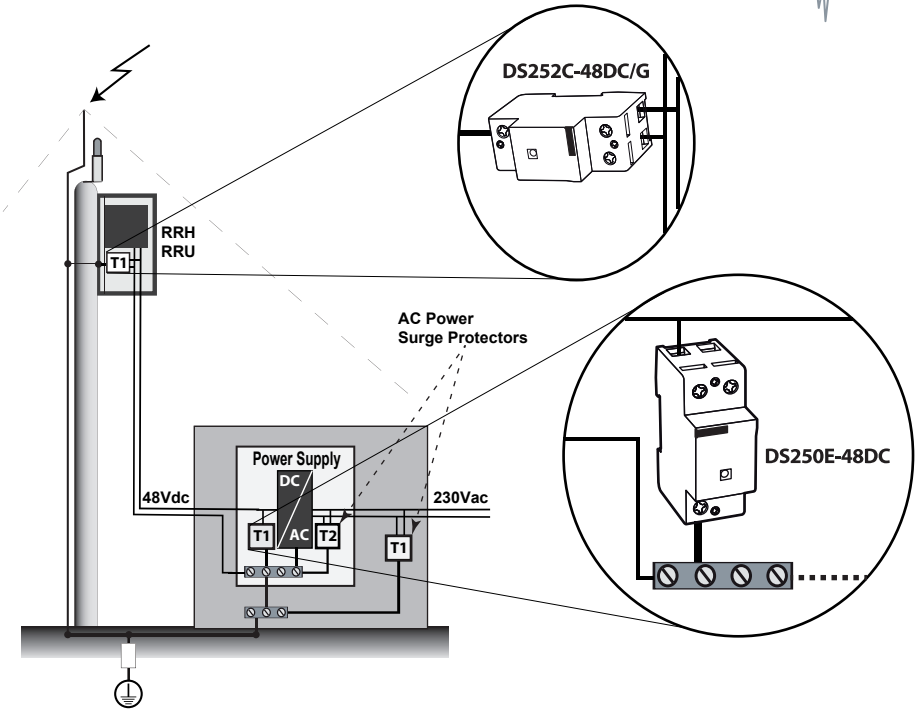

DS250E-48DC

DS252C-48DC/G

Installation

min-max	Ø
	6 - 50 mm ² 11 - 3 AWG
	6 - 35 mm ² 9 - 3 AWG

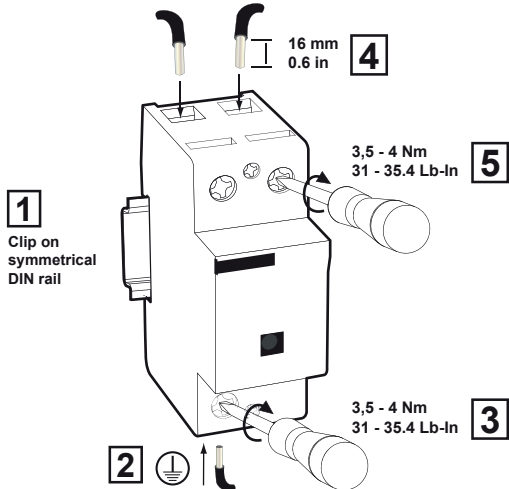

Wiring

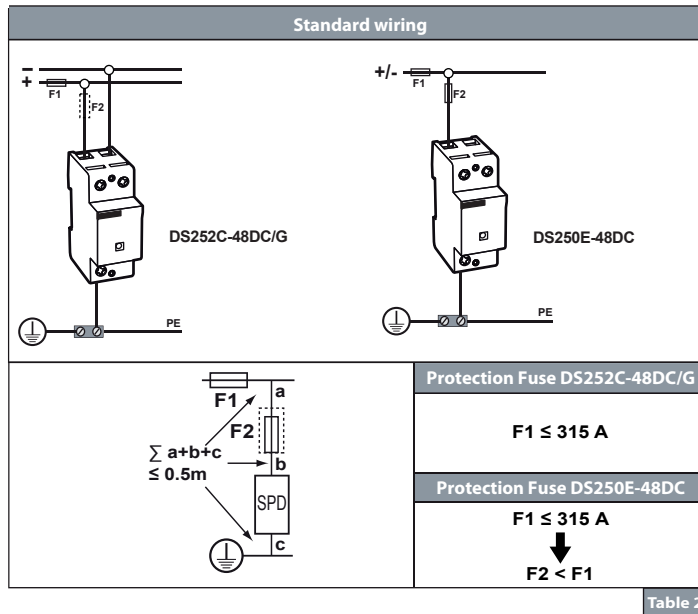

Maintenance

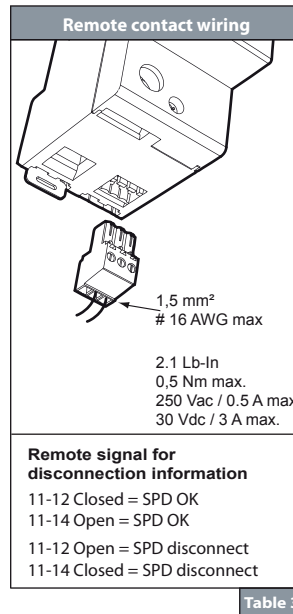
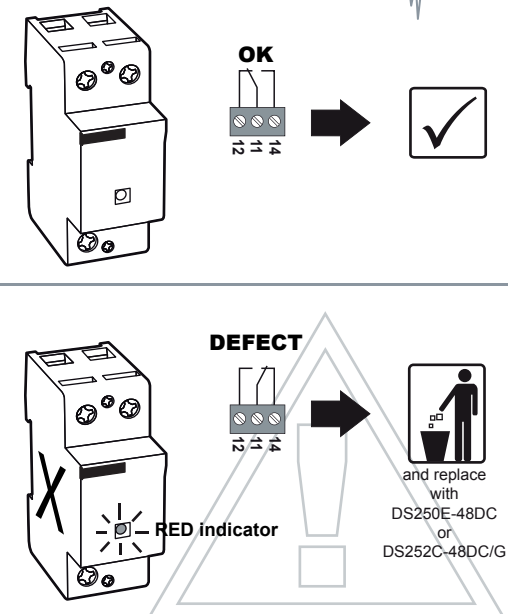



CITEL

SAFETY INSTRUCTIONS
 CONSIGNES DE SECURITE
 SICHERHEITSHINWEISE
 ADVERTENCIA DE SEGURIDAD
 AVVERTENZE IMPORTANTI
 AVISOS IMPORTANTES
 МЕРЫ БЕЗОПАСНОСТИ
 BEZPEČNOSTNÍ POKYNY

安全須知



*This document could be modified without notice.
Updated Information on Website.*

*Ce document peut être modifié sans préavis.
Informations à jour sur site web.*

*Änderungen am Dokument ohne Ankündigung möglich.
Aktuelle Informationen finden Sie auf unserer Webseite.*

*Este documento puede ser modificado sin previo aviso.
Información actualizada en el sitio web.*

*Questo documento può essere modificato senza preavviso.
Informazioni attualizzate disponibile sul sito web.*

*Este documento pode ser modificado sem aviso prévio.
Informação atualizada no website.*

*В документ могут вноситься изменения.
Актуальную информацию смотрите на нашей
WEB-странице.*

*Změny v tomto dokumentu jsou možné bez předchozího
upozornění.*

Aktuální informace najdete na naší webové stránce.

*本文件的修改恕不另行通知。
查看最新文件请登陆公司网站。*

www.citel2cp.com
www.citel.de
www.citel.us
www.citel.com.cn
www.citel.ru
www.citel.cz



ATTENTION !

GB

- Installation must be performed only by electrically skilled operator.
- National electrical installation rules must be followed.
- The unit must be used only as surge protector and according the conditions described in this document.
- Surge protectors must be selected in relation with the maximum DC voltage of the installation (see Table 1)
- Depending of the short-circuit current of the network, dedicated fuses could be installed in the surge protector branch (see Table 2).
- In case of red indicator, the surge protector must be replaced.



ATENCIÓN !

ES

- Solo un operador eléctrico capacitado puede realizar la instalación.
- Las reglas generales nacionales de instalación eléctrica deben ser respetadas.
- El producto solo tiene un uso de protección contra sobretensiones transitorias y debe ser utilizado en las condiciones mencionadas en este documento.
- Las protecciones contra sobretensiones transitorias se usan en relación con una red de baja tensión determinada (ver tabla 1).
- Fusibles dedicados deben ser instalados aguas arriba de la protección, en la conexión en paralelo (ver tabla 2).
- Se debe sustituir la protección cuando el indicador esta puesto en rojo.



ВНИМАНИЕ!

RUS

- монтаж и подключение изделия должны производиться только специалистами-электриками.
- необходимо учитывать требования местных норм и стандартов.
- изделие может использоваться только для защиты от импульсных перенапряжений в соответствии с настоящей инструкцией.
- параметры сети DC должны соответствовать характеристикам изделия (см. таблицу 1).
- обязательна установка токовых предохранителей соответствующего номинала (таблица 2).
- при обнаружении индикатора состояния красного цвета изделие должно быть заменено.



ATTENTION !

FR

- L'installation ne doit être effectuée que par un opérateur électricien dûment qualifié.
- Les règles générales d'installation électrique nationales doivent être respectées.
- Le produit est uniquement destiné à un usage parafoudre et doit être utilisé dans les conditions décrites dans ce document.
- Les parafoudres doivent être sélectionnés en fonction de la tension max. DC de l'installation (voir Table 1).
- En fonction du courant de court-circuit de la ligne, des fusibles dédiés peuvent être installés dans les branches du parafoudre (voir Table 2).
- En cas d'indicateur passant au rouge, le parafoudre doit être remplacé.



ATTENZIONE !

IT

- L'installazione deve essere fatta solamente da elettricisti qualificati.
- Devono essere rispettate le regolamentazioni nazionali e locali riguardanti l'installazione di apparati elettrici.
- L'unità deve essere usata solo come protezione da sovratensioni e secondo le condizioni descritte in questo documento.
- Le protezioni da sovratensione devono essere scelte in funzione della corrente alternata di rete (vedere la tabella 1).
- Fusibili dedicati devono essere installati nel ramo protetto da sovratensione (vedere la tabella 2).
- Nel caso in cui si accenda l'indicatore rosso, l'unità di protezione da sovratensione deve essere sostituita.



VAROVÁNÍ

CZ

- Montáž a připojení svodiče přepětí smí provádět pouze pracovník s příslušnou elektrotechnickou kvalifikací.
- Je zapotřebí dodržovat zásady bezpečnosti práce i platné národní elektrotechnické předpisy.
- Svodič přepětí se smí používat pouze v souladu se svými technickými parametry a podle těchto montážních pokynů.
- Svodiče přepětí musí být zvoleny podle maximálního stejnosměrného napětí fotovoltaické aplikace (při záporných teplotách - viz tabulka 1).
- Podle hodnoty zkratového proudu fotovoltaického zdroje může být zapotřebí instalovat speciální pojistky v obvodu svodiče přepětí (viz tabulka 2).
- Pokud signalizace stavu svodiče má ČERVENOU barvu, pak svodič/modul je VADNÝ a musí být vyměněn.



WARNING !

D

- Die Montage und der Anschluss des Gerätes dürfen nur durch eine Elektrofachkraft durchgeführt werden.
- Nationale Installations Vorschriften sind zu beachten.
- Das Gerät ist nur im Rahmen dieser Installationshilfe und seiner technischen Daten zu verwenden.
- Die Ableiter sind nach der max. Spannung auszuwählen (siehe Tabelle 1).
- Die Versicherungen sind nach der Tabelle 2 zu selektieren und zu installieren.
- Ist die Anzeige im Sichtfenster auf ROT umgeschaltet, so ist das Modul DEFEKT und muss ausgetauscht werden.



AVISO !

PT

- A instalação deve ser feita por um electricista habilitado.
- Devem ser seguidas todas as regras de segurança indicadas pelo operador eléctrico.
- Esta protecção deve ser utilizada apenas como protecção contra sobretensões e de acordo com as condições mencionadas neste documento.
- A protecção deve ser escolhida de acordo com a rede eléctrica AC (ver quadro 1).
- Devem ser instalados fúsisveis de protecção a montante da protecção (ver quadro 2).
- Caso o indicador vermelho esteja activo, dever-se-á substituir a protecção.



安全須知!

中文

- 产品安装只能由具备专业资质的人员实施；
- 请遵守国家电气安装相关规范；
- 本产品仅作为电涌保护器且在本文件所规定的条件下使用；
- 请根据光伏装置的最大直流电压选用电涌保护器，参见Table 1；
- 可根据光伏装置的短路电流在电涌保护器前端安装适当的熔断器，参见Table 2；
- 当状态指示变为红色时，须及时更换电涌保护器；