



POWER – SIMPLY SAVE

3in1

- Energy management (according to DIN EN ISO 50001)
 - Power quality monitoring and analysis
 - Residual current monitoring (RCM)

Janitza®



UMG 96RM – Multifunction power analyser

- Communication (device-specific)**
- Modbus (RTU)
 - Profibus DP V0
 - Profinet
 - TCP/IP
 - M-Bus

- Interfaces**
- RS485 (UMG 96RM, UMG 96RM-P, UMG 96RM-CBM)
 - Profibus (UMG 96RM-P)
 - Profinet (UMG 96RM-PN)
 - M-Bus (UMG 96RM-M)
 - Ethernet (UMG 96RM-EL)
 - USB (UMG 96RM-P, UMG 96RM-CBM)

- Accuracy of measurement**
- Energy: Class 0.5S (... / 5 A)
 - Current: 0.2 %
 - Voltage: 0.2 %

- Power quality**
- Harmonics up to 40th harmonic
 - Rotary field components
 - Distortion factor THD-U / THD-I
 - Waveform display (UMG 96RM-EL) via GridVis®-Basic software

- Networks**
- TN, TT, IT networks
 - 3 and 4-phase networks
 - Up to 4 single-phase networks

- Measured data memory (UMG 96RM-CBM, UMG 96RM-P)**
(UMG 96RM, UMG 96RM-M und UMG 96RM-EL without measurement data memory, energy, minimum and maximum values will be saved in the EEPROM)
- 256 MB Flash

- Up to 4 digital inputs**
- Pulse input
 - Logic input
 - State monitoring

- Up to 6 digital outputs**
- Pulse output kWh / kvarh
 - Switch output
 - Threshold value output
 - Logic output
 - Remote via Modbus / Profibus

- Network visualisation software**
- GridVis®-Basic (in the scope of supply)



Areas of application



- Measurement, monitoring and checking of electrical characteristics in energy distribution systems
- Recording of load profiles for energy management systems (e.g. ISO 50001)
- Acquisition of the energy consumption for cost centre analysis
- Measured value transducer for building management systems or PLC (Modbus)

Main features

Particular advantages

- Compact construction saves space and costs during installation
- Seamless and sustained recording thanks to large measured data memory or via the online data acquisition (e.g. GridVis®-Service)
- High data security and redundancy
- Comprehensive communications options and protocols
- Multifaceted, pre-defined reports for power quality and energy consumption analysis (via GridVis®-Service)
- Simple report generation at the press of a button or automatically in accordance with defined time plans
- Precision measurement results provide an effective infrastructure as well as high production availability
- Generic Modbus profile: Arbitrary Modbus-capable devices and systems from other manufacturers can be incorporated and visualised in the monitoring solutions
- Long-term availability of the measurement devices guarantees simple retrofitting with system expansions

Energy data acquisition & load profile

- Detailed acquisition of the energy data and the load profile
- More transparency in energy supply through energy analyses
- Safer design of the power distribution systems

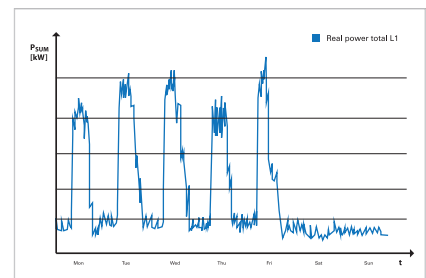

Fig.: Load profiles are the basis for energy management

Cost centre analysis

- Determination of energy costs
- Breakdown and allocation of energy consumers

Energy management systems (ISO 50001)

- Continuous increase in energy efficiency
- Cost reduction
- UMG 96RM series multifunctional power analysers are an important part of energy management systems

Transparency of energy supply

- More transparency through a multi-stage, scalable measurement system
- Acquisition of individual events through continuous measurement with high resolution

	January	February	March	April	December	Total
HKA Water	2480	1240	160	380	240	4500 €
Boiler Heating	12 kWh	6 kWh	0,8 kWh	1,9 kWh	1,2 kWh	25,9 kWh
HKA Water	737	386	790	506	454	2873 €
Total	3,27 m ³	1,9 m ³	3,0 m ³	2,5 m ³	2,3 m ³	13,3 m ³
Hall 1	166	155	183	124	171	849 €
Final assembly	831 kWh	776 kWh	920 kWh	871 kWh	856 kWh	4254 kWh
Hall 2	155	171	166	195	191	878 €
Painting	776 kWh	856 kWh	831 kWh	980 kWh	956 kWh	4399 kWh
Total	3538 €	1952 €	1299 €	1255 €	1056 €	9100 €

Fig.: Cost centre analysis

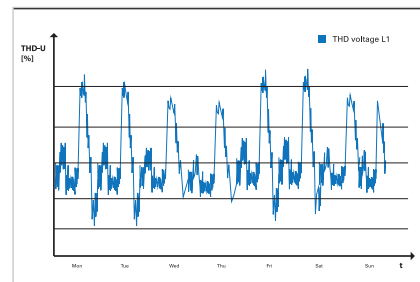

Fig.: Transparency of energy supply



Power quality monitoring

- Notification of inadequate power quality
- Introduction of measures to address network problems
- Prevention of production downtimes
- Significantly longer service life for equipment
- Improved sustainability

0,5 kWh
Class

Measurement accuracy of 0.2 % (V), kWh class = 0.5S

- High sampling rate at 21.3 kHz
- Reliable measurement accuracy of 0.2 % (V)
- Effective energy class (kWh): 0.5S

8
Tariffs

Energy meter with 8 tariffs, effective and reactive energy

- Energy measurement in 4 quadrants, each with 8 tariffs for effective and reactive energy
- Safe and precise acquisition of operational values for individual electrical loads



Communications options:

Ethernet, Profibus, Modbus, M-Bus, ...

- Numerous interfaces and protocols, guaranteeing an easy system connection (energy management system, PLC, SCADA, BMS)

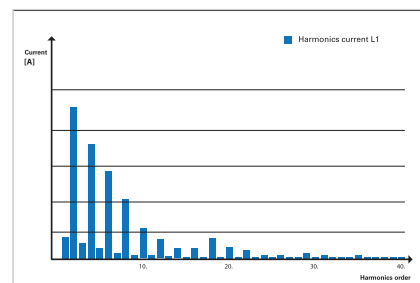

Fig.: Power quality monitoring
(Harmonics analysis for the current up to 40th order harmonics)



Large measurement data memory

- Saving of measurement data possible over very long periods of time
- Recording freely user configurable



Harmonics analyser

- Harmonics analysis up to 40th harmonic
- Information about power quality, grid disturbances and possible "network polluters"

Pluggable screw terminals

- Convenient installation even where spaces are tight

Backlight

- Large, high-contrast LCD display with backlighting
- Very good readability and intuitive operation, even in poor lighting conditions

Basic device

- RS485 interface with Modbus protocol and 2 digital outputs enable quick and low-cost monitoring of power quality and energy consumption

Profibus and digital IOs

- The Profibus connection is used in systems where the UMG 96RM-P is to be incorporated into the automation environment (PLC controllers)



M-Bus

- The UMG 96RM-M can be simply and cost-effectively integrated into consumption data acquisition systems via the M-Bus connection.
- The M-Bus is primarily used for the acquisition of consumption data collection from various different consumption meters, such as water, gas, heat or electrical current.

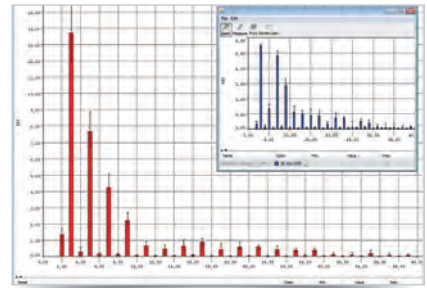

Fig.: GridVis® software: Harmonics analysis



Fig.: Pluggable screw terminals for easy connection



Fig.: LCD Display backlight



Ethernet (TCP/IP) with the UMG 96RM-EL

- Simple integration into the Ethernet (LAN) network
- Fast and reliable data communication

4th current transformer input

- Continuous monitoring of the N-conductor by means of the 4th current input
- Available with variants UMG 96RM-P and UMG 96RM-CBM



Dimension diagrams

All dimensions in mm

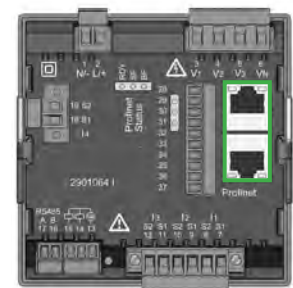
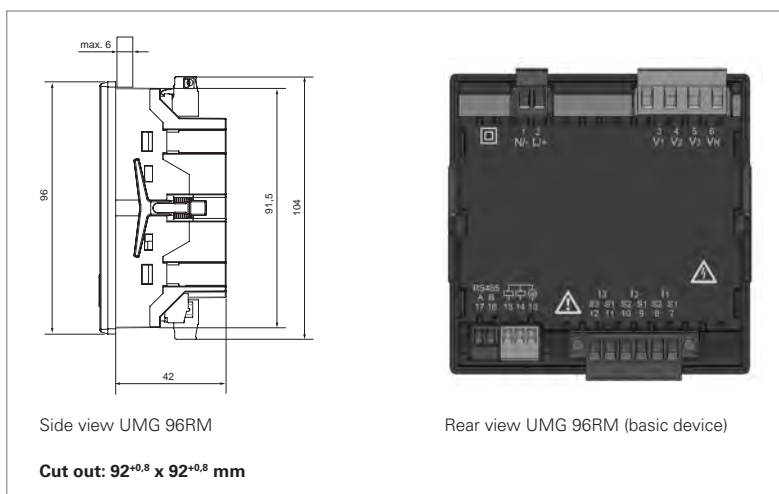

Rear view UMG 96RM-PN
Profinet variant

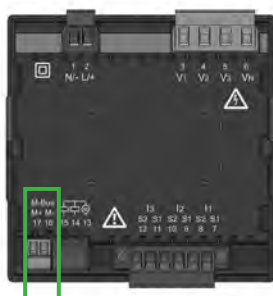

Rear view 96RM-M
M-Bus variant

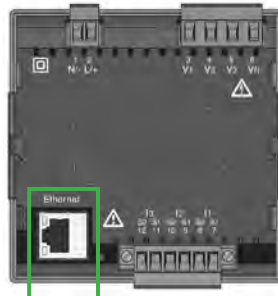

Rear view 96RM-EL
Ethernet light variant

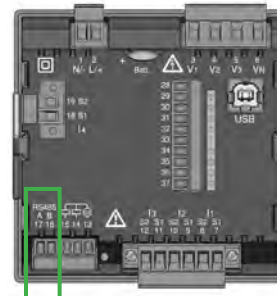

Rear view 96RM-CBM
Modbus variant

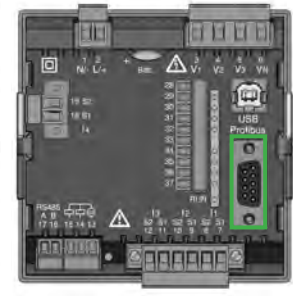

Rear view 96RM-P
Profibus variant

The illustrations shown here are examples. Further dimensional drawings and connection diagrams are available on request or can be viewed on our homepage.



Typical connection

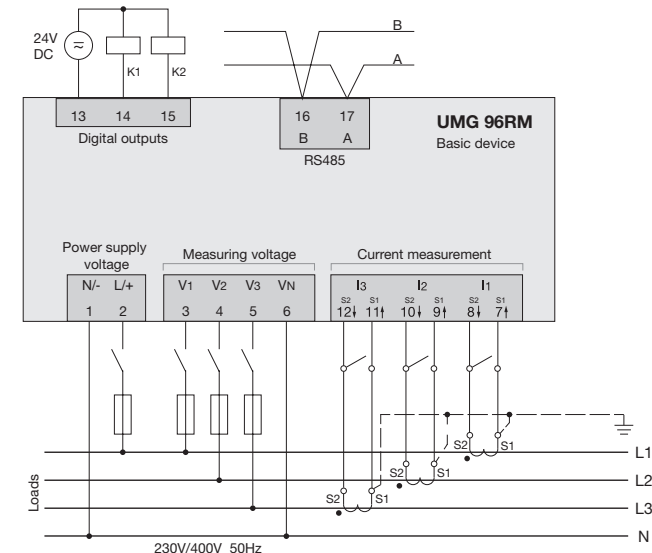

Connection variant UMG 96RM

The illustration shown here is an example. Further connection diagrams are available on request or can be viewed on our homepage.



Device overview and technical data

	UMG 96RM ^{*1}	UMG 96RM-M ^{*1}	UMG 96RM-EL ^{*1}	UMG 96RM-CBM ^{*1}	UMG 96RM-P ^{*1}	UMG 96RM-PN ^{*1}
Item no. (90–277 V AC/90–250 V DC)	52.22.061	52.22.069	52.22.068	52.22.066	52.22.064	52.22.090
Item no. (24–90 V AC/24–90 V DC)	52.22.070	52.22.073	52.22.072	52.22.067	52.22.065	52.22.091
Interfaces	RS485	M-Bus	Ethernet	RS485, USB	RS485, Profibus, USB	RS485, Ethernet, Profinet
Protocols						
Modbus RTU	•	-	-	•	•	•
Modbus TCP	-	-	•	-	-	•
Profibus DP V0	-	-	-	-	•	-
Profinet	-	-	-	-	-	•
M-Bus	-	•	-	-	-	-
DHCP oder DCP	-	-	•	-	-	•
ICMP (Ping)	-	-	•	-	-	•
Measured data recording						
Current measurement channel	3	3	3	4	4	4 (+2)
Memory (Flash)	-	-	-	256 MB	256 MB	-
Battery	-	-	-	Type CR2032 3 V, Li-Mn	Type CR2032 3 V, Li-Mn	-
Clock	-	-	-	•	•	-
Digital inputs and outputs						
Digital inputs	-	-	-	4	4	3 ^{*3}
Digital outputs (as switch or pulse output)	2	2	-	6	6	2 (+3) ^{*3}
Mechanical properties						
Device dimensions in mm (H x W x D) ^{*2}	96 x 96 x approx. 48	96 x 96 x approx. 48	96 x 96 x approx. 48	96 x 96 x approx. 78	96 x 96 x approx. 78	96 x 96 x approx. 78

Comment: For detailed technical information please refer to the operation manual and the Modbus address list.

• = included - = not included

*1 Inclusive UL certification.

*2 Accurate device dimensions can be found in the operation manual.

*3 Optionally 3 digital inputs or outputs (no pulse output)

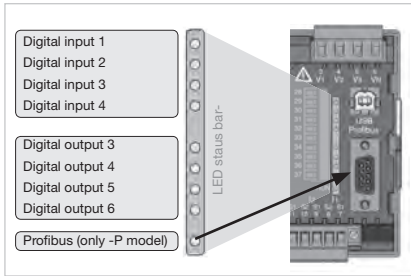

Fig.: LED status bar for the inputs and outputs (UMG 96RM-CBM and UMG 96RM-P)



Fig.: UMG 96RM-PN with Profinet interface



Fig.: Battery insertion on the rear (UMG 96RM-CBM and UMG 96RM-P)

General	
Use in low and medium voltage networks	•
Accuracy voltage measurement	0.2 %
Accuracy current measurement	0.2 %
Accuracy active energy (kWh, .../5 A)	Class 0.5S
Number of measurement points per period	426
Uninterrupted measurement	•
RMS - momentary value	
Current, voltage, frequency	•
Active, reactive and apparent power / total and per phase	•
Power factor / total and per phase	•
Energy measurement	
Active, reactive and apparent energy [L1,L2,L3, Σ L1-L3]	•
Number of tariffs	14
Recording of the mean values	
Voltage, current / actual and maximum	•
Active, reactive and apparent power / actual and maximum	•
Frequency / actual and maximum	•
Demand calculation mode (bi-metallic function) / thermal	•
Other measurements	
Operating hours measurement	•
Power quality measurements	
Harmonics per order / current and voltage	1st – 40th
Distortion factor THD-U in %	•
Distortion factor THD-I in %	•
Rotary field indication	•
Current and voltage, positive, zero and negative sequence component	•
Measured data recording	
Average, minimum, maximum values	•
Alarm messages	•
Time stamp	•
Time basis average value	freely user-defined
RMS averaging, arithmetic	•
Displays and inputs / outputs	
LCD display (with backlighting), 2 buttons	•
Voltage inputs	L1, L2, L3 + N
Password protection	•
Software GridVis®-Basic**	
Online and historic graphs	•
Databases (Janitza DB, Derby DB); MySQL, MS SQL with higher GridVis® versions)	•
Manual reports (energy, power quality)	•
Topology views	•
Manual read-out of the measuring devices	•
Graph sets	•
Programming / threshold values / alarm management	
Comparator (2 Groups with 3 comparators each)	•
Technical data	
Type of measurement	Constant true RMS Up to 40th harmonic
Nominal voltage, three-phase, 4-conductor (L-N, L-L)	277 / 480 V AC
Nominal voltage, three-phase, 3-conductor (L-L)	480 V AC
Measurement in quadrants	4
Networks	TN, TT, IT

Comment:

For detailed technical information please refer to the operation manual and the Modbus address list.

• = included - = not included

** Optional additional functions with the packages GridVis®-Professional, GridVis®-Service and GridVis®-Ultimate.

Measured voltage input	
Overvoltage category	300 V CAT III
Measured range, voltage L-N, AC (without potential transformer)	10 ... 300 Vrms
Measured range, voltage L-L, AC (without potential transformer)	18 ... 520 Vrms
Resolution	0.01 V
Impedance	4 MOhm / phase
Frequency measuring range	45 ... 65 Hz
Power consumption	approx. 0.1 VA
Sampling frequency per channel (50 / 60 Hz)	21.33 / 25.6 kHz
Measured current input	
Rated current	1 / 5 A
Resolution	0.1 mA
Measurement range	0.001 ... 6 Amps
Overvoltage category	300 V CAT II
Measurement surge voltage	2 kV
Power consumption	approx. 0.2 VA (Ri = 5 mOhm)
Overload for 1 sec.	120 A (sinusoidal)
Sampling frequency per channel (50 / 60 Hz)	21.33 / 25.6 kHz
Digital inputs and outputs	
Digital inputs*5	
Maximum counting frequency	20 Hz
Input signal present	18 ... 28 V DC (typical 4 mA)
Input signal not present	0 ... 5 V DC, current < 0.5 mA
Digital outputs*6	
Switching voltage	max. 60 V DC, 33 V AC
Switching current	max. 50 mA Eff AC / DC
Response time	10 / 12 periods + 10 ms
Pulse output (energy pulse)	max. 50 Hz
Maximum cable length	up to 30 m unshielded, from 30 m shielded
Mechanical properties	
Weight	approx. 0.3 kg
Protection class per EN 60529	Front: IP40; Back: IP20
Assembly per IEC EN 60999-1 / DIN EN 50022	Front panel installation
Cable cross section	
Supply voltage	0.2 to 2.5 mm ²
Current measurement	0.2 to 2.5 mm ²
Voltage measurement	0.08 to 4.0 mm ²
Environmental conditions	
Temperature range	Operation: K55 (-25 ... +70 °C)
Relative humidity	Operation: 0 to 90 % RH
Operating height	0 ... 2000 m above sea level
Degree of pollution	2
Installation position	user-defined
Electromagnetic compatibility	
Electromagnetic compatibility of electrical equipment	Directive 2004/108/EC
Electrical equipment for use within certain voltage limits	Directive 2006/95/EC
Equipment safety	
Safety requirements for electrical equipment for measurement, regulation, control and laboratory use – Part 1: General requirements	IEC/EN 61010-1
Part 2-030: Particular requirements for testing and measuring circuits	IEC/EN 61010-2-030
Noise immunity	
Class A: Industrial environment*7	IEC/EN 61326-1
Electrostatic discharge	IEC/EN 61000-4-2
Voltage dips	IEC/EN 61000-4-11
Emissions	
Class B: Residential environment	IEC/EN 61326-1
Radio disturbance voltage strength 30 – 1000 MHz	IEC/CISPR11/EN 55011
Radiated interference voltage 0.15 – 30 MHz	IEC/CISPR11/EN 55011
Firmware	
Firmware update	Update via GridVis® software. Firmware download (free of charge) from the website: http://www.janitza.com/downloads

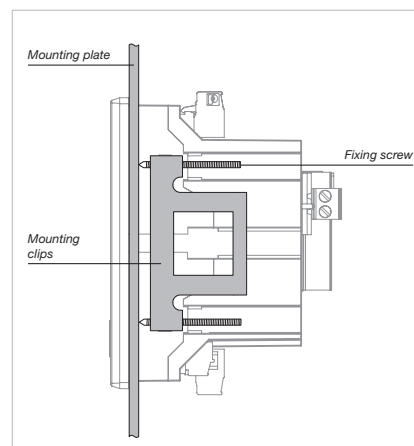

Fig.: The fastening into a switchboard is implemented via the side-mounted fastening clamps (UMG 96RM-P / UMG 96RM-CBM)

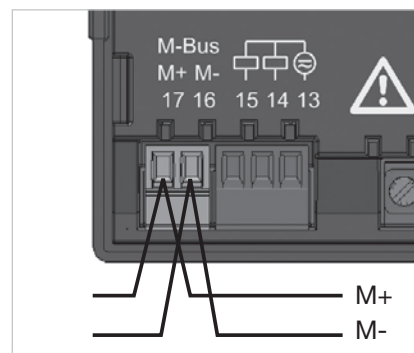

Fig.: M-Bus interface with 2-pole plug contact



Fig.: 2-pole plug contact with cable connection (cable type: 2 x 0.75 mm²) via twin core end sheathes

Comment: For detailed technical information please refer to the operation manual and the Modbus address list

• = included - = not included

*5 The information relates exclusively to the measurement devices UMG 96RM-CBM, UMG 96RM-P and UMG 96RM-PN.

*6 The information relates exclusively to the measurement devices UMG 96RM, UMG 96RM-M, UMG 96RM-CBM, UMG 96RM-P and UMG 96RM-PN.

*7 UMG 96RM-PN exclusive Class A: Industrial environment



UMG 96RM-E – Power analyser with Ethernet and RCM

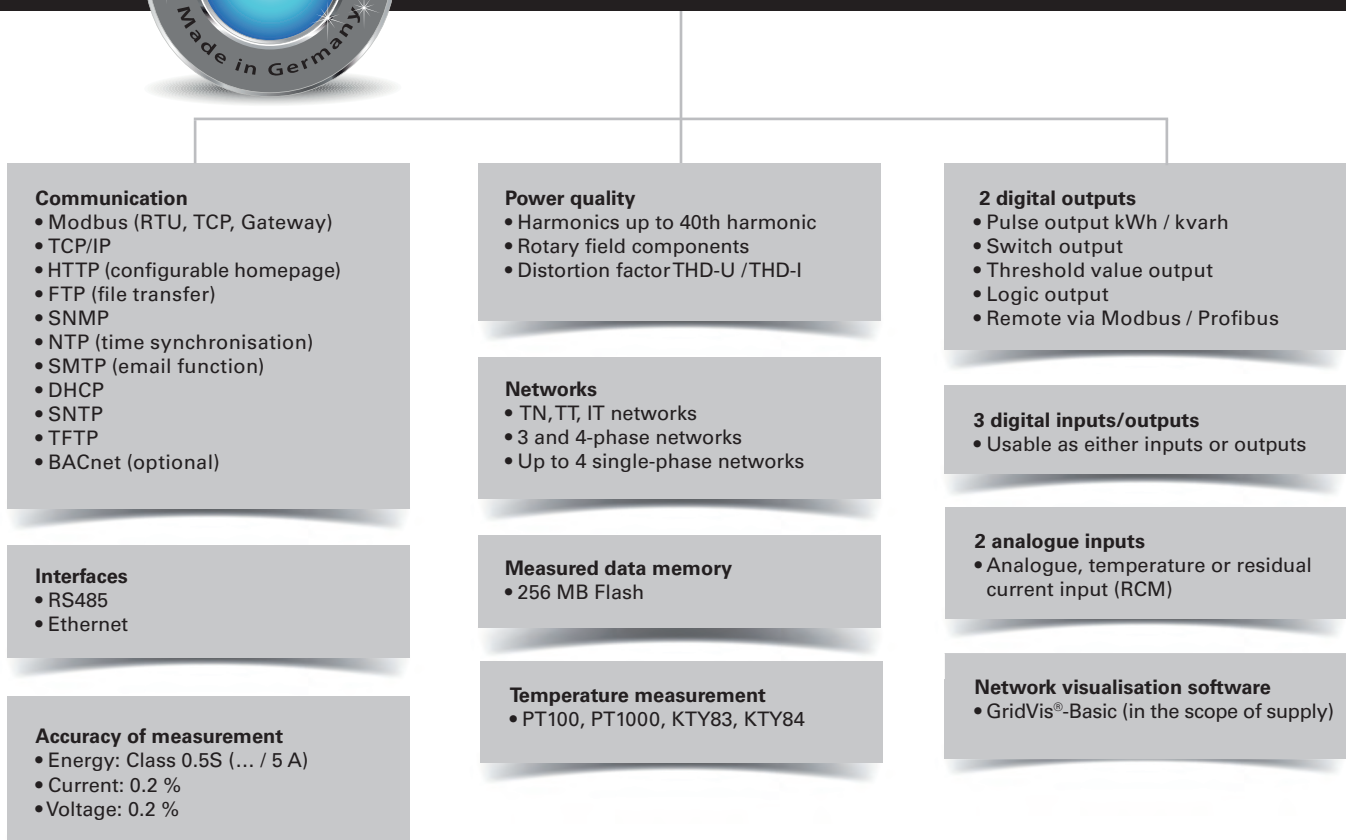

Areas of application



- Measurement, monitoring and checking of electrical characteristics in energy distribution systems
- Recording of load profiles in energy management systems (e.g. ISO 50001)
- Acquisition of the energy consumption for cost centre analysis
- Measured value transducer for building management systems or PLC (Modbus)
- Monitoring of power quality characteristics, e.g. harmonics up to 40th harmonic
- Residual current monitoring (RCM)

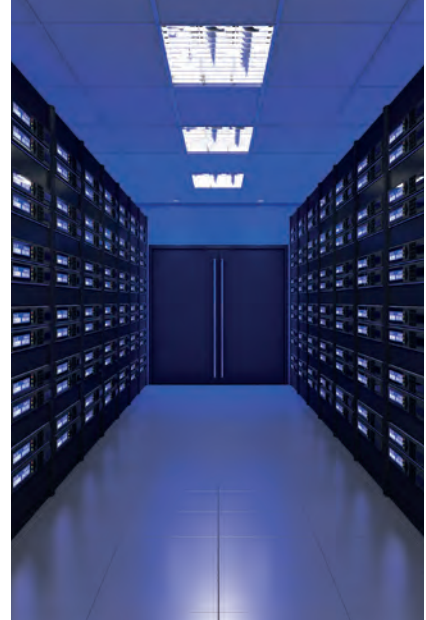

Main features

Universal meter

- Operating current monitoring for general electrical parameters
- High transparency through a multi-stage and scalable measurement system in the field of energy measurement
- Acquisition of events through continuous measurement with 200 ms high resolution



RCM device

- Continuous monitoring of residual currents (Residual Current Monitor, RCM)
- Alarming in case a preset threshold fault current reached
- Near-realtime reactions for triggering countermeasures
- Permanent RCM measurement for systems in permanent operation without the opportunity to switch off

Energy measurement device

- Continuous acquisition of the energy data and load profiles
- Essential both in relation to energy efficiency and for the safe design of power distribution systems



Harmonics analyser / event recorder

- Analysis of individual harmonics for current and voltage
- Prevention of production downtimes
- Significantly longer service life for equipment
- Rapid identification and analysis of power quality fluctuations by means of user-friendly tools (GridVis®)

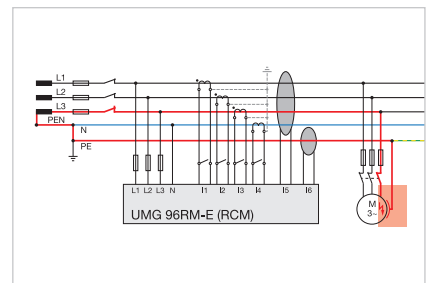

Fig.: UMG 96RM-E with residual current monitoring via measuring inputs I5 / I6

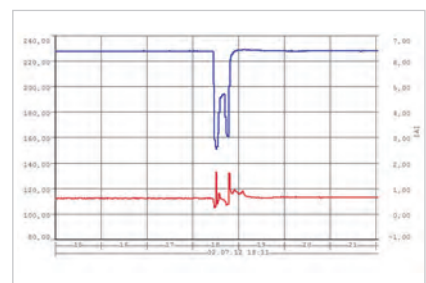

Fig.: Event logger: Voltage dip in the low voltage distribution system

7
Tariffs

Extensive selection of tariffs

- 7 tariffs each for effective energy (consumption, delivery and without backstop)
- 7 tariffs each for reactive energy (inductive, capacitive and without backstop)
- 7 tariffs for apparent energy
- L1, L2 and L3, for each phase

Highest possible degree of reliability

- Continuous leakage current measurement
- Historical data: Long-term monitoring of the residual current allows changes to be identified in good time, e.g. insulation faults
- Time characteristics: Recognition of time relationships
- Prevention of neutral conductor carryover
- RCM threshold values can be optimized for each individual case: Fixed, dynamic and stepped RCM threshold value
- Monitoring of the CGP (central ground point) and the sub-distribution panels

Analysis of fault current events

- Event list with time stamp and values
- Presentation of fault currents with characteristic and duration
- Reproduction of phase currents during the fault current surge
- Presentation of the phase voltages during the fault current surge

Analysis of the harmonic fault current components

- Frequencies of the fault currents (fault type)
- Current peaks of the individual frequency components in A and %
- Harmonics analysis up to 40th harmonic
- Maximum values with real-time bar display

Digital IOs

- Extensive configuration of IOs for intelligent integration, alarm and control tasks

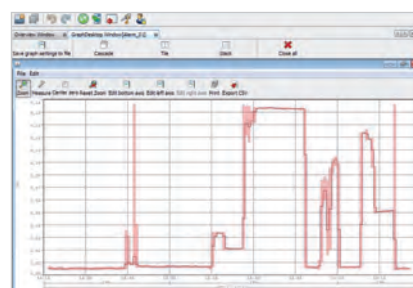

Fig.: Continuous leakage current measurement

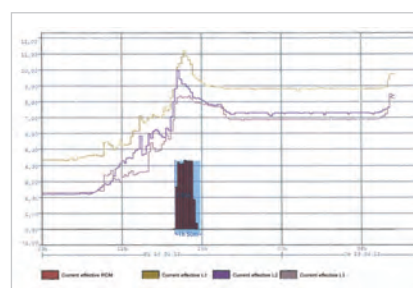

Fig.: Analysis of fault current events

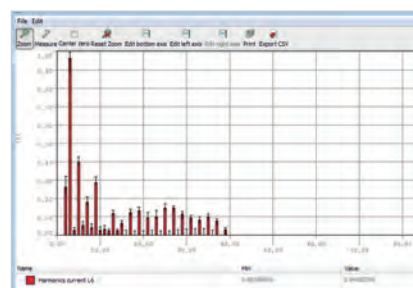

Fig.: Analysis of the harmonic fault current components



Ethernet (TCP/IP)- / Homepage- / Ethernet-Modbus gateway functionality

- Simple integration into the network
- More rapid and reliable data transfer
- Modern homepage
- World-wide access to measured values by means of standard web browsers via the device's inbuilt homepage
- Access to measurement data via various channels
- Reliable saving of measurement data possible over a very long periods of time in the 256 MByte measurement data memory
- Connection of Modbus slave devices via Ethernet-Modbus gateway



Fig.: Ethernet-Modbus gateway functionality



Measuring device homepage

- Webserver on the measuring device, i.e. device's own homepage
- Remote operation of the device display via the homepage
- Comprehensive measurement data incl. PQ
- Online data directly available via the homepage, historic data optional via the APP measured value monitor, 51.00.246

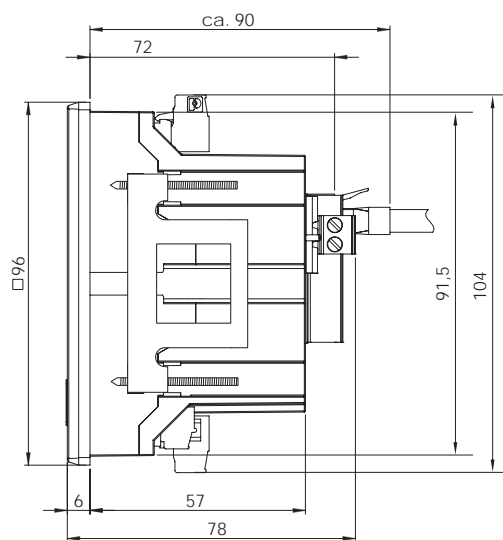

Fig.: Illustration of the online data via the device's inbuilt homepage



Dimension diagrams

All dimensions in mm



Side view

Cut out: 92^{+0.8} x 92^{+0.8} mm

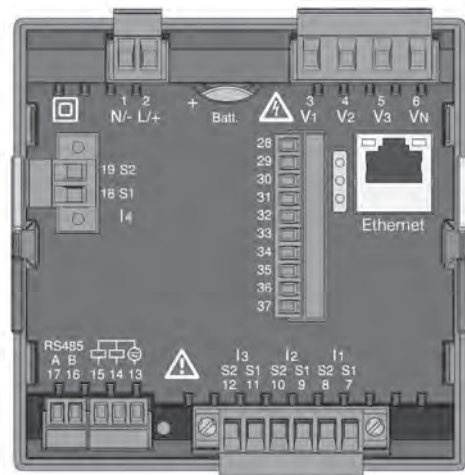

Rear view



Typical connection

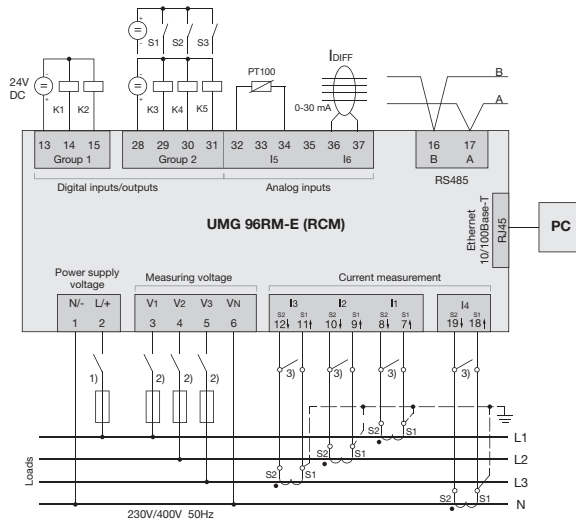

Fig.: Connection example with temperature and residual current measurement



Device overview and technical data

	UMG 96RM-E ^{*1}
Item number (90–277 V AC / 90–250 V DC)	52.22.062
Item number (24–90 V AC / 24–90 V DC)	52.22.063
General	
Use in low and medium voltage networks	•
Accuracy voltage measurement	0.2 %
Accuracy current measurement	0.2 %
Accuracy active energy (kWh, .../5 A)	Class 0.5S
Number of measurement points per period	426
Uninterrupted measurement	•
RMS - momentary value	
Current, voltage, frequency	•
Active, reactive and apparent power / total and per phase	•
Power factor / total and per phase	•
Energy measurement	
Active, reactive and apparent energy [L1, L2, L3, Σ L1–L3]	•
Number of tariffs	14
Recording of the mean values	
Voltage, current / actual and maximum	•
Active, reactive and apparent power / actual and maximum	•
Frequency / actual and maximum	•
Demand calculation mode (bi-metallic function) / thermal	•

Comment:
For detailed technical information please refer to the operation manual and the Modbus address list.

• = included - = not included

*1 Inclusive UL certification.

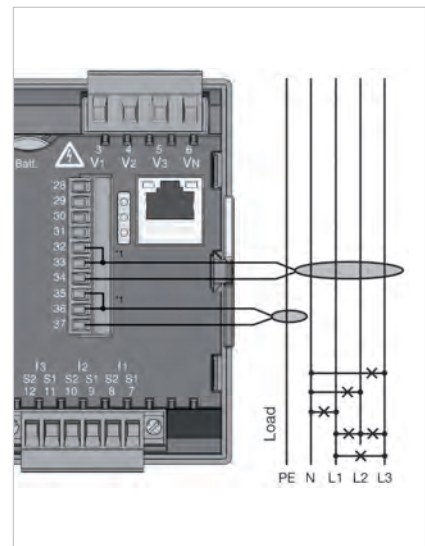

Fig.: Connection example residual current measurement and PE monitoring

Other measurements	
Operating hours measurement	•
Clock	•
Power quality measurements	
Harmonics per order / current and voltage	1st – 40th
Distortion factor THD-U in %	•
Distortion factor THD-I in %	•
Rotary field indication	•
Current and voltage, positive, zero and negative sequence component	•
Error / event recorder function	•
Under and overvoltage recording	•
Measured data recording	
Memory (Flash)	256 MB
Average, minimum, maximum values	•
Current measurement channel	4 (+2)
Alarm messages	•
Time stamp	•
Time basis average value	freely user-defined
RMS averaging, arithmetic	•
Displays and inputs / outputs	
LCD display (with backlighting), 2 buttons	•
Digital outputs (as switch or pulse output)	2
Digital inputs and outputs (selectable)	3
Analogue inputs (RCM, temperature, analogue)	2
Voltage inputs	L1, L2, L3 + N
Password protection	•
Communication	
Interfaces	
RS485: 9.6 – 115.2 kbps (Screw-type terminal)	•
Ethernet 10/100 Base-TX (RJ-45 socket)	•
Protocols	
Modbus RTU	•
Modbus TCP/IP	•
Modbus RTU over Ethernet	•
Modbus Gateway for Master-Slave configuration	•
HTTP (homepage configurable)	•
SMTP (email)	•
NTP (time synchronisation)	•
TFTP	•
FTP (File-Transfer)	•
SNMP	•
DHCP	•
BACnet (optional)	•
ICMP (Ping)	•
Software GridVis®-Basic*2	
Online and historic graphs	•
Databases (Janitza DB, Derby DB); MySQL, MS SQL with higher GridVis® versions)	•
Manual reports (energy, power quality)	•
Topology views	•
Manual read-out of the measuring devices	•
Graph sets	•
Programming / threshold values / alarm management	
Comparator (5 Groups with 10 comparators each)	•
Comprehensive adjustment options for RCM	•

Comment:
For detailed technical information please refer to the operation manual and the Modbus address list.

• = included - = not included

*2 Optional additional functions with the packages GridVis®-Professional, GridVis®-Service and GridVis®-Ultimate.

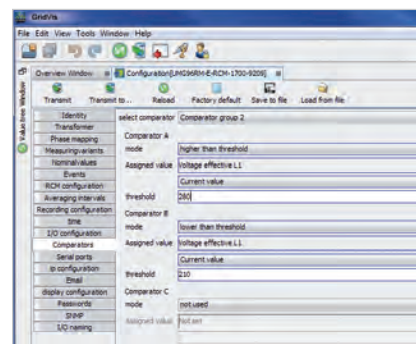

Fig.: GridVis® software, configuration menu

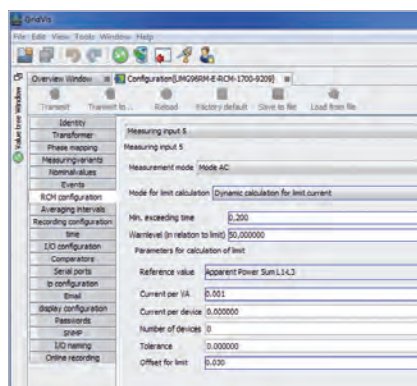

Fig.: RCM configuration, e.g. dynamic threshold value formation, for load-dependent threshold value adaptation



Fig.: Summation current transformer for the acquisition of residual currents. Wide range with different configurations and sizes allow use in almost all applications

Technical data	
Type of measurement	Constant true RMS Up to 40th harmonic
Nominal voltage, three-phase, 4-conductor (L-N, L-L)	277 / 480 V AC
Nominal voltage, three-phase, 3-conductor (L-L)	480 V AC
Measurement in quadrants	4
Networks	TN, TT, IT
Measured voltage input	
Overvoltage category	300 V CAT III
Measured range, voltage L-N, AC (without potential transformer)	10 ... 300 Vrms
Measured range, voltage L-L, AC (without potential transformer)	18 ... 520 Vrms
Resolution	0.01 V
Impedance	4 MOhm / phase
Frequency measuring range	45 ... 65 Hz
Power consumption	approx. 0.1 VA
Sampling frequency per channel (50 / 60 Hz)	21.33 / 25.6 kHz
Measured current input	
Rated current	1 / 5 A
Resolution	0.1 mA
Measurement range	0.001 ... 6 Amps
Overvoltage category	300 V CAT II
Measurement surge voltage	2 kV
Power consumption	approx. 0.2 VA (Ri = 5 mOhm)
Overload for 1 sec.	120 A (sinusoidal)
Sampling frequency per channel (50 / 60 Hz)	21.33 / 25.6 kHz
Residual current input	
Analogue inputs	2 (for residual current or temperature measurement)
Measurement range, residual current input*3	0.05 ... 30 mA
Digital outputs	
Switching voltage	max. 60 V DC, 33 V AC
Switching current	max. 50 mA Eff AC / DC
Response time	10 / 12 periods + 10 ms
Pulse output (energy pulse)	max. 50 Hz
Maximum cable length	up to 30 m unshielded, from 30 m shielded
Mechanical properties	
Weight	approx. 370 g
Device dimensions in mm (H x W x D)*4	96 x 96 x 78
Battery	CR2032, 3 V, type Lithium
Protection class per EN 60529	Front: IP40; Back: IP20
Assembly per IEC EN 60999-1 / DIN EN 50022	Front panel installation
Cable cross section	
Supply voltage	0.2 to 2.5 mm ²
Current measurement	0.2 to 2.5 mm ²
Voltage measurement	0.08 to 4.0 mm ²
Environmental conditions	
Temperature range	Operation: K55 (-10 ... +70 °C)
Relative humidity	Operation: 0 to 75 % RH
Operating height	0 ... 2,000 m above sea level
Degree of pollution	2
Installation position	user-defined
Electromagnetic compatibility	
Electromagnetic compatibility of electrical equipment	Directive 2004/108/EC
Electrical appliances for application within particular voltage limits	Directive 2006/95/EC

Comment:

For detailed technical information please refer to the operation manual and the Modbus address list.

• = included - = not included

*3 Example of residual current input 30 mA with 600/1 residual current transformer: 600 x 30 mA = 18,000 mA

*4 Accurate device dimensions can be found in the operation manual.

Equipment safety	
Safety requirements for electrical equipment for measurement, regulation, control and laboratory use – Part 1: General requirements	IEC/EN 61010-1
Part 2-030: Particular requirements for testing and measuring circuits	IEC/EN 61010-2-030
Noise immunity	
Class A: Industrial environment	IEC/EN 61326-1
Electrostatic discharge	IEC/EN 61000-4-2
Voltage dips	IEC/EN 61000-4-11
Emissions	
Class B: Residential environment	IEC/EN 61326-1
Radio disturbance voltage strength 30 – 1000 MHz	IEC/CISPR11/EN 55011
Radiated interference voltage 0.15 – 30 MHz	IEC/CISPR11/EN 55011
Safety	
Europe	CE labelling
Firmware	
Firmware update	Update via GridVis® software. Firmware download (free of charge) from the website: http://www.janitza.com

Comment:
For detailed technical information please refer to the operation manual and the Modbus address list.

• = included - = not included

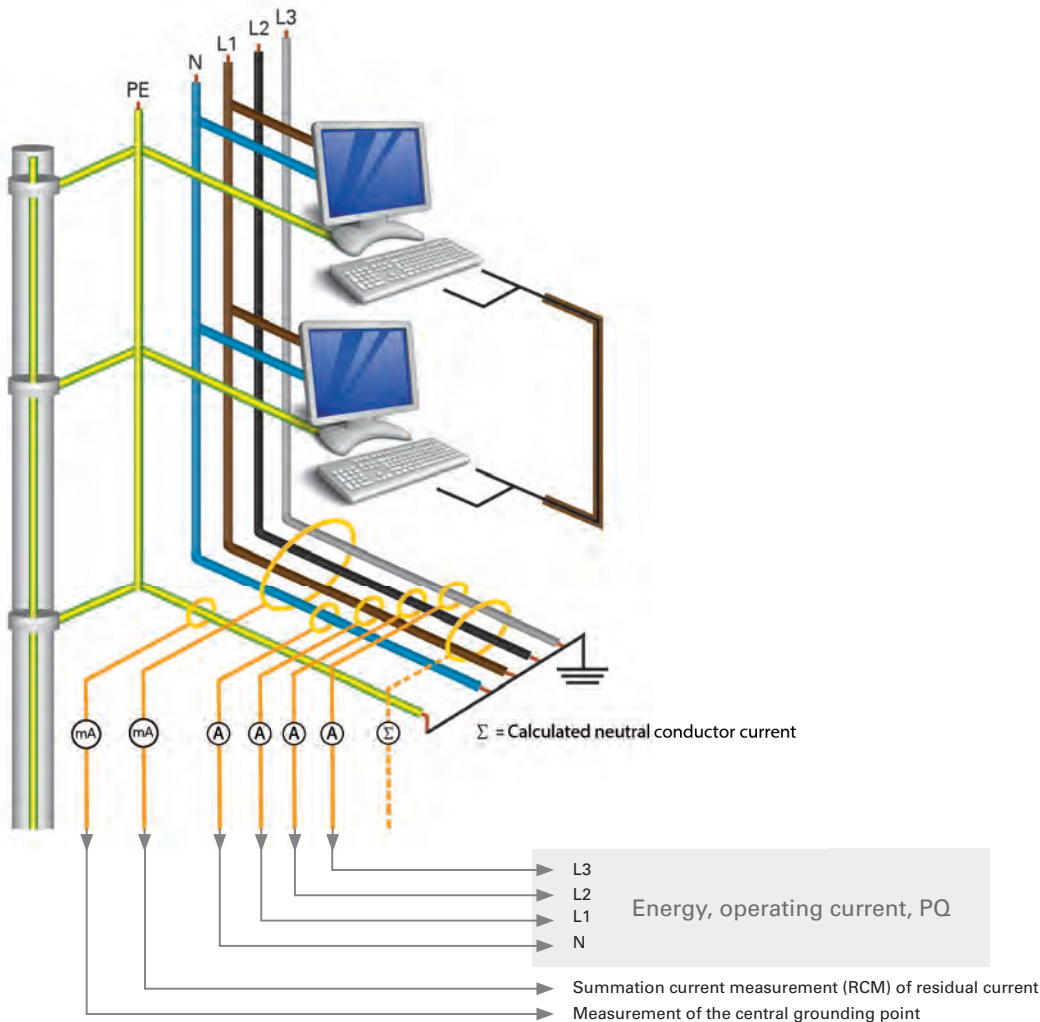

Janitza electronics GmbH
Vor dem Polstück 6 | 35633 Lahnau
Deutschland

Tel.: +49 6441 9642-0
Fax: +49 6441 9642-30
info@janitza.com | www.janitza.com

Sales partner

Item no.: 33.03.753 • Dok-Nr.: 2.500.082.7 • Stand 01/2017 • Subject to technical alterations.
The current brochure is always available for you under www.janitza.com