

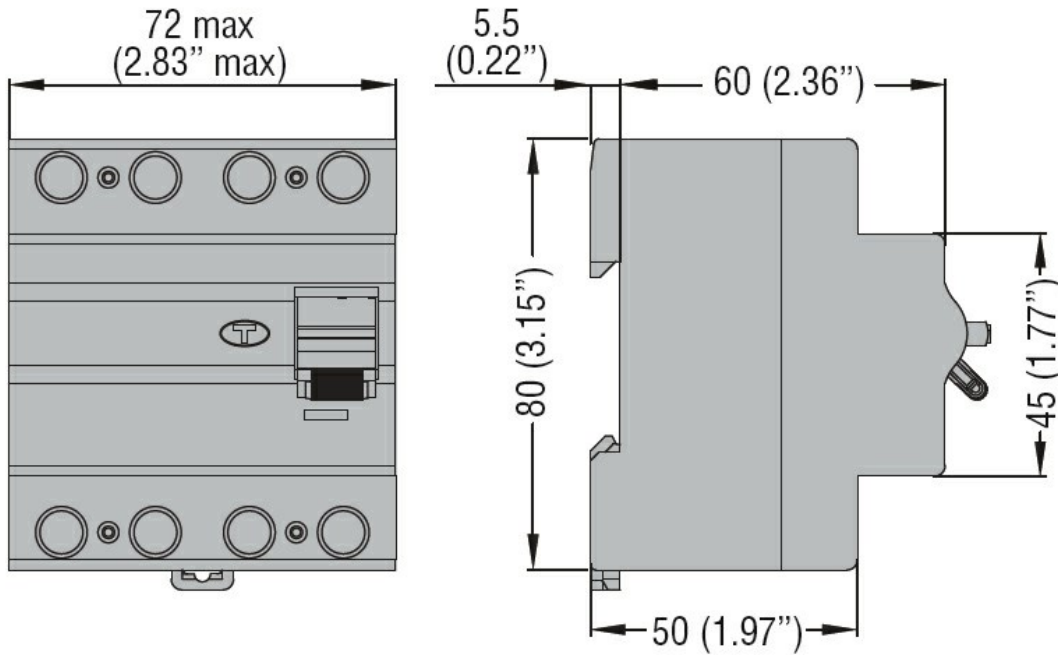

Product designation	Residual current circuit breakers (RCCB)		
Product type designation	P1 RC		
Number of poles	4P		
Number of DIN modules	4		
Compliance	IEC		
Electrical features			
Rated insulation voltage U_i IEC/EN	V	400	
Rated impulse withstand voltage U_{imp}	kV	4	
Rated operational voltage AC (IEC)	VAC	230/400	
Rated frequency	Hz	50/60	
Rated current (I_n)	A	40	
Residual operation characteristic	AC		
Rated residual current	mA	300	
Power dissipation per pole max	W	1.2	
Ambient conditions			
Operating temperature	min	°C	-35
	max	°C	70
Storage temperature	min	°C	-40
	max	°C	80
Max altitude	m	2000	
Mechanical features			
Operating position	normal	Vertical plan	
Fixing	35mm DIN rail		
Tightening torque for terminals	min	Nm	1.8
	max	Nm	2
	min	lbin	16
	max	lbin	17.7
Terminals tool	Pz 2		
Conductor section	IEC		
	min	mm ²	2.5
	max	mm ²	35
	AWG/Kcmil		
min	14		
max	2		
Weight	g	326	
Frontal IP degree	IP20		
Pollution degree	2		
Dimensions			



Certifications and compliance

Compliance

IEC/EN/BS 61008-1

Certifications

EAC

TÜV-SUD

ETIM classification

ETIM 8.0

EC000003 -
Residual current
circuit breaker
(RCCB)