



Low Voltage Power Capacitors Data Book

ESTAprop/ESTAdry

- PhMKP, PhMKPg..., Cylindrical, LVAC
- PhMKDg..., Triangular, LVAC
- PhMKP..., Rectangular, LVAC
- PhMKP.../-DW, LVAC

Low Voltage Power Capacitors

GENERAL TECHNICAL INFORMATION

MKP-technology	3
Self-healing	3
Filling agent (ESTAprop, ESTAdry).....	3
Providing the winding element with electronic contacts.....	3
Overpressure tear-off fuse.....	4
Characteristics of dielectric	4
CE-marking	4
UL- and ULC-marking	4

TERMS AND DEFINITIONS, APPLICABLE STANDARDS

Definition of ratings.....	5
Maximum permissible current	5
Maximum permissible voltage	5
Harmonic distortion	5
Damping of inrush current	5
Operating temperatures.....	6
Degree of protection, IP code.....	6

CALCULATION AND TABLES

Capacitor selection table for power factor correction of electrical motors	7
Capacitor selection table for power factor correction of transformers.....	7
Calculation and selection of required capacitor rating	8
Discharge resistors	9
Cross section of connecting cable between main supply and capacitor bank, fuse rating	10
Calculation of the required rated capacitor output in detuned filter circuits	11

PhMKP, PhMKPg..., CYLINDRICAL, LVAC

Quick reference data	12
Application	13
Design	13
Technical data.....	14
Range of 3-phase types, IP00, oil	
- 230 V, 400 V (415 V), 440 V (415 V), 525 V (480 V)	15
- 660 V (690 V), 690 V (660 V).....	16
Range of 3-phase types, IP20, oil	
- 230 V, 400 V (415 V).....	17
- 440 V (415 V).....	18
- 525 V (480 V).....	19
- 660 V (690 V), 690 V (660 V).....	20
Range of 3-phase types, IP00, dry	
- 230 V, 400 V (415 V), 440 V (415 V), 525 V (480 V)	21
- 660 V (690 V), 690 V (660 V).....	22
Range of 3-phase types, IP20, dry	
- 230 V, 400 V (415 V).....	23
- 440 V (415 V).....	24
- 525 V (480 V).....	25
- 660 V (690 V), 690 V (660 V).....	26
Range of 1-phase types, oil	
- 230 V, 400 V (415 V), 525 V (480 V).....	27
Dimensions	28

PhMKDg..., TRIANGULAR, LVAC

Quick reference data	29
Application	29
Description.....	30
Technical data, D-type PhMKDg, indoor.....	31
Range of 3-phase types	
- 400 V, 440 V, 440 V (415 V), 460 V, 525 V, 690 V, 760 V	31
Dimensions, indoor	32
Discharge resistors	32
Technical data, D-type PhMKDgF, outdoor	33
Dimensions, outdoor.....	34
Accessories.....	34

PhMKP..., RECTANGULAR, LVAC

Quick reference data	35
Application	35
Description.....	36
Design	36
Technical data.....	37
Range of types	
- Delta connection, IP43.....	38
- Delta connection, IP00.....	38
Dimensions	39

PhMKP.../-DW, LVAC

Quick reference data	40
Application	41
Design	41
Technical data.....	42
Dimensions	43

Low Voltage Power Capacitors

GENERAL TECHNICAL INFORMATION

MKP-TECHNOLOGY

Capacitors are used in many diverse applications, and many different capacitor technologies are available. In low voltage applications, MKP-type capacitors which are made in accordance with metallized polypropylene technology have proved to be most appropriate and also the most cost effective. Dependent on the nominal voltage of the capacitor, the thickness of the polypropylene film will differ.

MKP-TYPE CAPACITOR (metallized polypropylene film)

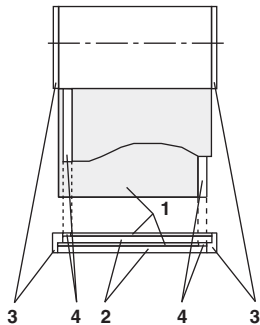

Design of a MKP-type capacitor

- 1 Electrodes (metallized)
- 2 Polypropylene film
- 3 Electric contact (schooping)
- 4 Non-metallized edge

SELF-HEALING

At the end of service life, or due to inadmissible electrical or thermal overload, an insulation breakdown may occur. A breakdown causes a small arc which evaporates the metal layer around the point of breakdown and re-establishes the insulation at the place of perforation. After electric breakdown, the capacitor can still be used. The decrease of capacitance caused by a self-healing process is less than 100 pF. The self-healing process lasts for a few microseconds only and the energy necessary for healing can be measured only by means of sensitive instruments.

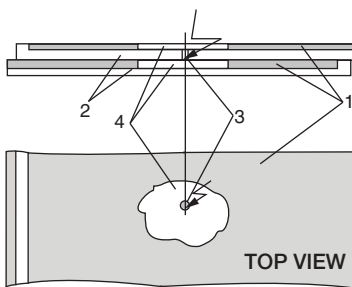

Self-healing breakdown

- 1 Electrodes (metallized)
- 2 Polypropylene film
- 3 Point of breakdown
- 4 Non-conductive insulating area

FILLING AGENT

ESTAprop

ESTAprop MKP-type capacitors are filled with a natural oil. The highly fire-resisting insulation oil on vegetable base (flash point 285 °C, ignition point 315 °C) is fully biodegradable and non-toxic.

After an extended drying period, the filling of the capacitor casing with oil is carried out under high vacuum for removal of moisture. Following this process, the capacitor will be hermetically sealed. This process ensures excellent heat dissipation and constant capacitance over full service life.

ESTAdry

ESTAdry MKP-type capacitors are “dry”. That is, after the extended drying period and before the hermetic sealing of the casing, a non-liquid filling agent is used instead of natural oil. In case of tubular cans, it is an environmentally friendly inert gas-filling to avoid corrosion of the winding elements and inner electric contacts. For larger dry capacitors, e.g. the D-type capacitors or the DW-type filter capacitors, the filling agent is a resin.

A little “g” shows the difference in the type designation between the oil-filled (PhMKP) and the dry version (PhMKPg).

Both versions comply with the highest temperature class D, specified by the standards.

PROVIDING THE WINDING ELEMENT WITH ELECTRIC CONTACTS

For ESTAprop and ESTAdry MKP-type capacitors, metallized electrodes are used. A winding element consists of two displaced polypropylene films, wound together. The front surface of the winding elements is joined by means of a metal spray process. This process is called schooping. Due to the displacement of the two polypropylene films, only one film will be electrically connected on one side of the element. The terminal leads can be soldered onto this sprayed metal surface.

OVERPRESSURE TEAR-OFF FUSE OPERATING CONDITION

At the end of service life, due to inadmissible electrical or thermal overload, an overpressure builds up and causes an expansion of the cover. Expansion over a certain limit causes the tear-off of the internal fuses. The active capacitor elements are thus cut off from the source of supply. The pressure within the casing separates the breaking point so rapidly that no harmful arc can occur.

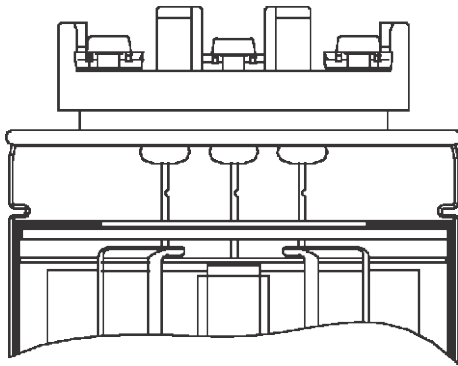

TORN-OFF CONDITION

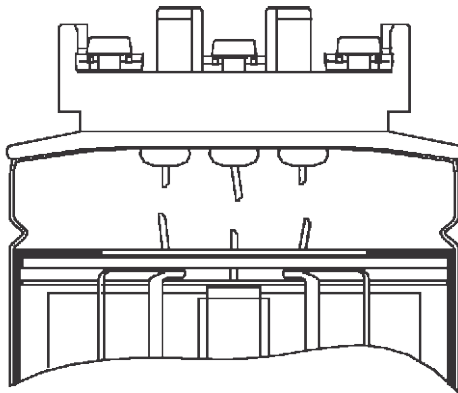

CE-MARKING

ESTAprop Low voltage capacitors conform with the regulations of the following European directive:

73/23 EEC Low Voltage Directive

All ESTAprop and ESTAdry low voltage power factor correction capacitors are supplied with CE-marking.

CHARACTERISTICS OF DIELECTRIC MKP-POLYPROPYLENE, METALLIZED

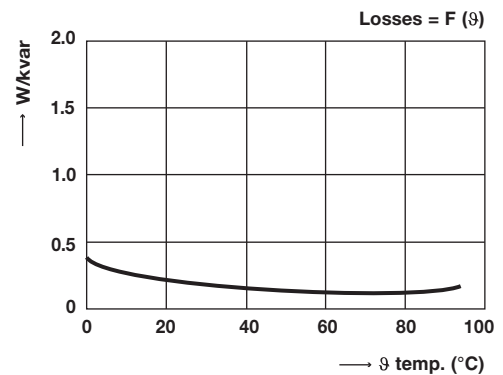
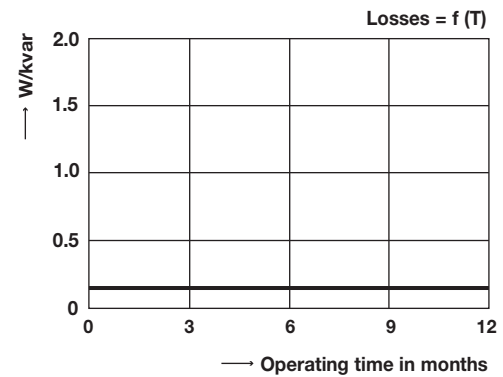
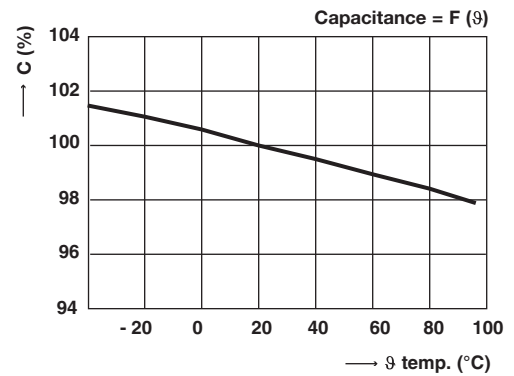

UL- AND ULC-MARKING

ESATAprop and ESTAdry cylindrical type capacitors have been tested and approved by independent laboratories such as Underwriters Laboratories Inc. (UL). ESTAprop and ESTAdry low voltage capacitors conform with UL standard 810 and Canadian standard C 22.2. UL and ULC marks are included in standard component marking.

Low Voltage Power Capacitors

TERMS AND DEFINITIONS, APPLICABLE STANDARDS

ESTAprop and ESTAdry power factor correction capacitors are designed to VDE 0560-46 + 47, IEC 60831-1 + 2 and EN 60831-1 + 2, latest edition.

DEFINITION OF RATINGS

- U_{cn} rated voltage: the RMS value of the alternating voltage ...
- I_n rated current: the RMS value of the alternating current ...
- C_n rated capacitance: the capacitance value ...
... for which the capacitor has been designed.

MAXIMUM PERMISSIBLE CURRENT

ESTAprop and ESTAdry MKP-type capacitors are suitable for continuous operation at an RMS line current of 1.3 times the fundamental current that occurs at rated sinusoidal

voltage and rated frequency, excluding transients. Taking into account a previous capacitance tolerance of $1.15 \times C_n$, the maximum current can reach $1.5 \times I_n$.

These overcurrent factors are intended to take into account the combined effects of harmonics, overvoltages and capacitance tolerance.

MAXIMUM PERMISSIBLE VOLTAGE

ESTAprop and ESTAdry MKP-type capacitors are suitable for operation at voltage levels as indicated in the table (extract from IEC 60831-1 clause 20 - table 3) below:

FREQUENCY RMS	VOLTAGE FACTOR U_{cn}	MAXIMUM DURATION	OBSERVATION
Power frequency	1.0	Continuous	Highest average value during any period of capacitor energization
Power frequency	1.10	8 h in every 24 h	System voltage regulation and fluctuations
Power frequency	1.15	30 min in every 24 h	System voltage regulation and fluctuations
Power frequency	1.20	5 min (only 200 times in the life of the capacitor)	Voltage rise at light load
Power frequency	1.30	1 min (only 200 times in the life of the capacitor)	
Power frequency and Harmonics	Such that the current does not exceed the value given above.		

HARMONIC DISTORTION

Capacitors can be overloaded in networks distorted by harmonics. This situation is even more critical in the case of resonance. Where the capacitor current or voltage can be a few times as high as the nominal voltage. Therefore, special precautions (e.g. series filter circuit reactors) should be taken in networks distorted by harmonics. Our warranty only applies for operating conditions in accordance with the above mentioned standards.

DAMPING OF INRUSH CURRENT

Switching devices especially suited for capacitor switching shall be used. For example, the device shall be such that restriking during breaking operations, which may result in high overvoltages, cannot occur.

The operating experience of ESTAprop MKP-type capacitors since their introduction in 1978 has shown their excellent behavior when being switched.

High output densities and reduction of losses have resulted in reduced resistance of modern MKP-type capacitors. Especially switching capacitors in parallel to others being already energized, cause very high inrush currents which

should be reduced to $\leq 100 \times I_n$ (according to standard). As a consequence, the life cycle of contactors and also capacitors will be affected.

In case of detuned capacitor banks, the inrush current will be limited by the inductivity of the series filter reactors.

For capacitor banks without filter reactors, we recommend the use of capacitor contactors with series resistors.

We recommend these special contactors instead of damping the inrush current by coiling up the connection cable between contactor and capacitor. This is due to superior damping behavior and reduced losses in connecting cables, resulting in temperature reduction inside the cubicle.

Contactors have to be replaced after about 100 000 switching operations.

Modern PFC controllers are able to memorize the switching number per capacitor step.

A regular check of the contactors is strongly recommended.

OPERATING TEMPERATURES

Capacitors are classified for ambient temperature categories, each category being specified by a number followed by a letter. The number represents the lowest ambient-air temperature at which the capacitor may be operated.

The letter represents upper limit of operating temperature, having maximum values specified in the table below.

	AMBIENT TEMPERATURE °C		
	MAXIMUM	MAXIMUM AVERAGE OVER	
		24 h	1 YEAR
A	40	30	20
B	45	35	25
C	50	40	30
D	55	45	35

ESTAprop and ESTAdry, PhMKP-type, cylindrical capacitors are designed for category: - 25/D (ESTAprop), - 40/D (ESTAdry)

DEGREE OF PROTECTION, IP CODE

Degrees of protection are described by the IP code. The designation consists of the letters "IP" followed by two characteristic figures, e.g. "IP00" means no protection.

The first characteristic figure indicates that:

- the enclosure provides protection of persons against access to hazardous parts by preventing or limiting the ingress of a part of the human body or an object held by a person; and simultaneously

- the enclosure provides protection of equipment against the ingress of solid foreign objects.

The second characteristic figure indicates the degree of protection provided by enclosures with respect to harmful effects on the equipment due to the ingress of water.

CHARACTERISTIC NUMERICAL	1 st	2 nd
	PROTECTION AGAINST ACCESS TO HAZARDOUS PARTS AND PENETRATION OF SOLID FOREIGN OBJECTS INCLUDING DUST	PROTECTION AGAINST INGRESS OF WATER
0	No protection	No protection
1	Protected against solid foreign objects of 50 mm Ø and greater	Protected against vertically falling water drops
2	Protected against solid foreign objects of 12.5 mm Ø and greater	Protected against vertically falling water drops when enclosure tilted up to 15°
3	Protected against solid foreign objects of 2.5 mm Ø and greater	Protected against spraying water
4	Protected against solid foreign objects of 1 mm Ø and greater	Protected against splashing water
5	Dust-protected	Protected against water jets
6	Dust-tight	Protected against powerful water jets

Low Voltage Power Capacitors

CAPACITOR SELECTION TABLE FOR POWER FACTOR CORRECTION OF ELECTRICAL MOTORS

Reactive power is required by an asynchronous motor for the magnetic field. The amount of reactive power consumption of a motor depends on various parameters such as power rating, loading, rated speed, and design. The capacitor output should be maximum 90 % of the apparent power of a asynchronous motor under no-load conditions.

This is important to avoid dangerous self excitation of the motor. A measurement of the motor current under no-load conditions can be easily performed or may be obtained from the manufacturer.

GUIDELINE VALUES FOR CAPACITOR SELECTION	
MOTOR POWER RATING kW	CAPACITOR OUTPUT SELECTION kvar
up to 3.9	Approximately 55 % of nominal motor power
4.0 to 4.9	2
5.0 to 5.9	2.5
6.0 to 7.9	4
8.0 to 10.9	4
11.0 to 13.9	5
14.0 to 17.9	6
18.0 to 21.9	7.5
22.0 to 29.9	10
30.0 and above	Approximately 35 % of nominal motor power

CAPACITOR SELECTION TABLE FOR POWER FACTOR CORRECTION OF TRANSFORMERS

For power factor correction of transformers only the no-load reactive power has to be covered. The required capacitor output for three-phase transformers depends on the short-circuit voltage and is between 3 % and 12 % of the rated transformer output. In case harmonics are present on the high voltage side, the capacitor can form a series resonance circuit with the inductance of the transformer. Therefore the capacitor output has to be selected very carefully together with power utilities and the transformer manufacturer. The following formula can be used to check whether a certain capacitor output will create

problems for specific harmonic orders on high voltage side:

$$N = \sqrt{S/Q_C}$$

n = harmonic order

Q_C = rated capacitor output in kvar

S = short circuit power at the point of capacitor connection in kVA

GUIDELINE VALUES FOR CAPACITOR SELECTION			
TRANSFORMER RATING kVA	CAPACITOR OUTPUT IN kvar AT TRANSFORMER PRIMARY VOLTAGES		
	5 kV to 10 kV	15 kV to 20 kV	25 kV to 30 kV
50	4.0	5.0	6.0
75	5.0	6.0	7.5
100	6.0	7.5	10.0
160	10.0	12.5	15.0
250	15.0	16.7	20.0
315	16.7	20.0	25.0
400	20.0	25.0	30.0
630	30.0	33.3	40.0
1000	45.0	50.0	55.0
1250	50.0	55.0	60.0

CALCULATION AND SELECTION OF REQUIRED CAPACITOR RATING

$$Q_C = P \times (\tan \varphi_1 - \tan \varphi_2) = P \times (\tan \arccos \cos \varphi_1 - \tan \arccos \cos \varphi_2)$$

Q_C = required capacitor output (kvar)

P = real power (kW)

φ_1 = phase angle of actual power factor

φ_2 = phase angle of target power factor

$\cos \varphi_1$ = actual power factor

$\cos \varphi_2$ = target power factor

The table below shows the values for typical power factors according to the formula “ $\tan \varphi_1 - \tan \varphi_2$ ”:

	TARGET POWER FACTOR										
	0.70	0.75	0.80	0.85	0.90	0.92	0.94	0.96	0.98	1.00	
ACTUAL POWER FACTOR											
0.40	1.27	1.41	1.54	1.67	1.81	1.87	1.93	2.00	2.09	2.29	
0.45	0.96	1.10	1.23	1.36	1.50	1.56	1.62	1.69	1.78	1.98	
0.50	0.71	0.85	0.98	1.11	1.25	1.31	1.37	1.44	1.53	1.73	
0.55	0.50	0.64	0.77	0.90	1.03	1.09	1.16	1.23	1.32	1.52	
0.60	0.31	0.45	0.58	0.71	0.85	0.91	0.97	1.04	1.13	1.33	
0.65	0.15	0.29	0.42	0.55	0.68	0.74	0.81	0.88	0.97	1.17	
0.70	0.00	0.14	0.27	0.40	0.54	0.59	0.66	0.73	0.82	1.02	
0.75		0.00	0.13	0.26	0.40	0.46	0.52	0.59	0.68	0.88	
0.80			0.00	0.13	0.27	0.32	0.39	0.46	0.55	0.75	
0.85				0.00	0.14	0.19	0.26	0.33	0.42	0.62	
0.90					0.00	0.06	0.12	0.19	0.28	0.48	

The required capacitor output may be calculated as follows:

select the factor k
(matching point of actual and target power factor)

calculate the required capacitor rating with the formula:

$$Q_C = k \times P$$

Example: actual power factor = 0.70

target power factor = 0.96

real power $P = 35$ kW

capacitor output $Q_C = ?$

$$Q_C = k \times P = 0.73 \times 35 \text{ kW} = 25.5 \text{ kvar}$$

Capacitor output in case of voltage and/or frequency different to the capacitor nominal voltage:

$$Q_{\text{new}} = \left(\frac{U_{\text{new}}}{U_{\text{cn}}} \right)^2 \times \frac{f_{\text{new}}}{f_{\text{cn}}} \times Q_{\text{cn}}$$

Note $U_{\text{new}} < U_{\text{cn}}$

U_{new} = supply voltage the capacitor is required for

f_{new} = frequency the capacitor is required for

Q_{new} = capacitor output at U_{new} and f_{new}

U_{cn} = rated capacitor voltage

f_{cn} = rated capacitor frequency

Q_{cn} = rated capacitor output at U_{cn} and f_{cn}

DISCHARGE RESISTORS

ESTAprop MKP-type capacitors will be provided complete with discharge resistors. After the capacitor is disconnected from the source of supply, discharge resistors are required for discharging each unit within 3 min to 75 V or less from initial nominal peak voltage (according IEC-standard 60831-1 + 2). Discharge resistors have to be connected directly to the capacitors. There shall be no switch, fuse cut-out, or any other isolating device between the capacitor unit and the discharge resistors.

Annotation: Our capacitors are discharged to 50 V or less within 1 min to comply also with UL standard 810.

MAXIMUM RESISTOR VALUE

$$R \leq \frac{60 \text{ s}}{C_n \times I_n \left(\frac{U_n \times \sqrt{2}}{50 \text{ V}} \right)}$$

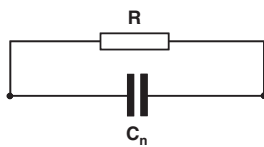
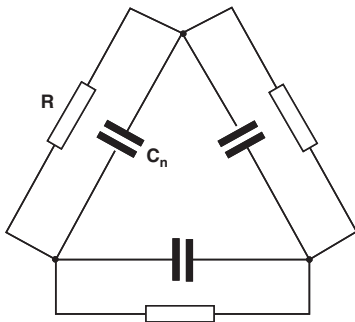

MINIMUM REQUIRED POWER RATING OF THE RESISTORS (W)

$$P = \frac{U^2}{R}$$

MAXIMUM RESISTOR VALUE

$$R \leq \frac{60 \text{ s}}{1/3 \times C_n \times I_n \left(\frac{U_n \times \sqrt{2}}{50 \text{ V}} \right)}$$

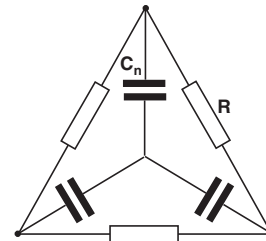

Example: PhMKP 400.3.25
(Delta Connection)

$$C_n = 165.8 \mu\text{F}$$

$$\Rightarrow R \leq \frac{60 \text{ s}}{165.8 \times 10^{-6} \text{ F} \times I_n \left(\frac{400 \text{ V} \times \sqrt{2}}{50 \text{ V}} \right)}$$

$$R \leq 149.1 \text{ k}\Omega$$

(a thickfilm discharge resistor with 145 kΩ is used)

Note

- Attention: Terminals have to be short-circuited before handling.

CROSS SECTION OF CONNECTING CABLE BETWEEN MAIN SUPPLY AND CAPACITOR BANK, FUSE RATING

Cross section for connecting cable and fuse rating have to be selected in accordance with the standard VDE 0100 part 523. Values mentioned below are guideline values valid for operation under normal conditions and at an ambient

temperature of 40 °C. Higher values shall be selected if conditions differ from normal (e.g. high harmonic distortion or higher ambient temperature).

OUTPUT kvar	RATED VOLTAGE 230 V, 50 Hz			RATED VOLTAGE 400 V, 50 Hz			VOLTAGE 415 V, 50 Hz		
	RATED CURRENT A	FUSE A	CABLE/ mm ²	RATED CURRENT A	FUSE A	CABLE/ mm ²	RATED CURRENT A	FUSE A	CABLE/ mm ²
2.5	6.3	16	2.5	3.6	10	1.5	3.5	10	1.5
5.0	12.6	25	4	7.2	20	2.5	7.0	20	2.5
6.67	16.7	35	6	9.6	20	2.5	9.3	20	2.5
7.5	19	35	6	10.80	20	2.5	10.4	20	2.5
8.33	21	35	6	12	20	2.5	11.6	20	2.5
10.0	25	50	10	14.4	25	4	13.9	25	4
12.5	31	63	16	18	35	6	17.4	35	6
15.0	38	63	16	21.7	35	6	20.9	35	6
16.7	42	80	25	24.1	50	10	23.2	50	10
20.0	50	100	35	28.9	50	10	27.8	50	10
25.0	63	125	50	36.1	63	16	34.8	63	16
30.0	75	125	50	43.3	80	25	41.7	80	25
33.3	84	160	70	48.1	80	25	46.3	80	25
40.0	100	160	95	57.7	100	35	55.6	100	35
50.0	125	250	120	72.2	125	50	69.6	125	50
60.0	-	-	-	86.6	160	70	83.5	160	70
66.7	-	-	-	96.3	160	70	92.8	160	70
70.0	-	-	-	101	160	70	97	160	70
75.0	-	-	-	108	160	70	104	160	70
83.3	-	-	-	120	200	95	116	200	95
100.0	-	-	-	144	250	120	139	250	120

CAPACITOR BANK INTERNAL WIRING

The internal wiring of capacitor banks can be normally done with a lower cross section. Various parameters such as cabinet inside temperature, quality of cable, maximum cable isolation temperature, single or multicore cable, and temperature rating have to be taken into consideration for selection of the appropriate value.

The contrary requirement for limiting the inrush current and reduction of cable losses is another important aspect in this matter if no inrush current limiting devices are used.

CALCULATION OF THE REQUIRED RATED CAPACITOR OUTPUT IN DETUNED FILTER CIRCUITS (FACTORS TO BE MULTIPLIED WITH THE REQUIRED OUTPUT PER STEP)

SUPPLY VOLTAGE 400 V							
RATED VOLTAGE ⁽¹⁾ OF CAPACITOR V	DETUNING FACTOR IN %						
	5	5.5	6	7	12.5	13	14
440	1.150	1.143	1.137	1.125	-	-	-
525	1.637	1.628	1.619	1.602	1.507	1.499	1.481

SUPPLY VOLTAGE 415 V							
RATED VOLTAGE ⁽¹⁾ OF CAPACITOR V	DETUNING FACTOR IN %						
	5	5.5	6	7	12.5	13	14
440	1.068	1.062	1.057	-	-	-	-
525	1.520	1.512	1.504	1.488	1.400	1.392	1.376

SUPPLY VOLTAGE 440 V							
RATED VOLTAGE ⁽¹⁾ OF CAPACITOR V	DETUNING FACTOR IN %						
	5	5.5	6	7	12.5	13	14
525	1.352	1.345	1.338	1.324	1.246	1.239	1.224

SUPPLY VOLTAGE 480 V							
RATED VOLTAGE ⁽¹⁾ OF CAPACITOR V	DETUNING FACTOR IN %						
	5	5.5	6	7	12.5	13	14
525	1.136	1.130	1.125	1.113	-	-	-
660	1.796	1.787	1.777	1.758	1.654	1.645	1.626

Example:

Required output per step at supply voltage: 50 kvar

Supply voltage: 400 V

Detuning factor: 7 %

Rated voltage of the capacitor: 440 V

Factor of the table: 1.125

Required rated output of the capacitors: 50 kvar x 1.125 = 56.25 kvar

Selection: for instance: 2 x PhMKP 440.3.28, 1

Note

⁽¹⁾ For filter circuits the capacitor rated voltage has to be chosen always higher than the supply voltage.
i.e.: Fundamental voltage increased by the reactor and harmonics.

LVAC Power Capacitors



FEATURES

- Self-healing technology
- Over pressure tear-off fuse
- Aluminum case
- Excellent heat dissipation
- Various design options: Slim diameter or low height, screw terminal IP00 or terminal block IP20
- Two versions available: Oil-filled and dry, gas filled
- UL and cUL approved

APPLICATIONS

- For applications 1-phase or 3-phase $\leq 1000 \text{ VAC}_{\text{RMS}}$
- Free standing, fixed individual-PFC (e.g. motors, lighting, transformers)
- Automatic central-PFC (e.g. group of loads)
- Harmonic trap (e.g. UPS, frequency drives, converter)

QUICK REFERENCE DATA		
Series	PhMKP..., cylindrical	PhMKPg..., cylindrical
Description	LVAC Power Capacitors - Oil - INDOOR , IP00 - IP20	LVAC Power Capacitors - Dry - INDOOR , IP00 - IP20
Type	Capacitors, fixed, low voltage	Capacitors, fixed, low voltage
Technology	MKP, metallized polypropylene film	MKP, metallized polypropylene film
Voltage max. (V)	1000	1000
Capacitance min. (μF)	3-phase D: 3 x 11.5, 3-phase Y: 3 x 83.6, 1-phase: 49.7	3-phase D: 3 x 11.5, 3-phase Y: 3 x 83.6
Capacitance max. (μF)	3-phase D: 3 x 335.0, 3-phase Y: 3 x 219.3, 1-phase: 332.2	3-phase D: 3 x 335.0, 3-phase Y: 3 x 219.3
Output min. (kvar)	2	2
Output max. (kvar)	37.1	37.1

CAPACITORS IN CYLINDRICAL CASING

APPLICATION

The Vishay ESTA PhMKP/PhMKPg series of power factor correction capacitors in cylindrical aluminum casing now provide higher kvar/voltage combinations for use in low-voltage systems.

The newly available 116 mm and 136 mm diameter capacitors complete the successful range of compact and slim cylindrical capacitors of 64 mm and 84.4 mm diameter design up to the lowest outputs of the triangular can design of the PhMKDg model.

The 116 mm and 136 mm start where the output of the 84 mm design ends. At the point of change, the customer has two options: the lower height profile of the 116 mm and 136 mm or the slimmer diameter of the 84.4 mm design.

The Vishay ESTA LVAC capacitors are suitable for use in both standard PFC applications and in heavy-duty applications such as wind turbines:

- automatic PFC-equipment
- individual fixed PFC (e.g. motors, transformers, lighting)
- group fixed PFC
- tuned and detuned capacitor banks
- harmonic filters (e.g. UPS, frequency drives, converter)

DESIGN

The Vishay ESTA LVAC MKP capacitors are metallized polypropylene film capacitors with self-healing properties. The current carrying metal layer of an MKP capacitor is vaporised onto one side of the polypropylene film. The front surface of tubular winding elements are joined by means of the metal spray method (schooping). Three winding elements are encapsulated in one aluminum casing and connected to form a true 3-phase capacitor. The overpressure tear-off fuse prevents the capacitor from bursting at the end of service life, or due to inadmissible electrical or thermal overloads.

The capacitor is housed in a tubular aluminum container with a aluminum lid press-rolled onto it (64 mm and 84.4 mm) or welded (116 mm and 136 mm). The current is supplied via IP00 screw-on (M5) or IP20 block type safety terminal. A threaded stud (M12) at the bottom of the container serves for both grounding and mounting.

The Vishay ESTAprop and ESTAdry capacitors will be delivered together with discharge resistors and hardware for mounting and connection.

Vishay ESTA standard capacitors of 64 mm, 84.4 mm, 116 mm and 136 mm diameter will be delivered together with a thickfilm discharge resistor unit and fixing material for easy mounting and connection. In 84.4 mm diameter IP00 design there is also an option for feed-through (IN-LINE) connection of the capacitors to the supply.

The entire range of Vishay ESTA LVAC products are offered in both natural oil-filled ESTAprop PhMKP and gas-filled ESTAdry PhMKPg versions.

1-/3-PHASE CAPACITOR, IP00 SCREW-TYPE TERMINALS 84.4 mm DIAMETER



1-/3-PHASE CAPACITOR, IP20 TERMINAL BLOCK 64 mm/84.4 mm DIAMETER



3-PHASE CAPACITOR, IP20 TERMINAL BLOCK 116 mm DIAMETER



3-PHASE CAPACITOR, IP20 TERMINAL BLOCK 136 mm DIAMETER



CAPACITORS IN CYLINDRICAL CASING

TECHNICAL DATA	
STANDARDS	IEC 60831-1 + 2, EN 60831- 1 + 2, UL810 LATEST EDITIONS, UL/ULC - FILE E97723
Overvoltages (in accordance with the above standards)	$U_{cn} + 10\%$ (up to 8 h daily) $U_{cn} + 15\%$ (up to 30 min daily) $U_{cn} + 20\%$ (up to 5 min, only 200 times in the life of the capacitor) $U_{cn} + 30\%$ (up to 1 min, only 200 times in the life of the capacitor) Please also refer to "Terms and Definitions".
Overcurrent (in accordance with the above standards)	$1.3 \times I_n$, $1.5 \times I_n$ with 10 % overvoltages, 15 % over capacitance and harmonics included, continuous operation Please also refer to "Terms and Definitions".
Tolerance on capacitance	- 5 %/+ 10 % in accordance with the standards ± 5 % as Vishay ESTA standard
Test voltage, terminal/terminal	$2.15 \times U_{cn}$, VAC, 2 s (routine test)
Test voltage, terminal/casing	4800 VAC, 2 s (routine test)
Inrush current	300 times rated current I_n
Losses	≤ 0.25 W/kvar to 0.45 W/kvar (without discharge resistors)
Statistical life expectancy	> 150 000 operating h (ESTAprop) > 130 000 operating h (ESTAdry)
Degree of protection	IP20 clamp terminal with mounted discharge resistor unit or IP00 (terminal cover for higher protection class upon request), indoor
Ambient temperature category	- 25/D (max. 55 °C) ESTAprop, - 40/D (max. 55 °C) ESTAdry
Permitted casing temperature	Max. 65 °C (measured on top of the can)
Cooling	Naturally air-cooled
Permissible relative humidity	Maximum 95 %
Maximum allowed altitude	2000 m above sea level
Mounting position	Vertical and horizontal
Mounting and grounding	Threaded M12 stud at the bottom of the container
Safety features	All-phase overpressure tear-off fuse, self-healing
Casing	Aluminum can
Dielectric	Polypropylene film, self-healing
Filling agent	Natural oil, non-PCB, biodegradable (ESTAprop) or dry/gas - filled (ESTAdry)
Terminals per casing Ø (cross-head screws)	Ø 64 mm IP20 M4 terminal block A (D-351), 3.0 Nm, max. 16 mm² drawing 1 max. current, depending on ambient conditions: 34 A (1-phase)/25 A (3-phase)
	Ø 84 mm IP00 M5 screw terminals (D-203), 2.0 Nm, max. 25 mm² drawing 2, feed through max. current, depending on ambient conditions: 57 A (1-phase)/52 A (3-phase)
	IP20 M4 terminal block A (D-351), 3.0 Nm, max. 16 mm² drawing 3 max. current, depending on ambient conditions: 57 A (1-phase)/52 A (3-phase)
	Ø 116 mm IP20 M5 terminal block B (D-352), 3.0 Nm, max. 25 mm² drawing 4 max. current, depending on ambient conditions: 60 A (3-phase)
	Ø 136 mm IP20 M5 terminal block B (D-352), 3.0 Nm, max. 25 mm² drawing 5 max. current, depending on ambient conditions: 60 A (3-phase)

3-PHASE CAPACITORS

IP00, OIL

RATED VOLTAGE 230 V, 50 Hz, DELTA CONNECTION, UL/ULC

TYPE	ARTICLE NO. ⁽¹⁾	OUTPUT kvar	CAP. μF	CURRENT A	DIMENSIONS Ø x H mm	WEIGHT kg	DRAWING NO.
PhMKP230.3.10,00-84-MH	5341-44400-xx	10	3 x 200.6	25.1	84.4 x 265	1.7	2
PhMKP230.3.12,50-84-MH	5341-44401-xx	12.5	3 x 250.7	31.4	84.4 x 340	2.0	2
PhMKP230.3.15,00-84-MH	5341-44402-xx	15	3 x 300.9	37.7	84.4 x 340	2.1	2

RATED VOLTAGE 400 V, 50 Hz, DELTA CONNECTION, UL/ULC

CAN BE USED ALSO FOR 415 V, FULL OVER VOLTAGE RANGE

TYPE	ARTICLE NO. ⁽¹⁾	OUTPUT kvar 400 V	OUTPUT kvar 415 V	CAP. μF	CURRENT A 400 V/415 V	DIMENSIONS Ø x H mm	WEIGHT kg	DRAWING NO.
PhMKP400.3.10,00-84-MH	5341-44403-xx	10	10.8	3 x 66.3	14.4/15.0	84.4 x 190	1.3	2
PhMKP400.3.12,50-84-MH	5341-44404-xx	12.5	13.5	3 x 82.9	18.0/18.7	84.4 x 190	1.3	2
PhMKP400.3.15,00-84-MH	5341-44405-xx	15	16.1	3 x 99.5	21.6/22.4	84.4 x 190	1.3	2
PhMKP400.3.16,70-84-MH	5341-44406-xx	16.7	18.0	3 x 110.7	24.1/25.0	84.4 x 265	1.7	2
PhMKP400.3.20,00-84-MH	5341-44407-xx	20	21.5	3 x 132.6	28.8/30.0	84.4 x 265	1.7	2
PhMKP400.3.25,00-84-MH	5341-44408-xx	25	26.9	3 x 165.8	36.1/37.4	84.4 x 265	1.7	2

RATED VOLTAGE 440 V, 50 Hz, DELTA CONNECTION, UL/ULC

CAN BE USED ALSO FOR 415 V

TYPE	ARTICLE NO. ⁽¹⁾	OUTPUT kvar 440 V	OUTPUT kvar 415 V	CAP. μF	CURRENT A 440 V/415 V	DIMENSIONS Ø x H mm	WEIGHT kg	DRAWING NO.
PhMKP440.3.12,50-84-MH	5341-44409-xx	12.5	11.1	3 x 68.5	16.4/15.5	84.4 x 190	1.3	2
PhMKP440.3.14,10-84-MH	5341-44410-xx	14.1	12.5	3 x 77.0	18.5/17.5	84.4 x 190	1.3	2
PhMKP440.3.15,00-84-MH	5341-44411-xx	15	13.3	3 x 82.2	19.7/18.6	84.4 x 190	1.3	2
PhMKP440.3.16,90-84-MH	5341-44412-xx	16.9	15	3 x 92.6	22.2/20.9	84.4 x 190	1.3	2
PhMKP440.3.18,80-84-MH	5341-44413-xx	18.8	16.7	3 x 103.0	24.7/23.3	84.4 x 265	1.7	2
PhMKP440.3.20,00-84-MH	5341-44414-xx	20	17.8	3 x 109.6	26.2/24.8	84.4 x 265	1.7	2
PhMKP440.3.22,50-84-MH	5341-44415-xx	22.5	20	3 x 123.3	29.5/27.8	84.4 x 265	1.7	2
PhMKP440.3.25,00-84-MH	5341-44416-xx	25	22.2	3 x 137.0	32.8/30.9	84.4 x 265	1.7	2
PhMKP440.3.28,10-84-MH	5341-44417-xx	28.1	25	3 x 154.0	36.9/34.8	84.4 x 265	1.7	2
PhMKP440.3.30,00-84-MH	5341-44418-xx	30	26.7	3 x 164.4	39.4/37.1	84.4 x 340	2.1	2

RATED VOLTAGE 525 V, 50 Hz, DELTA CONNECTION, UL/ULC

CAN BE USED ALSO FOR 480 V

TYPE	ARTICLE NO. ⁽¹⁾	OUTPUT kvar 525 V	OUTPUT kvar 480 V	CAP. μF	CURRENT A 525 V/480 V	DIMENSIONS Ø x H mm	WEIGHT kg	DRAWING NO.
PhMKP525.3.10,00-84-MH	5341-44419-xx	10	8.33	3 x 38.5	11.0/10.1	84.4 x 190	1.3	2
PhMKP525.3.12,50-84-MH	5341-44420-xx	12.5	10.4	3 x 48.1	13.7/12.6	84.4 x 190	1.3	2
PhMKP525.3.13,80-84-MH	5341-44421-xx	13.8	11.5	3 x 53.1	15.2/13.8	84.4 x 190	1.3	2
PhMKP525.3.15,00-84-MH	5341-44422-xx	15	12.5	3 x 57.7	16.5/15.0	84.4 x 190	1.3	2
PhMKP525.3.20,00-84-MH	5341-44423-xx	20	16.7	3 x 77.0	22.0/20.1	84.4 x 265	1.7	2
PhMKP525.3.25,00-84-MH	5341-44424-xx	25	20	3 x 96.2	27.5/24.6	84.4 x 265	1.7	2

Notes

- Other voltage ratings, outputs, and frequencies upon request. All PhMKP-type capacitors may be also be applied in 60 Hz networks, output and current will, however, be 20 % higher in these cases (i.e. additional thermal load and therefore, a lower class of temperature must be taken into account)

⁽¹⁾ Version no. xx may differ as it respects small changes, e.g. on the label

RATED VOLTAGE 660 V, 50 Hz, DELTA CONNECTION, UL/ULC UP TO 660 V								
CAN BE USED ALSO FOR 690 V, FULL OVER VOLTAGE RANGE								
TYPE	ARTICLE NO. ⁽¹⁾	OUTPUT kvar 660 V	OUTPUT kvar 690 V	CAP. μ F	CURRENT A 660 V/690 V	DIMENSIONS \varnothing x H mm	WEIGHT kg	DRAWING NO.
PhMKP660.3.08,33-84-MH	5341-44425-xx	8.33	9.1	3 x 20.3	7.3/7.6	84.4 x 190	1.4	2
PhMKP660.3.10,00-84-MH	5341-44426-xx	10	10.9	3 x 24.4	8.7/9.1	84.4 x 190	1.9	2
PhMKP660.3.12,50-84-MH	5341-44427-xx	12.5	13.7	3 x 30.4	10.9/11.5	84.4 x 265	1.9	2
PhMKP660.3.15,00-84-MH	5341-44428-xx	15	16.4	3 x 36.5	13.1/13.7	84.4 x 265	2.0	2
PhMKP660.3.16,70-84-MH	5341-44429-xx	16.7	18.3	3 x 40.7	14.6/15.3	84.4 x 265	2.0	2
PhMKP660.3.20,00-84-MH	5341-44430-xx	20	21.9	3 x 48.7	17.5/18.3	84.4 x 340	2.4	2
PhMKP660.3.22,90-84-MH	5341-44431-xx	22.9	25.0	3 x 55.8	20.0/20.9	84.4 x 340	2.4	2

RATED VOLTAGE 690 V, 50 Hz, DELTA CONNECTION								
CAN BE USED ALSO FOR 660 V								
TYPE	ARTICLE NO. ⁽¹⁾	OUTPUT kvar 660 V	OUTPUT kvar 690 V	CAP. μ F	CURRENT A 690 V/660 V	DIMENSIONS \varnothing x H mm	WEIGHT kg	DRAWING NO.
PhMKP690.3.12,50-84-MH	5341-44432-xx	11.4	12.5	3 x 27.9	10.5/10.0	84.4 x 265	1.9	2
PhMKP690.3.15,00-84-MH	5341-44433-xx	13.7	15	3 x 33.4	12.6/12.0	84.4 x 265	1.9	2
PhMKP690.3.20,00-84-MH	5341-44434-xx	18.3	20	3 x 44.6	16.7/16.0	84.4 x 340	2.4	2
PhMKP690.3.25,00-84-MH	5341-44435-xx	22.9	25	3 x 55.8	20.9/20.0	84.4 x 340	2.4	2

Notes

- Other voltage ratings, outputs, and frequencies upon request. All PhMKP-type capacitors may be also applied in 60 Hz networks, output and current will, however, be 20 % higher in these cases (i.e. additional thermal load and therefore, a lower class of temperature must be taken into account)

⁽¹⁾ Version no. xx may differ as it respects small changes, e.g. on the label

**Terminal cover (IP20), available for 84.4 mm diameter tubular can type capacitors.
(Cable gland not available for use with these covers)**

TYPE	ARTICLE NO.	CAPACITOR \varnothing IN mm
CAP84-88-IN-LINE-MH	5341-COV-84-88-IP20-7	88.2

Type CAP84-88-IN-LINE-MH

- Protection class IP20
- Protective cover prevents unintentional touching of live terminals
- Proper ventilation is provided by use of additional holes in the protective cover's top
- Six slots located on the cover, three on each side, allow easy IN-LINE connection between two

TERMINAL COVER IP20: CAP84-IN-LINE-MH



IN-LINE CONNECTION BETWEEN TWO CAPACITORS, IP20



3-PHASE CAPACITORS

IP20, OIL

RATED VOLTAGE 230 V, 50 Hz, DELTA CONNECTION, UL/ULC							
TYPE	ARTICLE NO. ⁽¹⁾	OUTPUT kvar	CAP. μ F	CURRENT A	DIMENSIONS \varnothing x H mm	WEIGHT kg	DRAWING NO.
PhMKP230.3.02,50-A64-MH	5341-48300-xx	2.5	3 x 50.1	6.3	64 x 190	0.8	1
PhMKP230.3.05,00-A64-MH	5341-48301-xx	5	3 x 100.3	12.6	64 x 265	1.0	1
PhMKP230.3.10,00-A84-MH	5341-48600-xx	10	3 x 200.6	25.1	84.4 x 265	1.7	3
PhMKP230.3.12,50-A84-MH	5341-48601-xx	12.5	3 x 250.7	31.4	84.4 x 340	2.0	3
PhMKP230.3.15,00-A84-MH	5341-48602-xx	15	3 x 300.9	37.7	84.4 x 340	2.1	3
PhMKP230.3.10,00-B116-MH	5341-47003-xx	10	3 x 200.6	25.1	116 x 160	2.1	4
PhMKP230.3.12,50-B116-MH	5341-47004-xx	12.5	3 x 250.7	31.4	116 x 190	2.5	4
PhMKP230.3.15,00-B116-MH	5341-47005-xx	15	3 x 300.9	37.7	116 x 190	2.5	4
PhMKP230.3.16,70-B116-MH	5341-47006-xx	16.7	3 x 335.0	41.9	116 x 230	3.1	4

RATED VOLTAGE 400 V, 50 Hz, DELTA CONNECTION, UL/ULC								
CAN BE USED ALSO FOR 415 V, FULL OVER VOLTAGE RANGE								
TYPE	ARTICLE NO. ⁽¹⁾	OUTPUT kvar 400 V	OUTPUT kvar 415 V	CAP. μ F	CURRENT A 400 V/415 V	DIMENSIONS \varnothing x H mm	WEIGHT kg	DRAWING NO.
PhMKP400.3.02,50-A64-MH	5341-48302-xx	2.5	2.7	3 x 16.6	3.6/3.7	64 x 190	0.8	1
PhMKP400.3.05,00-A64-MH	5341-48303-xx	5	5.4	3 x 33.2	7.2/7.5	64 x 190	0.8	1
PhMKP400.3.06,67-A64-MH	5341-48304-xx	6.67	7.2	3 x 44.2	9.6/10.0	64 x 190	0.8	1
PhMKP400.3.07,50-A64-MH	5341-48305-xx	7.5	8.1	3 x 49.7	10.8/11.2	64 x 190	0.8	1
PhMKP400.3.08,33-A64-MH	5341-48306-xx	8.33	9.0	3 x 55.2	12/12.5	64 x 190	0.8	1
PhMKP400.3.10,00-A64-MH	5341-48307-xx	10	10.8	3 x 66.3	14.4/14.9	64 x 265	1.0	1
PhMKP400.3.12,50-A64-MH	5341-48308-xx	12.5	13.5	3 x 82.9	18/18.7	64 x 265	1.0	1
PhMKP400.3.10,00-A84-MH	5341-48603-xx	10	10.8	3 x 66.3	14.4/14.9	84.4 x 190	1.3	3
PhMKP400.3.12,50-A84-MH	5341-48604-xx	12.5	13.5	3 x 82.9	18/18.7	84.4 x 190	1.3	3
PhMKP400.3.15,00-A84-MH	5341-48605-xx	15	16.1	3 x 99.5	21.6/22.4	84.4 x 190	1.3	3
PhMKP400.3.16,70-A84-MH	5341-48606-xx	16.7	18.0	3 x 110.7	24.1/25.0	84.4 x 265	1.7	3
PhMKP400.3.20,00-A84-MH	5341-48607-xx	20	21.5	3 x 132.6	28.8/30.0	84.4 x 265	1.7	3
PhMKP400.3.25,00-A84-MH	5341-48608-xx	25	26.9	3 x 165.8	36.1/37.4	84.4 x 265	1.7	3
PhMKP400.3.16,70-B116-MH	5341-47010-xx	16.7	18.0	3 x 110.7	24.1/25.0	116 x 160	2.1	4
PhMKP400.3.20,00-B116-MH	5341-47011-xx	20	21.5	3 x 132.6	28.8/29.9	116 x 160	2.1	4
PhMKP400.3.25,00-B116-MH	5341-47012-xx	25	26.9	3 x 165.8	36.1/37.4	116 x 190	2.5	4
PhMKP400.3.30,00-B136-MH	5341-47601-xx	30	32.3	3 x 198.9	43.3/44.9	136 x 190	2.6	5

Notes

- Other voltage ratings, outputs, and frequencies upon request. All PhMKP-type capacitors may be also be applied in 60 Hz networks, output and current will, however, be 20 % higher in these cases (i.e. additional thermal load and therefore, a lower class of temperature must be taken into account)

⁽¹⁾ Version no. xx may differ as it respects small changes, e.g. on the label

RATED VOLTAGE 440 V, 50 Hz, DELTA CONNECTION, UL/ULC								
CAN BE USED ALSO FOR 415 V								
TYPE	ARTICLE NO. ⁽¹⁾	OUTPUT kvar 440 V	OUTPUT kvar 415 V	CAP. μF	CURRENT A 440 V/415 V	DIMENSIONS \varnothing x H mm	WEIGHT kg	DRAWING NO.
PhMKP440.3.02,50-A64-MH	5341-48322-xx	2.5	2.2	3 x 13.7	3.3/3.1	64 x 190	0.7	1
PhMKP440.3.05,00-A64-MH	5341-48309-xx	5	4.4	3 x 27.4	6.6/6.1	64 x 190	0.8	1
PhMKP440.3.08,33-A64-MH	5341-48310-xx	8.33	7.4	3 x 45.7	10.9/10.3	64 x 190	0.8	1
PhMKP440.3.10,00-A64-MH	5341-48311-xx	10	8.9	3 x 54.8	13.1/12.4	64 x 265	1.0	1
PhMKP440.3.11,20-A64-MH	5341-48312-xx	11.2	10	3 x 61.4	14.7/13.9	64 x 265	1.0	1
PhMKP440.3.12,50-A64-MH	5341-48313-xx	12.5	11.1	3 x 68.5	16.4/15.4	64 x 265	1.0	1
PhMKP440.3.14,00-A64-MH	5341-48314-xx	14	12.5	3 x 76.7	18.4/17.4	64 x 265	1.0	1
PhMKP440.3.12,50-A84-MH	5341-48609-xx	12.5	11.1	3 x 68.5	16.4/15.5	84.4 x 190	1.3	3
PhMKP440.3.14,10-A84-MH	5341-48610-xx	14.1	12.5	3 x 77.0	18.5/17.5	84.4 x 190	1.3	3
PhMKP440.3.15,00-A84-MH	5341-48611-xx	15	13.3	3 x 82.2	19.7/18.6	84.4 x 190	1.3	3
PhMKP440.3.16,90-A84-MH	5341-48612-xx	16.9	15	3 x 92.6	22.2/20.9	84.4 x 190	1.3	3
PhMKP440.3.18,80-A84-MH	5341-48613-xx	18.8	16.67	3 x 103.0	24.7/23.3	84.4 x 265	1.7	3
PhMKP440.3.20,00-A84-MH	5341-48614-xx	20	17.8	3 x 109.6	26.2/24.8	84.4 x 265	1.7	3
PhMKP440.3.22,50-A84-MH	5341-48615-xx	22.5	20	3 x 123.3	29.5/27.8	84.4 x 265	1.7	3
PhMKP440.3.25,00-A84-MH	5341-48616-xx	25	22.2	3 x 137.0	32.8/30.9	84.4 x 265	1.7	3
PhMKP440.3.28,10-A84-MH	5341-48617-xx	28.1	25	3 x 154.0	36.9/34.8	84.4 x 265	1.7	3
PhMKP440.3.30,00-A84-MH	5341-48618-xx	30	26.7	3 x 164.4	39.4/37.1	84.4 x 340	2.1	3
PhMKP440.3.14,10-B116-MH	5341-47068-xx	14.1	12.5	3 x 77.0	18.5/17.5	116 x 160	1.5	4
PhMKP440.3.18,80-B116-MH	5341-47015-xx	18.8	16.67	3 x 103.0	24.7/23.3	116 x 160	1.8	4
PhMKP440.3.20,00-B116-MH	5341-47016-xx	20	17.8	3 x 109.6	26.2/24.8	116 x 160	1.8	4
PhMKP440.3.22,50-B116-MH	5341-47017-xx	22.5	20	3 x 123.3	29.5/27.8	116 x 160	1.9	4
PhMKP440.3.25,00-B116-MH	5341-47018-xx	25	22.2	3 x 137.0	32.8/30.9	116 x 190	2.0	4
PhMKP440.3.28,10-B116-MH	5341-47020-xx	28.1	25	3 x 154.0	36.9/34.8	116 x 190	2.0	4
PhMKP440.3.30,00-B116-MH	5341-47022-xx	30	26.7	3 x 164.4	39.4/37.1	116 x 190	2.2	4
PhMKP440.3.33,00-B136-MH	5341-47602-xx	33	29.4	3 x 180.9	43.3/40.9	136 x 190	2.3	5

Notes

- Other voltage ratings, outputs, and frequencies upon request. All PhMKP-type capacitors may be also be applied in 60 Hz networks, output and current will, however, be 20 % higher in these cases (i.e. additional thermal load and therefore, a lower class of temperature must be taken into account)

⁽¹⁾ Version no. xx may differ as it respects small changes, e.g. on the label

RATED VOLTAGE 525 V, 50 Hz, DELTA CONNECTION, UL/ULC								
CAN BE USED ALSO FOR 480 V								
TYPE	ARTICLE NO. ⁽¹⁾	OUTPUT kvar 525 V	OUTPUT kvar 480 V	CAP. μF	CURRENT A 525 V/480 V	DIMENSIONS Ø x H mm	WEIGHT kg	DRAWING NO.
PhMKP525.3.03,00-A64-MH	5341-48315-xx	3	2.5	3 x 11.5	3.3/3.0	64 x 190	0.8	1
PhMKP525.3.05,00-A64-MH	5341-48316-xx	5	4.2	3 x 19.2	5.5/5.0	64 x 190	0.8	1
PhMKP525.3.08,33-A64-MH	5341-48317-xx	8.33	7	3 x 32.1	9.2/8.4	64 x 190	0.8	1
PhMKP525.3.10,00-A64-MH	5341-48318-xx	10	8.33	3 x 38.5	11.0/10.1	64 x 265	1.0	1
PhMKP525.3.10,00-A84-MH	5341-48619-xx	10	8.33	3 x 38.5	11.0/10.1	84.4 x 190	1.3	3
PhMKP525.3.12,50-A84-MH	5341-48620-xx	12.5	10.4	3 x 48.1	13.7/12.6	84.4 x 190	1.3	3
PhMKP525.3.13.80-A84-MH	5341-48621-xx	13.8	11.5	3 x 53.1	15.2/13.8	84.4 x 190	1.3	3
PhMKP525.3.15,00-A84-MH	5341-48622-xx	15	12.5	3 x 57.7	16.5/15.0	84.4 x 190	1.3	3
PhMKP525.3.20,00-A84-MH	5341-48623-xx	20	16.7	3 x 77.0	22.0/20.1	84.4 x 265	1.7	3
PhMKP525.3.25,00-A84-MH	5341-48624-xx	25	20.9	3 x 96.2	27.5/24.6	84.4 x 265	1.7	3
PhMKP525.3.20,00-B116-MH	5341-47024-xx	20	16.7	3 x 77.0	22.0/20.1	116 x 160	1.8	4
PhMKP525.3.25,00-B116-MH	5341-47025-xx	25	20.9	3 x 96.2	27.5/25.1	116 x 190	2.5	4
PhMKP525.3.30,00-B116-MH	5341-47069-xx	30	25.1	3 x 115.4	33.0/30.2	116 x 230	2.6	4
PhMKP525.3.30,00-B136-MH	5341-47603-xx	30	25.1	3 x 115.4	33.0/30.2	136 x 190	2.6	5
PhMKP525.3.35,90-B116-MH	5341-47070-xx	35.9	30	3 x 138.2	39.5/36.1	116 x 265	2.8	4
PhMKP525.3.35,90-B136-MH	5341-47600-xx	35.9	30	3 x 138.2	39.5/36.1	136 x 230	3.5	5
PhMKP525.3.37,10-B116-MH	5341-47065-xx	37.1	31	3 x 142.8	40.8/37.3	116 x 265	2.8	4
PhMKP525.3.37,10-B136-MH	5341-47604-xx	37.1	31	3 x 142.8	40.8/37.3	136 x 230	3.5	5

Notes

- Other voltage ratings, outputs, and frequencies upon request. All PhMKP-type capacitors may be also be applied in 60 Hz networks, output and current will, however, be 20 % higher in these cases (i.e. additional thermal load and therefore, a lower class of temperature must be taken into account)

⁽¹⁾ Version no. xx may differ as it respects small changes, e.g. on the label

RATED VOLTAGE 660 V, 50 Hz, 64/84: DELTA CONNECTION, 116/136: STAR CONNECTION, UL/ULC UP TO 660 V

CAN BE USED ALSO FOR 690 V

TYPE	ARTICLE NO. (1)	OUTPUT kvar 660 V	OUTPUT kvar 690 V	CAP. μ F	CURRENT A 660 V/690 V	DIMENSIONS \varnothing x H mm	WEIGHT kg	DRAWING NO.
PhMKP660.3.05,00-A64-MH	5341-48319-xx	5	5.5	3 x 12.2	4.4/4.6	64 x 190	0.8	1
PhMKP660.3.08,33-A64-MH	5341-48320-xx	8.33	9.1	3 x 20.3	7.3/7.6	64 x 265	1.0	1
PhMKP660.3.08,33-A84-MH	5341-48625-xx	8.33	9.1	3 x 20.3	7.3/7.6	84.4 x 190	1.3	3
PhMKP660.3.10,00-A84-MH	5341-48626-xx	10	10.9	3 x 24.4	8.7/9.1	84.4 x 190	1.3	3
PhMKP660.3.12,50-A84-MH	5341-48627-xx	12.5	13.7	3 x 30.4	10.9/11.4	84.4 x 265	1.7	3
PhMKP660.3.15,00-A84-MH	5341-48628-xx	15	16.4	3 x 36.5	13.1/13.7	84.4 x 265	1.7	3
PhMKP660.3.16,70-A84-MH	5341-48629-xx	16.7	18.3	3 x 40.7	14.6/15.3	84.4 x 265	1.7	3
PhMKP660.3.20,00-A84-MH	5341-48630-xx	20	21.9	3 x 48.7	17.5/18.3	84.4 x 340	2.1	3
PhMKP660.3.22,90-A84-MH	5341-48631-xx	22.9	25	3 x 55.8	20/20.9	84.4 x 340	2.1	3
PhMKP660.2.12,50-B116-MH	5341-47057-xx	12.5	13.7	3 x 91.4	10.9/11.4	116 x 160	2.1	4
PhMKP660.2.15,00-B116-MH	5341-47058-xx	15	16.4	3 x 109.6	13.1/13.7	116 x 160	2.1	4
PhMKP660.2.16,70-B116-MH	5341-47059-xx	16.7	18.3	3 x 122.1	14.6/15.3	116 x 160	2.1	4
PhMKP660.2.20,00-B116-MH	5341-47061-xx	20	21.9	3 x 146.2	17.5/18.3	116 x 190	2.3	4
PhMKP660.2.22,90-B116-MH	5341-47062-xx	22.9	25	3 x 167.3	20/20.9	116 x 190	2.5	4
PhMKP660.2.25,00-B136-MH	5341-47605-xx	25	27.3	3 x 182.6	21.9/22.9	136 x 190	2.6	5
PhMKP660.2.30,00-B136-MH	5341-47606-xx	30	32.8	3 x 219.3	26.2/27.4	136 x 230	3.0	5

RATED VOLTAGE 690 V, 50 Hz, 64/84: DELTA CONNECTION, 116/136: STAR CONNECTION

CAN BE USED ALSO FOR 660 V

TYPE	ARTICLE NO. (1)	OUTPUT kvar 690 V	OUTPUT kvar 660 V	CAP. μ F	CURRENT A 690 V/660 V	DIMENSIONS \varnothing x H mm	WEIGHT kg	DRAWING NO.
PhMKP690.3.10,00-A64-MH	5341-48321-xx	10	9.1	3 x 22.3	8.4/8.0	64 x 265	1.1	1
PhMKP690.3.12,50-A84-MH	5341-48632-xx	12.5	11.4	3 x 27.9	10.5/10.0	84.4 x 265	1.9	3
PhMKP690.3.15,00-A84-MH	5341-48633-xx	15	13.7	3 x 33.4	12.5/12.0	84.4 x 265	1.9	3
PhMKP690.3.20,00-A84-MH	5341-48634-xx	20	18.3	3 x 44.6	16.7/16.0	84.4 x 340	2.4	3
PhMKP690.3.25,00-A84-MH	5341-48635-xx	25	22.9	3 x 55.7	20.9/20.0	84.4 x 340	2.4	3
PhMKP690.2.12,50-B116-MH	5341-47071-xx	12.5	11.4	3 x 83.6	10.5/10.0	116 x 160	2.0	4
PhMKP690.2.15,00-B116-MH	5341-47072-xx	15	13.7	3 x 100.3	12.5/12.0	116 x 160	2.2	4
PhMKP690.2.20,00-B116-MH	5341-47073-xx	20	18.3	3 x 133.7	16.7/16.0	116 x 190	2.2	4
PhMKP690.2.25,00-B116-MH	5341-47074-xx	25	22.9	3 x 167.3	20.9/20.0	116 x 190	2.5	4

Notes

- Other voltage ratings, outputs, and frequencies upon request. All PhMKP-type capacitors may be also be applied in 60 Hz networks, output and current will, however, be 20 % higher in these cases (i.e. additional thermal load and therefore, a lower class of temperature must be taken into account)

(1) Version no. xx may differ as it respects small changes, e.g. on the label

RATED VOLTAGE 230 V, 50 Hz, DELTA CONNECTION, UL/ULC

TYPE	ARTICLE NO. ⁽¹⁾	OUTPUT kvar	CAP. μ F	CURRENT A	DIMENSIONS \varnothing x H mm	WEIGHT kg	DRAWING NO.
PhMKPg230.3.10,00-84-MH	5343-44001-xx	10	3 x 200.6	25.1	84.4 x 265	1.4	2
PhMKPg230.3.12,50-84-MH	5343-44002-xx	12.5	3 x 250.7	31.4	84.4 x 340	1.5	2
PhMKPg230.3.15,00-84-MH	5343-44003-xx	15	3 x 300.9	37.7	84.4 x 340	1.7	2

RATED VOLTAGE 400 V, 50 Hz, DELTA CONNECTION, UL/ULC

CAN BE USED ALSO FOR 415 V, FULL OVER VOLTAGE RANGE

TYPE	ARTICLE NO. ⁽¹⁾	OUTPUT kvar 400 V	OUTPUT kvar 415 V	CAP. μ F	CURRENT A 400 V/415 V	DIMENSIONS \varnothing x H mm	WEIGHT kg	DRAWING NO.
PhMKPg400.3.10,00-84-MH	5343-44004-xx	10	10.8	3 x 66.3	14.4/15.0	84.4 x 190	0.9	2
PhMKPg400.3.12,50-84-MH	5343-44005-xx	12.5	13.5	3 x 82.9	18.0/18.7	84.4 x 190	1.0	2
PhMKPg400.3.15,00-84-MH	5343-44006-xx	15	16.1	3 x 99.5	21.6/22.4	84.4 x 190	1.1	2
PhMKPg400.3.16,70-84-MH	5343-44007-xx	16.7	18.0	3 x 110.7	24.1/25.0	84.4 x 265	1.4	2
PhMKPg400.3.20,00-84-MH	5343-44008-xx	20	21.5	3 x 132.6	28.8/30.0	84.4 x 265	1.4	2
PhMKPg400.3.25,00-84-MH	5343-44009-xx	25	26.9	3 x 165.8	36.1/37.4	84.4 x 265	1.5	2

RATED VOLTAGE 440 V, 50 Hz, DELTA CONNECTION, UL/ULC

CAN BE USED ALSO FOR 415 V

TYPE	ARTICLE NO. ⁽¹⁾	OUTPUT kvar 440 V	OUTPUT kvar 415 V	CAP. μ F	CURRENT A 440 V/415 V	DIMENSIONS \varnothing x H mm	WEIGHT kg	DRAWING NO.
PhMKPg440.3.12,50-84-MH	5343-44010-xx	12.5	11.1	3 x 68.5	16.4/15.5	84.4 x 190	1.0	2
PhMKPg440.3.14,10-84-MH	5343-44011-xx	14.1	12.5	3 x 77.0	18.5/17.5	84.4 x 190	1.1	2
PhMKPg440.3.15,00-84-MH	5343-44012-xx	15	13.3	3 x 82.2	19.7/18.6	84.4 x 190	1.1	2
PhMKPg440.3.16,90-84-MH	5343-44013-xx	16.9	15	3 x 92.6	22.2/20.9	84.4 x 190	1.2	2
PhMKPg440.3.18,80-84-MH	5343-44014-xx	18.8	16.7	3 x 103.0	24.7/23.3	84.4 x 265	1.3	2
PhMKPg440.3.20,00-84-MH	5343-44015-xx	20	17.8	3 x 109.6	26.2/24.8	84.4 x 265	1.4	2
PhMKPg440.3.22,50-84-MH	5343-44016-xx	22.5	20	3 x 123.3	29.5/27.8	84.4 x 265	1.4	2
PhMKPg440.3.25,00-84-MH	5343-44017-xx	25	22.2	3 x 137.0	32.8/30.9	84.4 x 265	1.5	2
PhMKPg440.3.28,10-84-MH	5343-44018-xx	28.1	25	3 x 154.0	36.9/34.8	84.4 x 265	1.5	2
PhMKPg440.3.30,00-84-MH	5343-44019-xx	30	26.7	3 x 164.4	39.4/37.1	84.4 x 340	1.8	2

RATED VOLTAGE 525 V, 50 Hz, DELTA CONNECTION, UL/ULC

CAN BE USED ALSO FOR 480 V

TYPE	ARTICLE NO. ⁽¹⁾	OUTPUT kvar 525 V	OUTPUT kvar 480 V	CAP. μ F	CURRENT A 525 V/480 V	DIMENSIONS \varnothing x H mm	WEIGHT kg	DRAWING NO.
PhMKPg525.3.10,00-84-MH	5343-44020-xx	10	8.33	3 x 38.5	11.0/10.1	84.4 x 190	0.8	2
PhMKPg525.3.12,50-84-MH	5343-44021-xx	12.5	10.4	3 x 48.1	13.7/12.6	84.4 x 190	1.0	2
PhMKPg525.3.13,80-84-MH	5343-44022-xx	13.8	11.5	3 x 53.1	15.2/13.8	84.4 x 190	1.0	2
PhMKPg525.3.15,00-84-MH	5343-44023-xx	15	12.5	3 x 57.7	16.5/15.0	84.4 x 190	1.1	2
PhMKPg525.3.20,00-84-MH	5343-44024-xx	20	16.7	3 x 77.0	22.0/20.1	84.4 x 265	1.3	2
PhMKPg525.3.25,00-84-MH	5343-44025-xx	25	20	3 x 96.2	27.5/24.6	84.4 x 265	1.5	2

Notes

- Other voltage ratings, outputs, and frequencies upon request. All PhMKPg-type capacitors may be also be applied in 60 Hz networks, output and current will, however, be 20 % higher in these cases (i.e. additional thermal load and therefore, a lower class of temperature must be taken into account)

⁽¹⁾ Version no. xx may differ as it respects small changes, e.g. on the label

RATED VOLTAGE 660 V, 50 Hz, DELTA CONNECTION, UL/ULC UP TO 660 V								
CAN BE USED ALSO FOR 690 V, FULL OVER VOLTAGE RANGE								
TYPE	ARTICLE NO. ⁽¹⁾	OUTPUT kvar 660 V	OUTPUT kvar 690 V	CAP. μF	CURRENT A 660 V/690 V	DIMENSIONS Ø x H mm	WEIGHT kg	DRAWING NO.
PhMKPg660.3.08,33-84-MH	5343-44026-xx	8.33	9.1	3 x 20.3	7.3/7.6	84.4 x 190	0.9	2
PhMKPg660.3.10,00-84-MH	5343-44027-xx	10	10.9	3 x 24.4	8.7/9.1	84.4 x 190	1.1	2
PhMKPg660.3.12,50-84-MH	5343-44028-xx	12.5	13.7	3 x 30.4	10.9/11.5	84.4 x 265	1.2	2
PhMKPg660.3.15,00-84-MH	5343-44029-xx	15	16.4	3 x 36.5	13.1/13.7	84.4 x 265	1.4	2
PhMKPg660.3.16,70-84-MH	5343-44030-xx	16.7	18.3	3 x 40.7	14.6/15.3	84.4 x 265	1.5	2
PhMKPg660.3.20,00-84-MH	5343-44031-xx	20	21.9	3 x 48.7	17.5/18.3	84.4 x 340	1.7	2
PhMKPg660.3.22,90-84-MH	5343-44032-xx	22.9	25.0	3 x 55.8	20.0/20.9	84.4 x 340	1.9	2

RATED VOLTAGE 690 V, 50 Hz, DELTA CONNECTION								
CAN BE USED ALSO FOR 660 V								
TYPE	ARTICLE NO. ⁽¹⁾	OUTPUT kvar 660 V	OUTPUT kvar 690 V	CAP. μF	CURRENT A 690 V/660 V	DIMENSIONS Ø x H mm	WEIGHT kg	DRAWING NO.
PhMKPg690.3.12,50-84-MH	5343-44033-xx	11.4	12.5	3 x 27.9	10.5/10.0	84.4 x 265	1.1	2
PhMKPg690.3.15,00-84-MH	5343-44034-xx	13.7	15	3 x 33.4	12.6/12.0	84.4 x 265	1.3	2
PhMKPg690.3.20,00-84-MH	5343-44035-xx	18.3	20	3 x 44.6	16.7/16.0	84.4 x 340	1.6	2
PhMKPg690.3.25,00-84-MH	5343-44036-xx	22.9	25	3 x 55.8	20.9/20.0	84.4 x 340	1.9	2

Notes

- Other voltage ratings, outputs, and frequencies upon request. All PhMKP-type capacitors may be also be applied in 60 Hz networks, output and current will, however, be 20 % higher in these cases (i.e. additional thermal load and therefore, a lower class of temperature must be taken into account)

⁽¹⁾ Version no. xx may differ as it respects small changes, e.g. on the label

**Terminal cover (IP20), available for 84.4 mm diameter tubular can type capacitors.
(Cable gland not available for use with these covers)**

TYPE	ARTICLE NO.	CAPACITOR Ø IN mm
CAP84-88-IN-LINE-MH	5341-COV-84-88-IP20-7	88.2

Type CAP84-88-IN-LINE-MH

- Protection class IP20
- Protective cover prevents unintentional touching of live terminals
- Proper ventilation is provided by use of additional holes in the protective cover's top
- Six slots located on the cover, three on each side, allow easy IN-LINE connection between two

TERMINAL COVER IP20: CAP84-IN-LINE



IN-LINE CONNECTION BETWEEN TWO CAPACITORS, IP20



RATED VOLTAGE 230 V, 50 Hz, DELTA CONNECTION, UL/ULC

TYPE	ARTICLE NO. ⁽¹⁾	OUTPUT kvar	CAP. μF	CURRENT A	DIMENSIONS Ø x H mm	WEIGHT kg	DRAWING NO.
PhMKPg230.3.02,50-A64-MH	5343-48200-xx	2.5	3 x 50.1	6.3	64 x 190	0.6	1
PhMKPg230.3.05,00-A64-MH	5343-48201-xx	5	3 x 100.3	12.6	64 x 265	0.8	1
PhMKPg230.3.10,00-A84-MH	5343-48500-xx	10	3 x 200.6	25.1	84.4 x 265	1.4	3
PhMKPg230.3.12,50-A84-MH	5343-48501-xx	12.5	3 x 250.7	31.4	84.4 x 340	1.5	3
PhMKPg230.3.15,00-A84-MH	5343-48502-xx	15	3 x 300.9	37.7	84.4 x 340	1.7	3
PhMKPg230.3.10,00-B116-MH	5343-47206-xx	10	3 x 200.6	25.1	116 x 160	1.5	4
PhMKPg230.3.12,50-B116-MH	5343-47207-xx	12.5	3 x 250.7	31.4	116 x 190	1.7	4
PhMKPg230.3.15,00-B116-MH	5343-47208-xx	15	3 x 300.9	37.7	116 x 190	1.9	4
PhMKPg230.3.16,70-B116-MH	5343-47209-xx	16.7	3 x 335.0	41.9	116 x 230	2.2	4

RATED VOLTAGE 400 V, 50 Hz, DELTA CONNECTION, UL/ULC

CAN BE USED ALSO FOR 415 V, FULL OVER VOLTAGE RANGE

TYPE	ARTICLE NO. ⁽¹⁾	OUTPUT kvar 400 V	OUTPUT kvar 415 V	CAP. μF	CURRENT A 400 V/415 V	DIMENSIONS Ø x H mm	WEIGHT kg	DRAWING NO.
PhMKPg400.3.02,50-A64-MH	5343-48202-xx	2.5	2.7	3 x 16.6	3.6/3.7	64 x 190	0.6	1
PhMKPg400.3.05,00-A64-MH	5343-48203-xx	5	5.4	3 x 33.2	7.2/7.5	64 x 190	0.6	1
PhMKPg400.3.06,67-A64-MH	5343-48204-xx	6.67	7.2	3 x 44.2	9.6/10.0	64 x 190	0.6	1
PhMKPg400.3.07,50-A64-MH	5343-48205-xx	7.5	8.1	3 x 49.7	10.8/11.2	64 x 190	0.6	1
PhMKPg400.3.08,33-A64-MH	5343-48206-xx	8.33	9.0	3 x 55.2	12/12.5	64 x 190	0.7	1
PhMKPg400.3.10,00-A64-MH	5343-48207-xx	10	10.8	3 x 66.3	14.4/14.9	64 x 265	0.7	1
PhMKPg400.3.12,50-A64-MH	5343-48208-xx	12.5	13.5	3 x 82.9	18/18.7	64 x 265	0.8	1
PhMKPg400.3.10,00-A84-MH	5343-48503-xx	10	10.8	3 x 66.3	14.4/14.9	84.4 x 190	1.0	3
PhMKPg400.3.12,50-A84-MH	5343-48504-xx	12.5	13.5	3 x 82.9	18/18.7	84.4 x 190	1.4	3
PhMKPg400.3.15,00-A84-MH	5343-48505-xx	15	16.1	3 x 99.5	21.6/22.4	84.4 x 190	1.4	3
PhMKPg400.3.16,70-A84-MH	5343-48506-xx	16.7	18.0	3 x 110.7	24.1/25.0	84.4 x 265	1.4	3
PhMKPg400.3.20,00-A84-MH	5343-48507-xx	20	21.5	3 x 132.6	28.8/30.0	84.4 x 265	1.4	3
PhMKPg400.3.25,00-A84-MH	5343-48508-xx	25	26.9	3 x 165.8	36.1/37.4	84.4 x 265	1.5	3
PhMKPg400.3.16,70-B116-MH	5343-47212-xx	16.7	18.0	3 x 110.7	24.1/25.0	116 x 160	1.5	4
PhMKPg400.3.20,00-B116-MH	5343-47213-xx	20	21.5	3 x 132.6	28.8/29.9	116 x 160	1.6	4
PhMKPg400.3.25,00-B116-MH	5343-47215-xx	25	26.9	3 x 165.8	36.1/37.4	116 x 190	1.9	4
PhMKPg400.3.30,00-B136-MH	5343-47500-xx	30	32.3	3 x 198.9	43.3/44.9	136 x 190	2.0	5

Notes

- Other voltage ratings, outputs, and frequencies upon request. All PhMKP-type capacitors may be also be applied in 60 Hz networks, output and current will, however, be 20 % higher in these cases (i.e. additional thermal load and therefore, a lower class of temperature must be taken into account)

⁽¹⁾ Version no. xx may differ as it respects small changes, e.g. on the label

RATED VOLTAGE 440 V, 50 Hz, DELTA CONNECTION, UL/ULC								
CAN BE USED ALSO FOR 415 V								
TYPE	ARTICLE NO. ⁽¹⁾	OUTPUT kvar 440 V	OUTPUT kvar 415 V	CAP. μF	CURRENT A 440 V/415 V	DIMENSIONS \varnothing x H mm	WEIGHT kg	DRAWING NO.
PhMKPg440.3.02,50-A64-MH	5341-48222-xx	2.5	2.2	3 x 13.7	3.3/3.1	64 x 190	0.6	1
PhMKPg440.3.05,00-A64-MH	5343-48209-xx	5	4.4	3 x 27.4	6.6/6.1	64 x 190	0.6	1
PhMKPg440.3.08,33-A64-MH	5343-48210-xx	8.33	7.4	3 x 45.7	10.9/10.3	64 x 190	0.6	1
PhMKPg440.3.10,00-A64-MH	5343-48211-xx	10	8.9	3 x 54.8	13.1/12.4	64 x 265	0.8	1
PhMKPg440.3.11,20-A64-MH	5343-48212-xx	11.2	10	3 x 61.4	14.7/13.9	64 x 265	0.8	1
PhMKPg440.3.12,50-A64-MH	5343-48213-xx	12.5	11.1	3 x 68.5	16.4/15.4	64 x 265	0.8	1
PhMKPg440.3.14,00-A64-MH	5343-48214-xx	14	12.5	3 x 76.7	18.4/17.4	64 x 265	1.0	1
PhMKPg440.3.12,50-A84-MH	5343-48509-xx	12.5	11.1	3 x 68.5	16.4/15.5	84.4 x 190	1.0	3
PhMKPg440.3.14,10-A84-MH	5343-48510-xx	14.1	12.5	3 x 77.0	18.5/17.5	84.4 x 190	1.1	3
PhMKPg440.3.15,00-A84-MH	5343-48511-xx	15	13.3	3 x 82.2	19.7/18.6	84.4 x 190	1.1	3
PhMKPg440.3.16,90-A84-MH	5343-48512-xx	16.9	15	3 x 92.6	22.2/20.9	84.4 x 190	1.2	3
PhMKPg440.3.18,80-A84-MH	5343-48513-xx	18.8	16.67	3 x 103.0	24.7/23.3	84.4 x 265	1.3	3
PhMKPg440.3.20,00-A84-MH	5343-48514-xx	20	17.8	3 x 109.6	26.2/24.8	84.4 x 265	1.4	3
PhMKPg440.3.22,50-A84-MH	5343-48515-xx	22.5	20	3 x 123.3	29.5/27.8	84.4 x 265	1.4	3
PhMKPg440.3.25,00-A84-MH	5343-48516-xx	25	22.2	3 x 137.0	32.8/30.9	84.4 x 265	1.5	3
PhMKPg440.3.28,10-A84-MH	5343-48517-xx	28.1	25	3 x 154.0	36.9/34.8	84.4 x 265	1.5	3
PhMKPg440.3.30,00-A84-MH	5343-48518-xx	30	26.7	3 x 164.4	39.4/37.1	84.4 x 340	1.8	3
PhMKPg440.3.14,10-B116-MH	5343-47269-xx	14.1	12.5	3 x 77.0	18.5/17.5	116 x 160	1.0	4
PhMKPg440.3.18,80-B116-MH	5343-47217-xx	18.8	16.67	3 x 103.0	24.7/23.3	116 x 160	1.5	4
PhMKPg440.3.20,00-B116-MH	5343-47218-xx	20	17.8	3 x 109.6	26.2/24.8	116 x 160	1.6	4
PhMKPg440.3.22,50-B116-MH	5343-47219-xx	22.5	20	3 x 123.3	29.5/27.8	116 x 160	1.6	4
PhMKPg440.3.25,00-B116-MH	5343-47220-xx	25	22.2	3 x 137.0	32.8/30.9	116 x 190	1.7	4
PhMKPg440.3.28,10-B116-MH	5343-47205-xx	28.1	25	3 x 154.0	36.9/34.8	116 x 190	1.6	4
PhMKPg440.3.30,00-B136-MH	5343-47501-xx	30	26.7	3 x 164.4	39.4/37.1	136 x 190	1.9	5
PhMKPg440.3.33,00-B136-MH	5343-47502-xx	33	29.4	3 x 180.9	43.3/40.9	136 x 190	2.0	5

Notes

- Other voltage ratings, outputs, and frequencies upon request. All PhMKP-type capacitors may be also be applied in 60 Hz networks, output and current will, however, be 20 % higher in these cases (i.e. additional thermal load and therefore, a lower class of temperature must be taken into account)

⁽¹⁾ Version no. xx may differ as it respects small changes, e.g. on the label

RATED VOLTAGE 525 V, 50 Hz, DELTA CONNECTION, UL/ULC								
CAN BE USED ALSO FOR 480 V								
TYPE	ARTICLE NO. ⁽¹⁾	OUTPUT kvar 525 V	OUTPUT kvar 480 V	CAP. μ F	CURRENT A 525 V/480 V	DIMENSIONS \varnothing x H mm	WEIGHT kg	DRAWING NO.
PhMKPg525.3.03,00-A64-MH	5343-48215-xx	3	2.5	3 x 11.5	3.3/3.0	64 x 190	0.6	1
PhMKPg525.3.05,00-A64-MH	5343-48216-xx	5	4.2	3 x 19.2	5.5/5.0	64 x 190	0.6	1
PhMKPg525.3.08,33-A64-MH	5343-48217-xx	8.33	7	3 x 32.1	9.2/8.4	64 x 190	0.6	1
PhMKPg525.3.10,00-A64-MH	5343-48218-xx	10	8.33	3 x 38.5	11.0/10.1	64 x 265	0.7	1
PhMKPg525.3.10,00-A84-MH	5343-48519-xx	10	8.33	3 x 38.5	11.0/10.1	84.4 x 190	0.8	3
PhMKPg525.3.12,50-A84-MH	5343-48520-xx	12.5	10.4	3 x 48.1	13.7/12.6	84.4 x 190	1.0	3
PhMKPg525.3.13,80-A84-MH	5343-48521-xx	13.8	11.5	3 x 53.1	15.2/13.8	84.4 x 190	1.0	3
PhMKPg525.3.15,00-A84-MH	5343-48522-xx	15	12.5	3 x 57.7	16.5/15.0	84.4 x 190	1.2	3
PhMKPg525.3.20,00-A84-MH	5343-48523-xx	20	16.7	3 x 77.0	22.0/20.1	84.4 x 265	1.3	3
PhMKPg525.3.25,00-A84-MH	5343-48524-xx	25	20.9	3 x 96.2	27.5/24.6	84.4 x 265	1.5	3
PhMKPg525.3.20,00-B116-MH	5343-47266-xx	20	16.7	3 x 77.0	22.0/20.1	116 x 160	1.4	4
PhMKPg525.3.25,00-B116-MH	5343-47227-xx	25	20.9	3 x 96.2	27.5/25.1	116 x 190	1.5	4
PhMKPg525.3.30,00-B116-MH	5343-47267-xx	30	25.1	3 x 115.4	33.0/30.2	116 x 230	2.0	4
PhMKPg525.3.30,00-B136-MH	5343-47503-xx	30	25.1	3 x 115.4	33.0/30.2	136 x 190	1.8	5
PhMKPg525.3.35,90-B116-MH	5343-47271-xx	35.9	30	3 x 138.2	39.5/36.1	116 x 265	2.1	4
PhMKPg525.3.35,90-B136-MH	5343-47504-xx	35.9	30	3 x 138.2	39.5/36.1	136 x 230	2.1	5
PhMKPg525.3.37,10-B116-MH	5343-47272-xx	37.1	31	3 x 142.8	40.8/37.3	116 x 265	2.2	4
PhMKPg525.3.37,10-B136-MH	5343-47505-xx	37.1	31	3 x 142.8	40.8/37.3	136 x 230	2.2	5

Notes

- Other voltage ratings, outputs, and frequencies upon request. All PhMKP-type capacitors may be also be applied in 60 Hz networks, output and current will, however, be 20 % higher in these cases (i.e. additional thermal load and therefore, a lower class of temperature must be taken into account)
- (1) Version no. xx may differ as it respects small changes, e.g. on the label

RATED VOLTAGE 660 V, 50 Hz, 64/84: DELTA CONNECTION, 116/136: STAR CONNECTION, UL/ULC UP TO 660 V

CAN BE USED ALSO FOR 690 V, FULL OVER VOLTAGE RANGE

TYPE	ARTICLE NO. ⁽¹⁾	OUTPUT kvar 660 V	OUTPUT kvar 690 V	CAP. μ F	CURRENT A 660 V/690 V	DIMENSIONS \varnothing x H mm	WEIGHT kg	DRAWING NO.
PhMKPg660.3.05,00-A64-MH	5343-48219-xx	5	5.5	3 x 12.2	4.4/4.6	64 x 190	0.6	1
PhMKPg660.3.08,33-A64-MH	5343-48220-xx	8.33	9.1	3 x 20.3	7.3/7.6	64 x 265	0.8	1
PhMKPg660.3.08,33-A84-MH	5343-48525-xx	8.33	9.1	3 x 20.3	7.3/7.6	84.4 x 190	0.9	3
PhMKPg660.3.10,00-A84-MH	5343-48526-xx	10	10.9	3 x 24.4	8.7/9.1	84.4 x 190	1.1	3
PhMKPg660.3.12,50-A84-MH	5343-48527-xx	12.5	13.7	3 x 30.4	10.9/11.4	84.4 x 265	1.2	3
PhMKPg660.3.15,00-A84-MH	5343-48528-xx	15	16.4	3 x 36.5	13.1/13.7	84.4 x 265	1.4	3
PhMKPg660.3.16,70-A84-MH	5343-48529-xx	16.7	18.3	3 x 40.7	14.6/15.3	84.4 x 265	1.5	3
PhMKPg660.3.20,00-A84-MH	5343-48530-xx	20	21.9	3 x 48.7	17.5/18.3	84.4 x 340	1.7	3
PhMKPg660.3.22,90-A84-MH	5343-48531-xx	22.9	25	3 x 55.8	20/20.9	84.4 x 340	1.9	3
PhMKPg660.2.12,50-B116-MH	5343-47255-xx	12.5	13.7	3 x 91.4	10.9/11.4	116 x 160	1.6	4
PhMKPg660.2.15,00-B116-MH	5343-47256-xx	15	16.4	3 x 109.6	13.1/13.7	116 x 160	1.6	4
PhMKPg660.2.16,70-B116-MH	5343-47257-xx	16.7	18.3	3 x 122.1	14.6/15.3	116 x 160	1.7	4
PhMKPg660.2.20,00-B116-MH	5343-47259-xx	20	21.9	3 x 146.2	17.5/18.3	116 x 190	1.8	4
PhMKPg660.2.22,90-B116-MH	5343-47273-xx	22.9	25	3 x 167.3	20/20.9	116 x 190	1.7	4
PhMKPg660.2.25,00-B136-MH	5343-47506-xx	25	27.3	3 x 182.6	21.9/22.9	136 x 190	1.6	5
PhMKPg660.2.30,00-B136-MH	5343-47507-xx	30	32.8	3 x 219.3	26.2/27.4	136 x 230	2.2	5

RATED VOLTAGE 690 V, 50 Hz, 64/84: DELTA CONNECTION, 116/136: STAR CONNECTION

CAN BE USED ALSO FOR 660 V

TYPE	ARTICLE NO. ⁽¹⁾	OUTPUT kvar 690 V	OUTPUT kvar 660 V	CAP. μ F	CURRENT A 690 V/660 V	DIMENSIONS \varnothing x H mm	WEIGHT kg	DRAWING NO.
PhMKPg690.3.10,00-A64-MH	5343-48221-xx	10	9.1	3 x 22.3	8.4/8.0	64 x 265	0.9	1
PhMKPg690.3.12,50-A84-MH	5343-48532-xx	12.5	11.4	3 x 27.9	10.5/10.0	84.4 x 265	1.1	3
PhMKPg690.3.15,00-A84-MH	5343-48533-xx	15	13.7	3 x 33.4	12.5/12.0	84.4 x 265	1.3	3
PhMKPg690.3.20,00-A84-MH	5343-48534-xx	20	18.3	3 x 44.6	16.7/16.0	84.4 x 340	1.6	3
PhMKPg690.3.25,00-A84-MH	5343-48535-xx	25	22.9	3 x 55.7	20.9/20.0	84.4 x 340	1.9	3
PhMKPg690.2.12,50-B116-MH	5343-47274-xx	12.5	11.4	3 x 83.6	10.5/10.0	116 x 160	1.2	4
PhMKPg690.2.15,00-B116-MH	5343-47275-xx	15	13.7	3 x 100.3	12.5/12.0	116 x 160	1.3	4
PhMKPg690.2.20,00-B116-MH	5343-47276-xx	20	18.3	3 x 133.7	16.7/16.0	116 x 190	1.5	4
PhMKPg690.2.25,00-B116-MH	5343-47277-xx	25	22.9	3 x 167.3	20.9/20.0	116 x 190	1.6	4

Notes

- Other voltage ratings, outputs, and frequencies upon request. All PhMKPg-type capacitors may be also be applied in 60 Hz networks, output and current will, however, be 20 % higher in these cases (i.e. additional thermal load and therefore, a lower class of temperature must be taken into account)

⁽¹⁾ Version no. xx may differ as it respects small changes, e.g. on the label

RATED VOLTAGE 230 V, 50 Hz, UL/ULC								
TYPE	ARTICLE NO. (1)	OUTPUT kvar	CAP. μ F	CURRENT A	DIMENSIONS \varnothing x H (mm)	WEIGHT kg	DRAWING NO.	PROTECTIVE CLASS
IP20								
PhMKP230.1.02,50-A64-MH	5341-48322-xx	2.5	150.0	10.9	64 x 140	0.6	1	IP20
PhMKP230.1.03,33-A64-MH	5341-48323-xx	3.33	200.4	14.5	64 x 190	0.7	1	IP20
PhMKP230.1.04,17-A64-MH	5341-48324-xx	4.17	251.0	18.1	64 x 190	0.8	1	IP20
PhMKP230.1.05,00-A84-MH	5341-48636-xx	5	300.0	21.7	84.4 x 140	0.9	3	IP20
IP00								
PhMKP230.1.05,00-84-MH	5341-44436-xx	5	300.0	21.7	84.4 x 140	0.9	2	IP00

RATED VOLTAGE 400 V, 50 Hz, UL/ULC									
CAN BE USED ALSO FOR 415 V, FULL OVER VOLTAGE RANGE									
TYPE	ARTICLE NO. (1)	OUTPUT kvar 400 V	OUTPUT kvar 415 V	CAP. μ F	CURRENT A 400 V/415 V	DIMENSIONS \varnothing x H mm	WEIGHT kg	DRAWING NO.	PROTECTIVE CLASS
IP20									
PhMKP400.1.02,50-A64-MH	5341-48325-xx	2.5	2.7	49.7	6.3/6.5	64 x 82	0.3	1	IP20
PhMKP400.1.03,33-A64-MH	5341-48326-xx	3.33	3.6	66.2	8.3/8.6	64 x 109	0.4	1	IP20
PhMKP400.1.05,00-A64-MH	5341-48327-xx	5	5.4	99.5	12.5/13.0	64 x 140	0.5	1	IP20
PhMKP400.1.06,67-A64-MH	5341-48328-xx	6.67	7.2	132.7	16.7/17.3	64 x 190	0.7	1	IP20
PhMKP400.1.08,33-A64-MH	5341-48329-xx	8.33	9	165.7	20.8/21.6	64 x 190	0.8	1	IP20
PhMKP400.1.10,00-A64-MH	5341-48330-xx	10	10.8	198.9	25.0/25.9	64 x 240	0.9	1	IP20
PhMKP400.1.08,33-A84-MH	5341-48637-xx	8.33	9	165.7	20.8/21.6	84.4 x 140	0.9	3	IP20
PhMKP400.1.10,00-A84-MH	5341-48638-xx	10	10.8	198.9	25.0/25.9	84.4 x 140	1.0	3	IP20
PhMKP400.1.16,70-A84-MH	5341-48639-xx	16.7	18	332.2	41.7/43.3	84.4 x 240	1.3	3	IP20
IP00									
PhMKP400.1.08,33-84-MH	5341-44437-xx	8.33	9	165.7	20.8/21.6	84.4 x 140	0.9	2	IP00
PhMKP400.1.10,00-84-MH	5341-44438-xx	10	10.8	198.9	25.0/25.9	84.4 x 140	1.0	2	IP00
PhMKP400.1.16,70-84-MH	5341-44439-xx	16.7	18	332.2	41.7/43.3	84.4 x 240	1.3	2	IP00

RATED VOLTAGE 525 V, 50 Hz, UL/ULC									
CAN BE USED ALSO FOR 480 V									
TYPE	ARTICLE NO. (1)	OUTPUT kvar 525 V	OUTPUT kvar 480 V	CAP. μ F	CURRENT A 525 V/480 V	DIMENSIONS \varnothing x H mm	WEIGHT kg	DRAWING NO.	PROTECTIVE CLASS
IP20									
PhMKP525.1.05,00-A64-MH	5341-48331-xx	5	4.2	57.7	9.5/8.8	64 x 140	0.5	1	IP20
PhMKP525.1.08,33-A64-MH	5341-48332-xx	8.33	7.0	96.2	15.9/14.6	64 x 190	0.7	1	IP20
PhMKP525.1.10,00-A64-MH	5341-48333-xx	10	8.4	115.5	19.0/17.5	64 x 240	0.9	1	IP20
PhMKP525.1.16,70-A84-MH	5341-48640-xx	16.7	14.0	192.9	31.6/29.2	84.4 x 240	1.3	3	IP20
PhMKP525.1.20,00-A84-MH	5341-48641-xx	20	16.7	231.0	38.0/34.8	84.4 x 240	1.3	3	IP20
IP00									
PhMKP525.1.16,70-84-MH	5341-44440-xx	16.7	14.0	192.9	31.6/29.2	84.4 x 240	1.3	2	IP00
PhMKP525.1.20,00-84-MH	5341-44441-xx	20	16.7	231.0	38.0/34.8	84.4 x 240	1.3	2	IP00

Notes

- Other voltage ratings, outputs, and frequencies upon request. All PhMKP-type capacitors may be also be applied in 60 Hz networks, output and current will, however, be 20 % higher in these cases (i.e. additional thermal load and therefore, a lower class of temperature must be taken into account)

(1) Version no. xx may differ as it respects small changes, e.g. on the label

DIMENSIONS

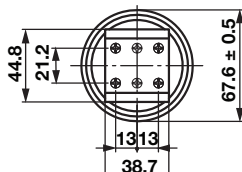
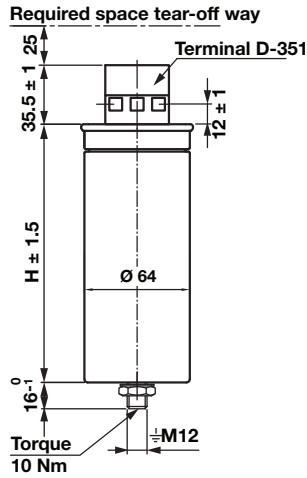

Drawing 1

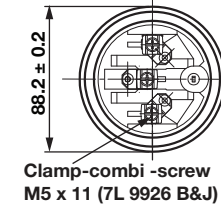
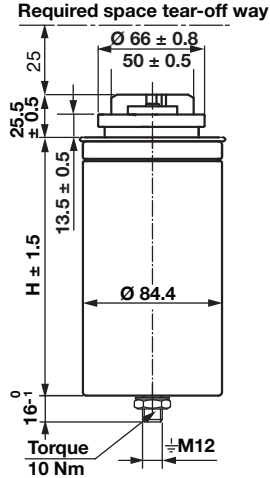

Drawing 2

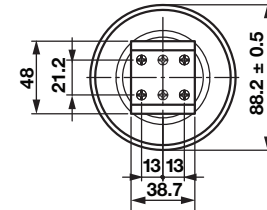
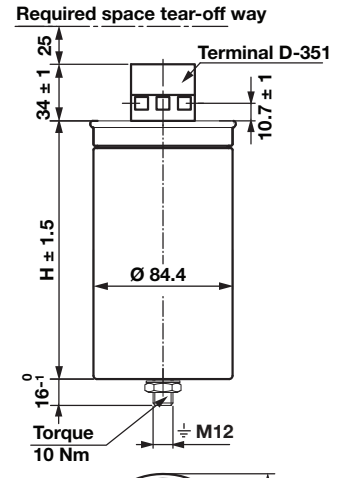

Drawing 3

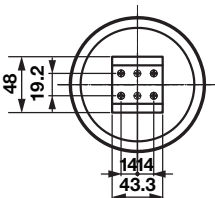
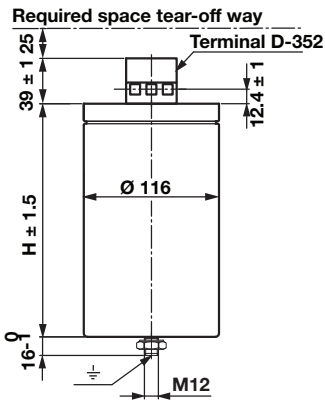

Drawing 4

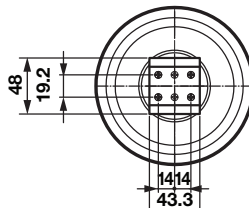
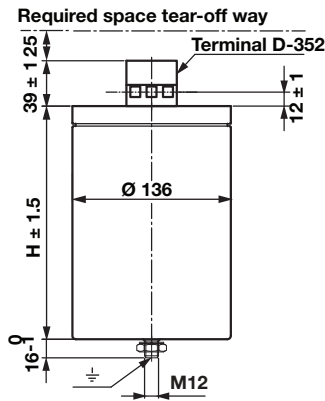

Drawing 5

ORDERING INFORMATION

TECHNICAL UNITS

Full cardboard boxes:	$\text{Ø } 64$ mm - 9 pcs per carton
	$\text{Ø } 84.4$ mm - 4 pcs per carton
	$\text{Ø } 116$ mm - 4 pcs per carton
	$\text{Ø } 136$ mm - 2 pcs per carton

ESTAdry D-Type, LVAC Power Capacitors



FEATURES

- Self-healing technology
- Over pressure tear-off fuse
- Smallest available height for 50 kvar units: 210 mm (+ 68 mm for terminals)
- Excellent heat dissipation
- Screw-on terminal with M10 bolts
- Resin filling provides thermal conductivity similar to that of oil-filled capacitors
- Aluminum case is welded and hermetically sealed
- No paint required for OUTDOOR application
- UL and cUL approved

APPLICATIONS

- Areas with dust and moisture, which require a high degree of protection and high creepage distances. Also for OUTDOOR
- Free standing, fixed individual-PFC (e.g. motors, lighting, transformers)
- Automatic central-PFC (e.g. group of loads)
- Harmonic trap (e.g. UPS, frequency drives, converter)
- Pole mounted PFC

QUICK REFERENCE DATA		
Series	PhMKDg..., triangular	PhMKDgF..., triangular
Description	ESTAdry D-type, LVAC power capacitors - dry - INDOOR , IP00	ESTAdry D-type, LVAC power capacitors - dry - OUTDOOR , IP00
Type	Capacitors, fixed, low voltage	Capacitors, fixed, low voltage
Technology	MKP, metallized polypropylene film	MKP, metallized polypropylene film
Voltage max. (V)	1000	1000
Capacitance min. (µF)	3-phase D: 3 x 115.5, 3-phase Y: 3 x 140.1	3-phase D: 3 x 115.5, 3-phase Y: 3 x 140.1
Capacitance max. (µF)	3-phase D: 3 x 331.6, 3-phase Y: 3 x 334.3	3-phase D: 3 x 331.6, 3-phase Y: 3 x 334.3
Output min. (kvar)	30	30
Output max. (kvar)	56.2	56.2

CAPACITORS IN TRIANGULAR CASING

DESCRIPTION

The PhMKDg series capacitor in a triangular aluminum case with a standard rating of 50 kvar, augments Vishay ESTA broad line of reliable three-phase power capacitors. The PhMKDg series is preceded by our PhMKP and the ESTAdry PhMKPg series in aluminum tubular casings, with outputs up to 37 kvar, depending on their rated voltage.

The standard PhMKDg series capacitor is designed for indoor application, with externally arranged discharge resistors ($U \leq 50 \text{ V}/60 \text{ s}$). For outdoor application, the discharge resistors can be incorporated internally ($U \leq 75 \text{ V}/180 \text{ s}$). Also, the pure aluminum welded cases render these capacitors perfectly suitable for outdoor use.

The PhMKDg capacitor can be used for both controlled equipment and for stationary or mobile fixed compensation, e.g. for induction-motor-operated conveyer belts in the mining industry.

The indoor capacitor can be supplied with the option of a small protective cover for each individual connection or with an IP53-type overall protective cover.

The triangular case and corresponding triangular arrangement of the winding elements allows for simple connection in parallel of several units (IN-LINE). The joint insulation created by means of a solid ceramic terminal base with high surface-creepage resistance and very long tracking paths establishes an additionally superior mechanical stability for the three solid connector bolts.

With a resin filled pure aluminum case offering superior mechanical stability, low profile design, excellent thermal conductance, easy paralleling and a complete three-phase tear-off fuse system incorporated into the PhMKDg design, this series is the ideal first choice for new designs and applicable retrofit requirements.

3-PHASE CAPACITOR, INDOOR



Single bolt protection



IP53

3-PHASE CAPACITOR, OUTDOOR



ESTAdry D-TYPE PhMKDg, INDOOR

TECHNICAL DATA	
STANDARDS	IEC 60831-1 + 2, EN 60831-1 + 2, UL810 LATEST EDITION UL/ULC FILE # E97723
Overvoltages (in accordance with the above standards)	U _{cn} + 10 % (up to 8 h daily) U _{cn} + 15 % (up to 30 min daily) U _{cn} + 20 % (up to 5 min, only 200 times in the life of the capacitor) U _{cn} + 30 % (up to 1 min, only 200 times in the life of the capacitor) Please also refer to "Terms and Definitions".
Overcurrent (in accordance with the above standards)	1.3 x I _n , 1.5 x I _n with 10 % overvoltages, 15 % over capacitance and harmonics included, continuous operation Please also refer to "Terms and Definitions".
Tolerance on capacitance	- 5/+ 10 % in accordance with the standards ± 5 % as Vishay ESTA standard
Test voltage, terminal/terminal	2.15 x U _{cn} , VAC, 2 s (routine test)
Test voltage, terminal/casing	6000 VAC, 2 s (routine test)
Inrush current	300 times rated current I _n
Losses	≤ 0.4 W/kvar to 0.5 W/kvar (without discharge resistors)
Statistical life expectancy	> 130 000 operating h (ESTAdry)
Degree of protection	IP00 (terminal cover for higher protection class upon request), indoor
Ambient temperature category	- 25/D (max. 55 °C), (- 40/D on request)
Permitted casing temperature	Max. 65 °C (measured on top of the can)
Cooling	Naturally air-cooled
Permissible relative humidity	Maximum 95 %
Maximum allowed altitude	2000 m above sea level
Mounting position	Vertical and horizontal
Mounting and grounding	Threaded M12 stud at the bottom of the container
Safety features	All-phase overpressure tear-off fuse, self-healing
Casing	Aluminum can, welded top
Dielectric	Polypropylene film, self-healing
Filling agent	Resin-filled (ESTAdry), non-PCB, non-toxic
Terminals	Threaded studs M10

3-PHASE CAPACITORS IN TRIANGULAR CASING, INDOOR

TYPE	ARTICLE NO. (1)	RATED VOLTAGE V	RATED OUTPUT kvar	CAPACITANCE μF	CURRENT A (50 Hz)	WEIGHT kg	HEIGHT H mm
PhMKDg400.3.50-MH	5345-44814-xx	400	50	3 x 331.6 Δ	72.2	4.0	210
PhMKDg440.3.50-MH	5345-44804-xx	440	50	3 x 274.0 Δ	65.6	4.0	210
PhMKDg440.3.56, 2-MH	5345-44805-xx	440/415	56.2/50	3 x 308.0 Δ	73.7/69.6	4.0	210
PhMKDg460.3.50-MH	5345-44803-xx	460	50	3 x 250.7 Δ	62.8	4.0	210
PhMKDg525.3.50-MH	5345-44806-xx	525	50	3 x 192.5 Δ	55.0	4.0	210
PhMKDg690.2.50-MH	5345-44807-xx	690	50	3 x 334.3 Y	41.8	4.0	210
PhMKDg760.2.50-MH	5345-44808-xx	760	50	3 x 275.5 Y	38.0	4.0	210

ORDERING INFORMATION

Packing units	1 piece per carton
---------------	--------------------

Notes

- Other voltage ratings, outputs, and frequencies on request.
- (1) Version no. xx may differ as it respects small changes, e.g. on the label

DIMENSIONS, INDOOR

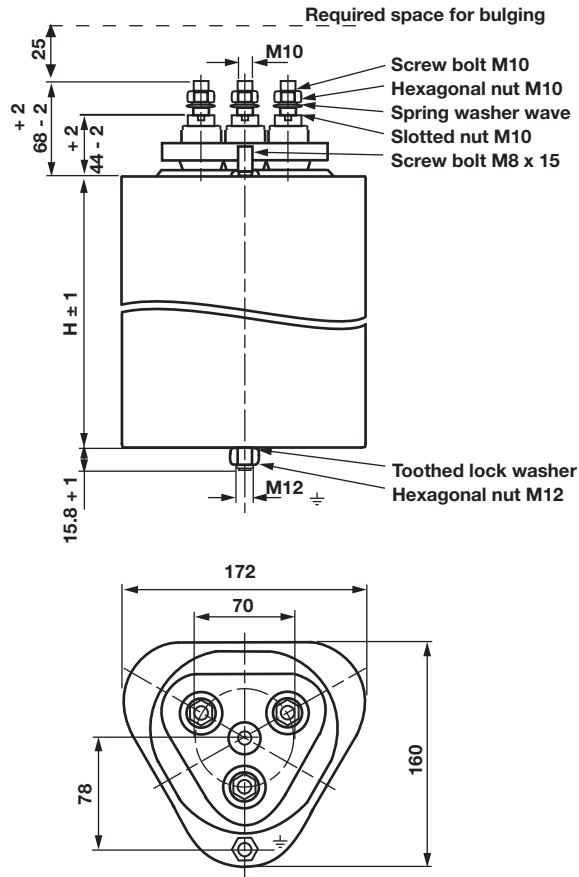

Drawing 6

DISCHARGE RESISTORS

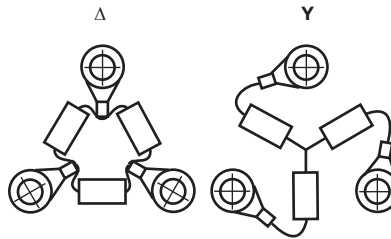

RECOMMENDED TORQUES	
STYLE	RECOMMENDED TORQUE
Terminals M8	6 Nm
Terminals M10	10 Nm
M12 mounting stud	10 Nm

ESTAdry D-TYPE PhMKDgF, LVAC POWER CAPACITORS, OUTDOOR

TECHNICAL DATA	
STANDARDS	IEC 60831-1 + 2, EN 60831-1 + 2, LATEST EDITION
Overvoltages (in accordance with the above standards)	$U_{cn} + 10\%$ (up to 8 h daily) $U_{cn} + 15\%$ (up to 30 min daily) $U_{cn} + 20\%$ (up to 5 min, only 200 times in the life of the capacitor) $U_{cn} + 30\%$ (up to 1 min, only 200 times in the life of the capacitor) Please also refer to "Terms and Definitions".
Overcurrent (in accordance with the above standards)	$1.3 \times I_n$, $1.5 \times I_n$ with 10 % overvoltages, 15 % over capacitance and harmonics included, continuous operation "Please also refer to Terms and Definitions".
Tolerance on capacitance	- 5/+ 10 % in accordance with the standards ± 5 % as Vishay ESTA standard
Test voltage, terminal/terminal	$2.15 \times U_{cn}$, VAC, 2 s (routine test)
Test voltage, terminal/casing	6000 VAC, 2 s (routine test)
Inrush current	300 times rated current I_n
Losses	≤ 0.4 W/kvar to 0.5 W/kvar (without discharge resistors)
Statistical life expectancy	> 130 000 operating h (ESTAdry)
Degree of protection	IP00 outdoor
Ambient temperature category	- 25/D (max. 55 °C), (- 40/D on request)
Permitted casing temperature	Max. 65 °C (measured on top of the can)
Cooling	Naturally air-cooled
Permissible relative humidity	Maximum 95 %
Maximum allowed altitude	2000 m above sea level
Mounting position	Vertical and horizontal
Mounting and grounding	Threaded M12 stud at the bottom of the container
Safety features	All-phase overpressure tear-off fuse, self-healing
Casing	Aluminum can, welded top
Dielectric	Polypropylene film, self-healing
Filling agent	Resin-filled (ESTAdry), non-PCB, non-toxic
Terminals	Threaded studs M10

Available types same as for indoor use, different type designation "F".
For example:

TYPE	RATED VOLTAGE V	RATED OUTPUT kvar	CAPACITANCE μF	CURRENT A (50 Hz)	WEIGHT kg	HEIGHT H mm
PhMKDgF460.3.50-MH	460	50	3 x 250.7 Δ	62.8	4.0	210

ORDERING INFORMATION

Packing units	1 piece per carton
---------------	--------------------

RECOMMENDED TORQUES

STYLE	RECOMMENDED TORQUE
Terminals M8	6 Nm
Terminals M10	10 Nm
M12 mounting stud	10 Nm

Note

- Other voltage ratings, output, and frequencies upon request

DIMENSIONS, OUTDOOR

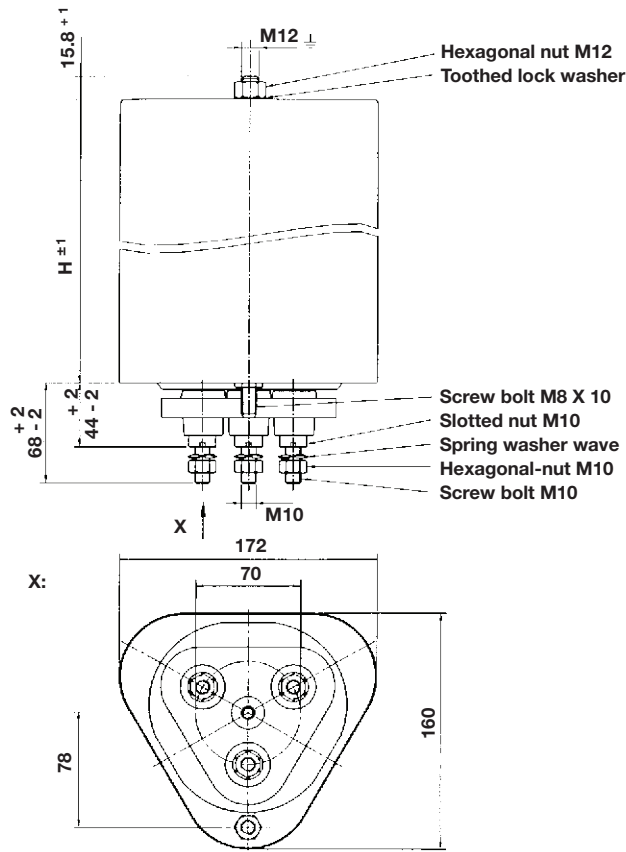

Drawing 7

ACCESSORIES: SUPPORT FOR POLE AND WALL MOUNTING

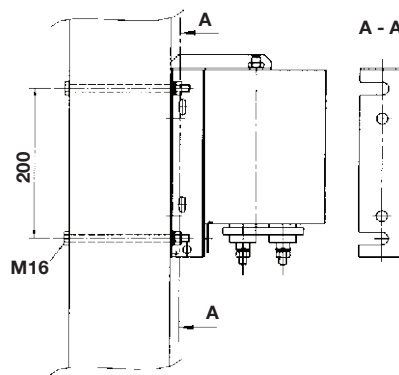

LVAC Power Capacitors



FEATURES

- Self-healing technology
- Over pressure tear-off fuse
- Robust steel container
- Massive connection studs

APPLICATIONS

- Areas with dust and moisture, which require a high degree of protection and high creepage distances
- Free standing, fixed individual-PFC (e.g. motors, lighting, transformers)
- Automatic central-PFC (e.g. group of loads)
- Harmonic trap (e.g. UPS, frequency drives, converter)

QUICK REFERENCE DATA	
Series	PhMKP..., rectangular
Description	LVAC power capacitors - oil/dry - INDOOR , IP00 - IP43
Type	Capacitors, fixed, low voltage
Technology	MKP, metallized polypropylene film
Voltage max. (V)	690
Capacitance min. (μ F)	3-phase D: 3 x 22.3
Capacitance max. (μ F)	3-phase D: 3 x 663
Output min. (kvar)	10
Output max. (kvar)	100

**CAPACITORS IN RECTANGULAR CASING
DESCRIPTION**

ESTAprop PhMKP-type capacitors in rectangular steel casing have been designed for power factor correction in low voltage plants. Loads as motors and transformers consume real power as well as reactive power. Generators, supply cables, and other electrical distribution equipment should be relieved from reactive power.

DESIGN

The ESTAprop MKP capacitor in steel casing consists of a number of three-phase tubular can type capacitors (see PhMKP... Cylindrical Aluminum). The individual aluminum cans are wired together and mounted onto a steel frame. The steel frame together with the cans is housed in a common sheet steel casing. The supply cable may be connected at three threaded studs, on top of the capacitor. A threaded stud M10 for grounding is available. Easy mounting will be ensured by 4 drillings, at the bottom of the container.

This design ensures highest safety by:

- self-healing technology
- over pressure tear-off fuse
- robust steel container
- massive connection studs

**RECTANGULAR CAPACITOR,
IP43****RECTANGULAR CAPACITOR, BE-TYPE,
IP00**

TECHNICAL DATA	
STANDARDS	IEC 60831-1 + 2, EN 60831-1 + 2, LATEST EDITIONS
Overvoltages (in accordance with the above standards)	$U_{cn} + 10\%$ (up to 8 h daily) $U_{cn} + 15\%$ (up to 30 min daily) $U_{cn} + 20\%$ (up to 5 min, only 200 times in the life of the capacitor) $U_{cn} + 30\%$ (up to 1 min, only 200 times in the life of the capacitor) Please also refer to "Terms and Definitions".
Overcurrent (in accordance with the above standards)	$1.3 \times I_n$, $1.5 \times I_n$ with 10 % overvoltages, 15 % overcapacitance and harmonics included, continuous operation Please also refer to "Terms and Definitions".
Tolerance on capacitance	- 5 %/+ 10 % in accordance with the standards ± 5 % as Vishay ESTA standard
Test voltage, terminal/terminal	$2.15 \times U_{cn}$, VAC, 2 s (routine test)
Test voltage, terminal/casing	4800 VAC, 2 s (routine test)
Inrush current	300 times rated current in
Losses	< 0.50 W/kvar
Statistical life expectancy	> 100 000 operating hours
Degree of protection	IP00, IP43, indoor mounting
Permitted ambient temperature	- 25 °C/up to 55 °C (depending on output)
Permitted casing temperature	Max. 60 °C (measured on top of the capacitor)
Cooling	Naturally air-cooled
Permissible relative humidity	Maximum 95 %
Maximum allowed altitude	2000 m above sea level
Mounting position	Vertical and horizontal
Mounting	4 drillings, Ø 9 mm, at the bottom of the container
Safety features	All-phase over pressure tear-off fuse, self-healing
Casing	Sheet steel casing, color RAL 7033
Dielectric	Polypropylene film, self-healing
Filling agent (of the tubular capacitors inside)	Natural oil, non-PCB, biodegradable (ESTAprop) or dry/gas - filled (ESTAdry)
Terminals	Threaded studs, M12

CAPACITORS IN RECTANGULAR STEEL CASING, IP43

RATED VOLTAGE 400 V ⁽¹⁾, 50 Hz, 3-PHASE, DELTA CONNECTION									
TYPE	ARTICLE NO. ⁽²⁾	OUTPUT kvar	CAPACITANCE μ F	CURRENT A (50 Hz)	DIMENSIONS L x W x H mm	PREVIOUS CABLE ENTRY	NEW CABLE ENTRY	WEIGHT kg	DRAWING NO.
PhMKP400/10-MH	5342-42001-xx	10	3 x 66.3	14.4	260 x 135 x 525	LT21	M32	5	8
PhMKP400/12,5-MH	5342-42002-xx	12.5	3 x 82.9	18	260 x 135 x 525	LT21	M32	5	8
PhMKP400/15-MH	5342-42003-xx	15	3 x 99.5	21.6	260 x 135 x 525	LT21	M32	6	8
PhMKP400/16,7-MH	5342-42004-xx	16.7	3 x 110.7	24.1	260 x 135 x 525	LT21	M32	6	8
PhMKP400/20-MH	5342-42005-xx	20	3 x 133	28.9	260 x 135 x 525	LT21	M32	6.5	8
PhMKP400/25-MH	5342-42006-xx	25	3 x 166	36	260 x 135 x 525	LT21	M32	6.5	8
PhMKP400/30-MH	5342-42007-xx	30	3 x 199	43.3	260 x 135 x 525	LT29	M40	8	8
PhMKP400/33,3-MH	5342-42008-xx	33.3	3 x 221	48	260 x 135 x 525	LT29	M40	8	8
PhMKP400/40-MH	5342-42009-xx	40	3 x 265	57.7	260 x 135 x 525	LT29	M40	9	8
PhMKP400/50-MH	5342-42010-xx	50	3 x 332	72.2	260 x 135 x 525	LT29	M40	10	8
PhMKP400/60-MH	5342-42011-xx	60	3 x 398	86.6	260 x 135 x 525	LT36	M50	11	8
PhMKP400/66,7-MH	5342-42012-xx	66.7	3 x 442	96.3	260 x 135 x 525	LT36	M50	12.5	8
PhMKP400/70-MH	5342-42013-xx	70	3 x 464	101	395 x 135 x 525	LT36	M50	13	8
PhMKP400/75-MH	5342-42014-xx	75	3 x 497	108	395 x 135 x 525	LT36	M50	14	8
PhMKP400/83,3-MH	5342-42015-xx	83.3	3 x 552	120	395 x 135 x 525	LT36	M50	15	8
PhMKP400/100-MH	5342-42016-xx	100	3 x 663	144	395 x 135 x 525	LT42	M63	17	8

CAPACITORS IN RECTANGULAR STEEL CASING, IP00

RATED VOLTAGE 400 V ⁽¹⁾, 50 Hz, 3-PHASE, DELTA CONNECTION							
TYPE	ARTICLE NO. ⁽²⁾	OUTPUT kvar	CAPACITANCE μ F	CURRENT A (50 Hz)	DIMENSIONS L x W x H mm	WEIGHT kg	DRAWING NO.
PhMKP400/10BE-MH	5342-42121-xx	10	3 x 66.3	14.4	260 x 135 x 418	5	9
PhMKP400/12,5BE-MH	5342-42122-xx	12.5	3 x 82.9	18	260 x 135 x 418	5	9
PhMKP400/15BE-MH	5342-42123-xx	15	3 x 99.5	21.6	260 x 135 x 418	6	9
PhMKP400/16,7BE-MH	5342-42124-xx	16.7	3 x 110.7	24.1	260 x 135 x 418	6	9
PhMKP400/20BE-MH	5342-42125-xx	20	3 x 133	28.9	260 x 135 x 418	6.5	9
PhMKP400/25BE-MH	5342-42126-xx	25	3 x 166	36	260 x 135 x 418	6.5	9
PhMKP400/30BE-MH	5342-42127-xx	30	3 x 199	43.3	260 x 135 x 418	8	9
PhMKP400/33,3BE-MH	5342-42128-xx	33.3	3 x 221	48	260 x 135 x 418	8	9
PhMKP400/40BE-MH	5342-42129-xx	40	3 x 265	57.7	260 x 135 x 418	9	9
PhMKP400/50BE-MH	5342-42130-xx	50	3 x 332	72.2	260 x 135 x 418	10	9
PhMKP400/60BE-MH	5342-42131-xx	60	3 x 398	86.6	260 x 135 x 418	11	9
PhMKP400/66,7BE-MH	5342-42132-xx	66.7	3 x 442	96.3	260 x 135 x 418	12.5	9
PhMKP400/70BE-MH	5342-42133-xx	70	3 x 464	101	395 x 135 x 418	13	9
PhMKP400/75BE-MH	5342-42134-xx	75	3 x 497	108	395 x 135 x 418	14	9
PhMKP400/83,3BE-MH	5342-42135-xx	83.3	3 x 552	120	395 x 135 x 418	15	9
PhMKP400/100BE-MH	5342-42136-xx	100	3 x 663	144	395 x 135 x 418	17	9

Notes

- Other voltage ratings, outputs, and frequencies upon request.
All PhMKP-type capacitors may be used for 60 Hz, the output will be 1.2 times higher.
- All oil-impregnated part types can also be produced in a PhMKPg dry version. Dimensions and ratings are unchanged.
Dry types are not standard stock items, with production upon request.

⁽¹⁾ Can be used also for 415 V, with full overvoltage range.

⁽²⁾ Version no. xx may differ as it respects small changes, e.g. on the label.

DIMENSIONS

Drawing 8

Rectangular-type capacitor,
three phase, IP43

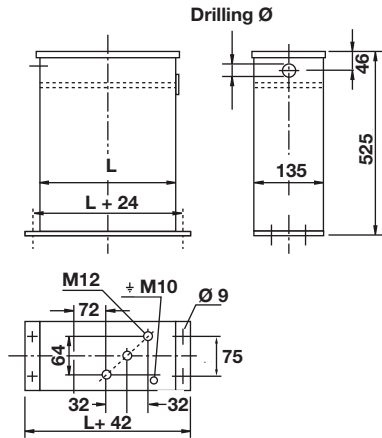

Drawing 9

Rectangular-type, BE-capacitor,
three phase, IP00 418 mm high

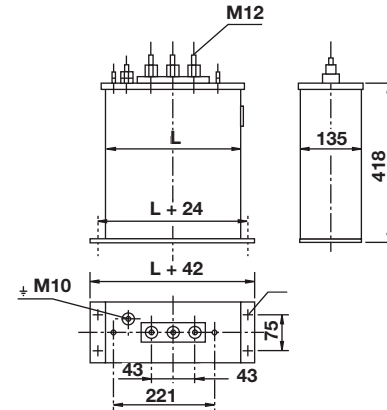

RECOMMENDED TORQUES	
TERMINAL STYLE	RECOMMENDED TORQUE
Terminals M6	3 Nm
Terminals M8	6 Nm
Terminals M10	10 Nm
Terminals M12	15.5 Nm

CABLE GLANDS AND GASKETS				
OUTPUT IN kvar/400 V, 50 Hz	PG	DRILLING Ø IN mm (PG)	M	DRILLING Ø IN mm (M)
10 to 25	21	28.5	32	34
30 to 50	29	38	40	42
60 to 83.3	36	48	50	50.5
100	42	55	63	63.5

ORDERING INFORMATION	
MINIMUM ORDER QUANTITY PER TYPE AND ORDER	DELIVERY TIME
1 unit	Delivery time is approximately 4 weeks

LVAC DW-Type Filter Capacitors



FEATURES

- High output and high over-current design
- Welded rectangular capacitors with 3 or 6 terminals
- Overpressure monitoring device

APPLICATIONS

- Automatic and individual fixed Power Factor Correction in LVAC applications
- Detuned and tuned filter applications to reduce harmonics in LVAC networks

QUICK REFERENCE DATA	
Series	PhMKP.../-DW
Description	DW-Type High Current Filter Capacitors - Oil/DRY - INDOOR , IP00, 3-phase/1-phase
Type	Capacitors, fixed, low voltage
Technology	MKP, metallized polypropylene film
Voltage max. (V)	1000
Capacitance min. (μF)	1-phase: 200 μF , 3-phase D: 3 x 70 μF , 3-phase Y: 3 x 219 μF
Capacitance max. (μF)	1-phase: 3600 μF , 3-phase D: 3 x 780 μF , 3-phase Y: 3 x 1700 μF
Output min. (kvar)	30
Output max. (kvar)	450

DW-FILTER TYPE CAPACITORS**APPLICATION**

ESTAprop and ESTAdry DW-type capacitors in rectangular steel or Aluminum casing have been designed for high current filter circuit applications in low voltage plants. Loads such as frequency drives, converters, and other non-linear loads create harmonics. The purpose of tuned and detuned filters is the protection of electrical equipment and reduction of harmonics. DW-type capacitors have an excellent current-carrying capability and may be built for high voltages as well as high loads within one casing.

DW-type capacitors may be used for:

- fixed detuned power factor correction equipment
- automatic detuned power factor correction equipment
- tuned filter circuits

DESIGN

The DW-type capacitor is based on MKP-technology. The active element consists of metallized polypropylene film with self-healing properties. The current-carrying metal layer is vaporised onto one side of the polypropylene film. The front surface of tubular winding elements are joined by means of the metal spray method (schooping). A number of elements will be connected together to get the required capacitance. The entire winding package will be incorporated within a welded stainless steel casing.

The casing is fitted with hermetically sealed bushings M12, for connection of the supply cable.

A threaded stud M10 for grounding is provided. Easy mounting will be ensured by 4 drillings, \varnothing 9.8 mm, at the bottom of the container, or by side-brackets.

This design ensures the highest safety by self-healing technology as well as by an over pressure monitoring device. In case of an internal failure, an over pressure may occur and operate a potential-free contact, which will (connected to a switching device like a contactor) disconnect the capacitor from the supply and thus protect the capacitor from bursting.

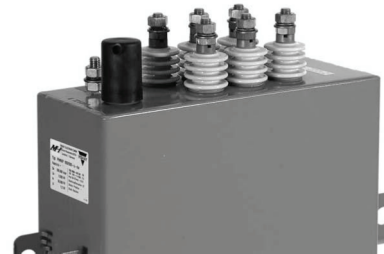
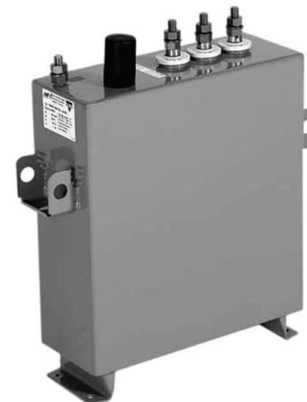
**DW-TYPE CAPACITOR,
IP00, 6 TERMINALS****DW-TYPE CAPACITOR,
IP00, 3 TERMINALS**

DW-TYPE FILTER CAPACITORS

TECHNICAL DATA	
STANDARDS	IEC 60831-1 + 2, EN 60831-1 + 2, LATEST EDITIONS
Overvoltages (in accordance with the above standards)	$U_{cn} + 10\%$ (up to 8 h daily) $U_{cn} + 15\%$ (up to 30 min daily) $U_{cn} + 20\%$ (up to 5 min, only 200 times in the life of the capacitor) $U_{cn} + 30\%$ (up to 1 min, only 200 times in the life of the capacitor) Please also refer to "Terms and Definitions".
Overcurrent (in accordance with the above standards)	$1.3 \times I_n$, $1.5 \times I_n$ with 10 % overvoltages, 15 % overcapacitance and harmonics included, continuous operation Please also refer to "Terms and Definitions". Higher currents upon request!
Tolerance on capacitance	$\pm 5\%$ (very narrow tolerances of $\pm 3\%$ upon request)
Test voltage, terminal/terminal	$2.15 \times U_{cn}$, VAC, 2 s (routine test)
Test voltage, terminal/casing	3600/7200 (\leq / $>$ 660 V) VAC, 2 s (routine test)
Inrush current	300 times rated current
Losses	< 0.50 W/kvar (without discharge resistors)
Statistical life expectancy	$> 150\,000$ operating h
Degree of protection	IP00, indoor mounting
Permitted ambient temperature	- 25/up to D (max. 55 °C)
Permitted casing temperature	Max. 65 °C (measured on top of the capacitor)
Cooling	Naturally air-cooled
Permissible relative humidity	Max. 95 %
Maximum allowed altitude	2000 m above sea level
Mounting position	Vertical or horizontal
Mounting	4 drillings, $\varnothing 9.8$ mm
Safety features	Over pressure monitoring device, self-healing
Casing	Welded stainless sheet steel casing, color RAL 7033 or Aluminum casing (ESTAdry)
Dielectric	Polypropylene film, self-healing
Filling agent	Natural oil, non-PCB, biodegradable (ESTAprop) or dry/resin filled (ESTAdry)
Terminals	Threaded studs, M12

This capacitor type will be built upon customer request. With its narrow tolerances, it is ideal for use in filter circuit applications.

Available voltage ratings are between 230 V and 1000 V. Output ratings are up to 500 kvar, depending on the voltage.

Overcurrent loading in excess of standard figures is possible.

The protection of DW-type capacitors is provided by an OVER PRESSURE MONITORING DEVICE, which must be connected to a contactor or breaker to switch off the unit in case of internal over pressure.

DIMENSIONS FILTER CIRCUIT CAPACITORS

The total output within one casing may be divided into two outputs and six bushings. Using such an “S”-type terminal arrangement may be of cost advantage when two outputs are required, but neither of them is large enough to fill up the capacitor casing.

Drawing 10
DW-type with 3 terminals

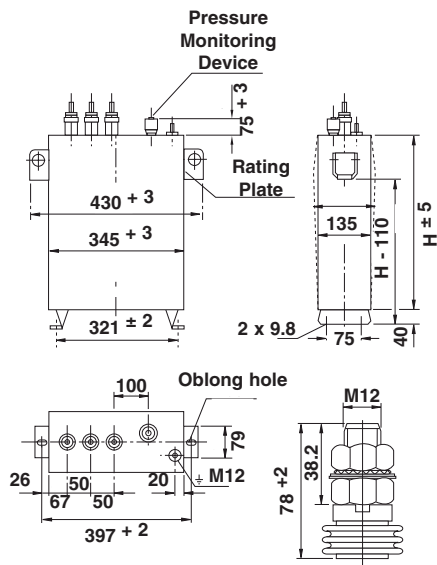

Drawing 11
DW-type with 6 terminals

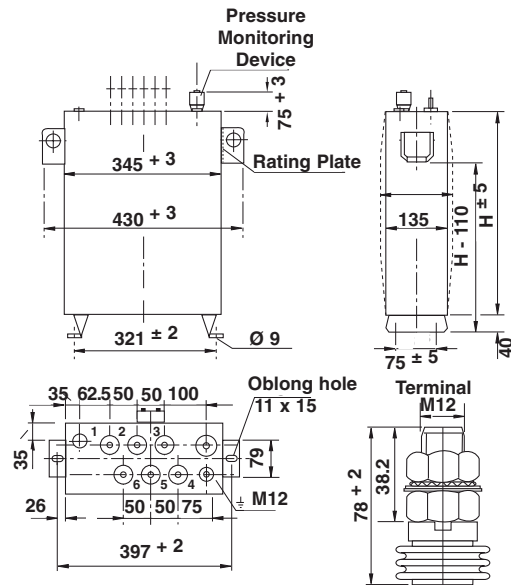

RECOMMENDED TORQUES	
TERMINAL STYLE	RECOMMENDED TORQUE
Terminals M6	3 Nm
Terminals M8	6 Nm
Terminals M10	10 Nm
Terminals M12	15.5 Nm

PRODUCTS

Low Voltage Capacitors
High Voltage Capacitors
Power Electronic Capacitors
Induction Heating Capacitors
Surge Suppressor Capacitors
Power Factor Controllers

ASIA SALES OFFICES

SINGAPORE

MUN HEAN SINGAPORE PTE LTD
51 Kim Keat Road, Unit 05-01/02
Mun Hean Industrial Building
SINGAPORE 328821
TEL: +65-6250-0522
FAX: +65-6253-6885/+65-6253-5879
EMAIL: munheansing@munhean.com.sg

MALAYSIA

MUN HEAN (MALAYSIA) SDN BHD
No.15 Jalan SS26/6 Taman Mayang Jaya
47301 Petaling Jaya
Selangor Darul Ehsan
MALAYSIA
TEL: +603-7804-2288
FAX: +603-7803-1185
EMAIL: munheanmy@munhean.com.my

HONG KONG

MUN HEAN ELECTRICAL ENGINEERING (HK) CO., LTD
Room 2304, 23/F Kodak House II
39 Healthy Street East, North Point
HONG KONG
TEL: +852-2873-1711
FAX: +852-2518-7013
EMAIL: munheanhk@munhean.com.hk

PHILIPPINES

MH POLY-ELECTROMECHS, INC.
No.15N Domingo St. Brgy. Valencia Hills,
Quezon City 1112 PHILIPPINES
TEL: +632-722-1493 / +632-727-8544
FAX: +632-725-3770
EMAIL: mhpoly@munhean.com.ph

INDONESIA

PT MUNHEAN PUMA PERKASA
Jl. Tanjung Duren Barat 1, No. 27 - 27A
Tanjung Duren Utara, Grogol, Petamburan
Jarkarta 11470, INDONESIA
TEL: +62-21-569 588 26
FAX: +62-21-567 3671
EMAIL: munheanindo@mhpp-electric.com

CHINA

MUN HEAN HONG FEI (BEIJING) TECHNOLOGY CO LTD
Room 3-2223, Gold Spring Times
No. 317, Datun Li, Chaoyang District
Beijing 100101, CHINA
TEL: +86-10-8483-9722
FAX: +86-10-8483-9721
EMAIL: mhhf@munhean.com.cn

TAIWAN

MH POWER CO., LTD
4th Fl., No.5 Alley 11
Lane 327, Chunghe District
New Taipei City, TAIWAN, R.O.C.
TEL: +886-2-2242-5501
FAX: +886-2-2246-1694
EMAIL: mhpower@hotmail.com.tw

VIETNAM

MUN HEAN VIETNAM CO., LTD
No. 37, Street 27, Block 2 Tan Phong Ward
District 7, Ho Chih Minh City, VIETNAM
TEL: +84-8-5433-3538
FAX: +84-8-5433-3539
EMAIL: munheanvn@munhean.com.vn

MYANMAR

MUN HEAN MYANMAR
No.96 Yadanar Myaing Street
Off Yagon-Insein Road (West Side)
Kamaryut Township, Yangon, MYANMAR.
TEL: +95-1-539-483
FAX: +95-1-527-355
EMAIL: mhmyanmar@munhean.com

www.munhean.com