

# NX231A Earth-fault Relay User's Guide

## A BRIEF OVERVIEW

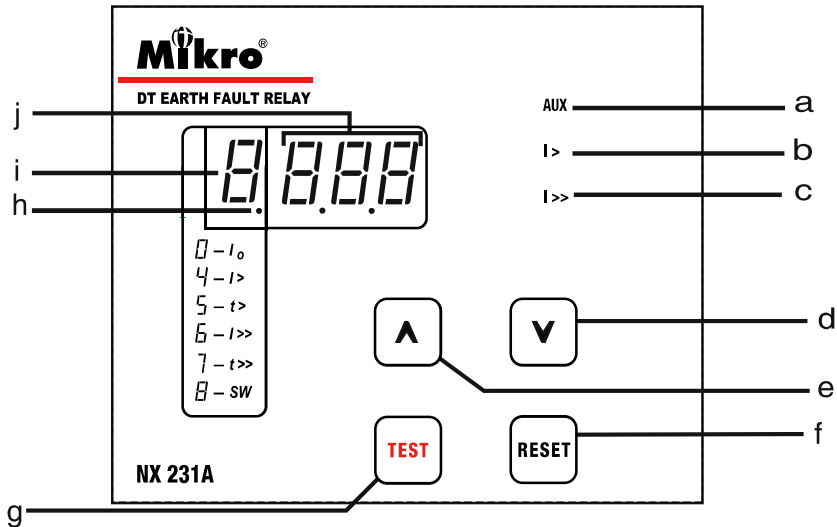

- a - Auxiliary power supply indicator
- b - Low-set start/trip status indicator
- c - High-set start/trip status indicator
- d - Down key
- e - Up key
- f - Reset key
- g - Test key
- h - DP indicator
- i - FUNCTION indicator
- j - DATA indicator

### Symbols

- I<sub>0</sub> - Earth-fault current
- I> - Low-set
- t> - Low-set delay time
- I>> - High-set
- t>> - High-set delay time
- SW - Soft switches

## 1. DESCRIPTION

The NX231A is a microprocessor based numerical earth-fault relay. It uses fundamental frequency current measurement for excellent harmonic current rejection. The relay provides two-element (low-set and high-set) earth-fault protection with definite time characteristic. The 4-digit panel display on the NX231A allows the display of present load current; recorded fault current for last tripping; and all setting of the relay.

## 2. LIGHT INDICATORS

The indicators display the status of the system as follow:

Indicator					Status
Aux	I>	I>>	FUNC	DT	
0	0	0	0	0	No Auxiliary power supply.
1	0	0	X	X	Normal condition, no tripping.
1	1	0	X	X	Low-set overcurrent triggered, time delay countdown started.
1	0	1	X	X	High-set overcurrent triggered, time delay countdown started.
1	B	0	B	B	Low-set tripped, DT LEDs show tripped value.
1	0	B	B	B	High-set tripped, DT LEDs show tripped value.
1	X	X	B	1	Programming mode.

Table 1: System Status

1 = ON    0 = OFF    X= don't care, not blinking  
B = blinking    DT = DATA    FUNC = FUNCTION

Indicator		
FUNCTION	DP	DATA
0	off	Earth fault current.
0	blink	Previous tripped current.
4	off	Low-set current setting.
5	off	Low-set delay time setting.
6	off	High-set current setting.
7	off	High-set delay time setting.
8	off	Soft switch setting.

Table 2: FUNCTION Code

Note: Under normal operating condition, The 4-digit display is off. When the RESET key is pressed, the 4-digit display will light up. The display will switch off automatically after 6 minutes if no further key is pressed.

## 3. PUSH-BUTTONS OPERATION

### a) Trip test

Press and hold the "TEST" button for 3 seconds to stimulate a trip.

Display shows "TEST", indicators I> and I>> turn "ON" when "TEST" button is pressed.

### b) Trip reset

Press the "RESET" button to reset the relay when tripped.

### c) View setting

When the relay is not under tripped condition, pressing the "RESET" button will scroll through the various functions.

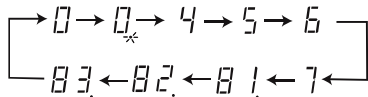

Figure 1: Scroll sequence

### d) Program setting

Only function codes from 4 to 8 can be programmed.

Step 1: Press RESET key until the function digit shows required function.

Step 2: Press the UP and DOWN key simultaneously to enter programming mode. The function digit will blink to indicates the relay is in programming

Step 3: Use the UP or DOWN key to select the desired value.

Step 4: To save the selected value, press the UP and DOWN key simultaneously again. It will exit the programming mode with the data digits displaying new setting.

To exit programming mode without saving the selected setting, press the RESET key once.

## 4. OUTPUT CONTACTS

The NX231A has two set of output contact:

- (i) CONTACT R1 - linked to trip signal.
- (i) CONTACT R2 - linked to trip or start signal.

The output contact can be programmed to be either auto reset type or manual reset type.

For auto reset type, the contact remain activated until the fault current is removed.

For manual reset type, the contact remain activated.

## 5. SOFT SWITCHES

The NX231A incorporates 3 soft switches for system configuration. When the function digit shows "8", the relay is in soft switch setting mode.

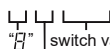

switch number (SW)

SW	SVL	System configuration
1	00	Contact R1 linked to trip signal auto reset type.
	01	Contact R1 linked to trip signal manual reset type.
2	00	Contact R2 linked to trip signal auto reset type.
	01	Contact R2 linked to trip signal manual reset type.
	10	Contact R2 linked to signal auto reset type.
	11	Contact R2 linked to signal manual reset type.
3	00	High-set disabled.
	01	High-set enabled.

Table 3: Soft switch setting

## 6. TECHNICAL DATA

### Ratings

Rated current  $I_n$  .....5 A  
 Frequency .....50 Hz or 60 Hz  
 Burden .....< 0.3 VA at  $I_n$

### Auxiliary Supply

NX231A-240A(6).....198~265 VAC  
 NX231A-110A(6).....94~127 VAC  
 Supply frequency .....50 Hz or 60 Hz  
 VA rating .....3 VA typical

### Setting Ranges

Low-set setting  $I>$ .....0.10 - 5.00 A (2%-100%)  
 Low-set definite time  $t >$  .....0.05- 99 sec  
 High-set setting  $I>>$  .....0.10 - 50.0 A (2%-1000%)  
 High-set definite time  $t>>$ .....0.05 - 2.5sec

### Outputs

Trip Contact:  
 Rated voltage .....250 VAC  
 Continuous carry .....5A ( $\cos \phi = 1.0$ )  
 Make and carry for 0.2 s .....30A

### Contact specification

Expected electrical life ..... $10^5$  operations  
 Expected mechanical life ..... $5 \times 10^6$  operations

### Indicators

Auxiliary supply .....Green LED indicator  
 Pick up .....Red LED indicator  
 Trip .....7 segment LED and red LED indicators

### Mechanical

Mounting .....Panel mounting  
 Front panel .....Standard DIN 96x96 mm  
 Approximate weight .....0.6 kg

## 7. CONNECTION DIAGRAMS

Earth Fault Relay

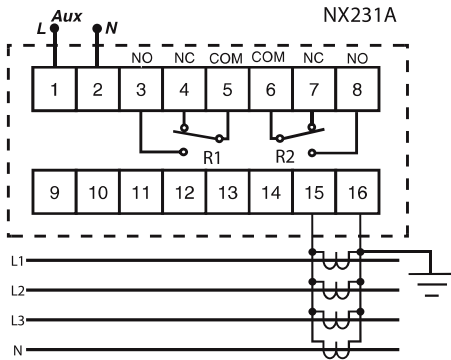

## 8. CASE DIMENSION

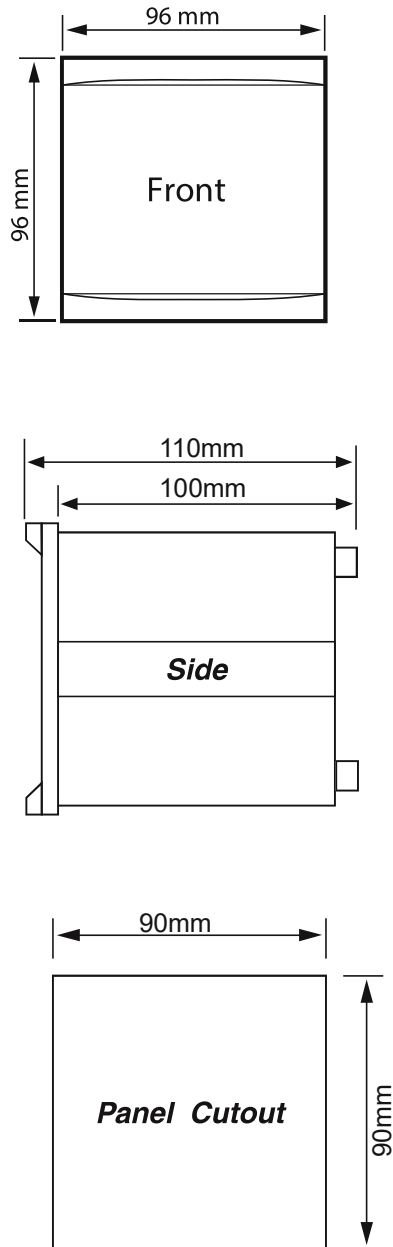

Figure 2: Case Dimension