

INDICATORS

Pre-fault alarm	Red indicator
Leakage trip delay time	Red indicator
Leakage trip	7-segment display and red indicators
Manual test trip	7-segment display and red indicators
ZCT connection fault	7-segment display and red indicators
Trip records	7-segment display
Real-time leakage current	7-segment display

ZERO-PHASE CURRENT TRANSFORMERS

To operate with Mikro's ZCT series of current transformers

MECHANICAL

Mounting.....	Standard DIN 96x96mm panel mount
Approximate weight.....	0.58kg (excluding ZCT)

9. CONNECTION DIAGRAMS

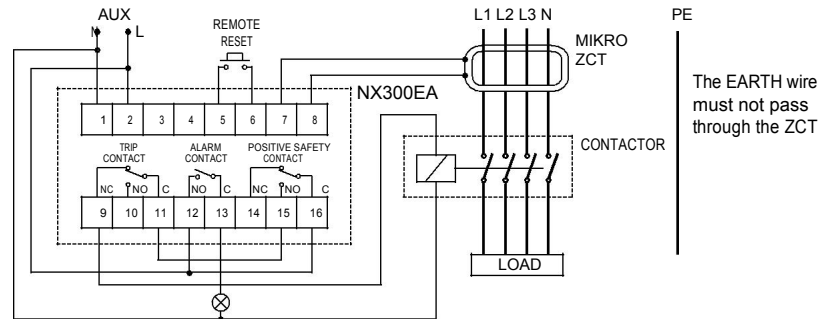
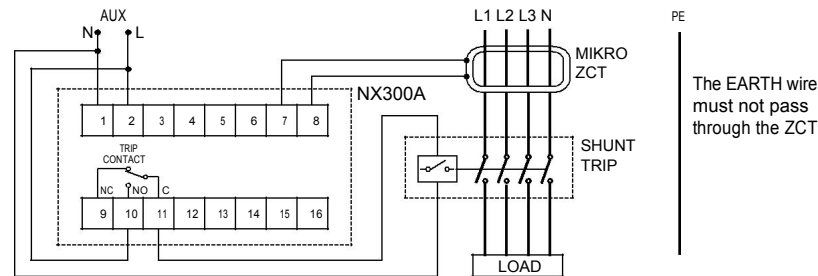

10. CASE DIMENSION

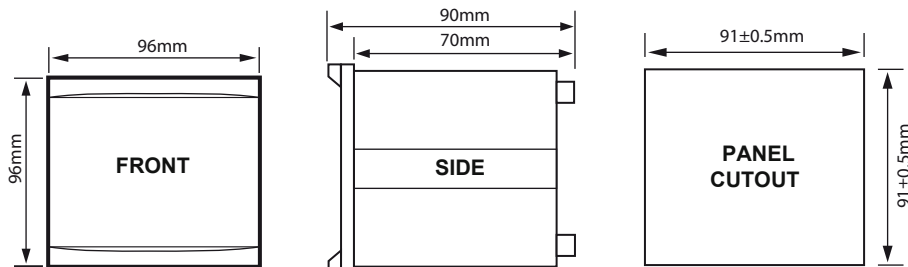

* Applicable to NX300EA series only

NX300A & NX300EA Earth Leakage Relay User's Manual

A BRIEF OVERVIEW

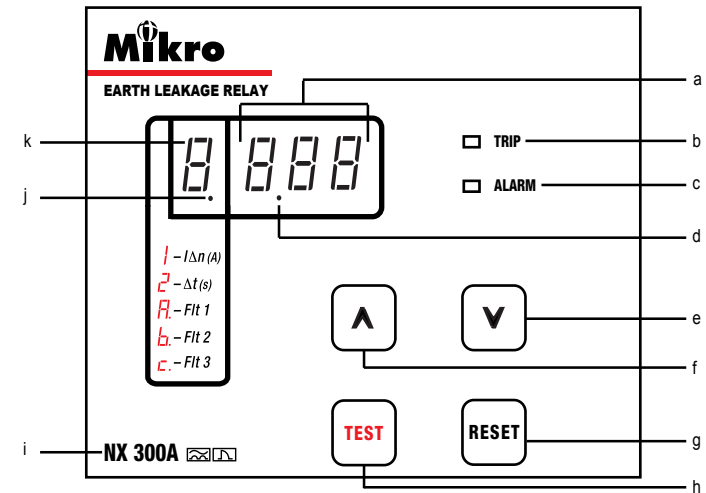

- a - DATA display
- b - Trip status indicator
- c - Alarm status indicator
- d - DP2 indicator
- e - Decrement button
- f - Increment button
- g - RESET button
- h - TEST button
- i - Model
- j - DP1 indicator
- k - FUNC display

Symbols

- $I_{\Delta n}$ - Sensitivity setting
- Δt - Time delay setting
- Flt 1 - Fault record #1 (Most recent)
- Flt 2 - Fault record #2
- Flt 3 - Fault record #3 (Oldest)

1. DESCRIPTION

The NX300A and NX300EA are microprocessors based earth leakage relays designed for measure the low-level current flowing from the live part of the installation to the earth in the absent of the insulation fault. A zero phase current transformer is connected to the relay and function as the sensor for sensing the leakage current. All conductors of the circuit to be protected shall go through the ZCT.

For better fault preventive control of the system or equipment to be protected, NX300EA series comes with a pre-fault alarm contact and a positive safety contact. The pre-fault alarm contact is activated whenever the leakage current exceed 50% of the sensitivity setting. While the positive safety contact is activated if the relay is power up and function correctly. The NX300EA series also built-in a digital input port for remotely reset the relay after leakage fault trip, manual test trip or ZCT connection fault.

2. LIGHT INDICATORS

[Trip]	[Alarm]	[FUNC]	[DP1]	[DATA]	Status
LED	LED	display	indicator	display	
0	0	0	0	0	No auxiliary supply
0	0	X	X	1	Normal condition, no tripping
0	B	X	X	X	Leakage current > 50% of the I _{Δn}
0	FB	X	X	X	Leakage current > 85% of the I _{Δn} . Trip time delay running
1	1	0	0	B	Relay tripped
0	0	1	0	1	Scroll through setting
0	0	1	1	1	Scroll through records
0	0	B	0	1	[DATA] programming mode
1	1	X	X	"Ct"	ZCT connection fault
X	X	X	X	"tSt"	Manual trip test

Table 1: Relay status displayed

1 = ON

B = Normal blink

0 = OFF

FB = Fast blink

X = Don't care

3. PUSH BUTTONS OPERATION

a. Integral Trip Test:

- Press the [TEST] button and hold for 3.5s to perform an integral test on the relay ranging from the analog sensing circuitry to output contact(s) of the relay as well as the relay indicators and display.
- During the testing process, the first 2s is to simulate the pre-fault alarm condition then follow by 1.5s testing on the trip time delay. End of time delay, relay trip.

b. Leakage Fault Trip Reset: / Manual Test Trip Reset:

- Press the [RESET] button once or through digital input port.

c. ZCT Connection Fault Reset:

- Press the [RESET] button once or through digital input port.
- Reset is inhibited if the fault is not rectify.

d. Parameters Viewing:

- When the relay is operate normal and healthy condition, press the [RESET] button to step through the various functions.
- When step through the parameters, press [RESET] button and hold for 1.5 second to jump direct to the default [FUNC].

[FUNC]	[DP1]	[DP2]	Symbols	Description
Blank	Off	Note 1		Real-time leakage current display (Default)
1	Off	X	I _{Δn}	Sensitivity setting (A)
2	Off	X	Δt	Trip time delay setting (second)
3	Off	X	Note 2	Inhibit ZCT connection fault trip
A	On	Note 1	FIt 1	Fault record #1 (Most recent)
b	On	Note 1	FIt 2	Fault record #2
c	On	Note 1	FIt 3	Fault record #3 (Oldest)

Table 2: List of [FUNC] code displayed

Note 1: If DP2 is OFF. The unit for the [DATA] displayed is in mA.

If DP2 is ON. The unit for the [DATA] displayed is in ampere (A).

Note 2: Symbol not show in front panel display

e. Parameters Setting

- Step 1: Press [RESET] button to step to desired [FUNC] or parameter.
- Step 2: Press [▲] and [▼] buttons simultaneously and hold for 1.5s to enter programming mode. The [FUNC] digit blink to indicates the relay has enter into the programming mode.
- Step 3: Press [▲] or [▼] button to increase or decrease the parameter value.
- Step 4: To save the selected value, press [▲] and [▼] buttons simultaneously and hold for 1.5s. It will exit the programming mode with [DATA] displaying the new setting.

To exit programming mode without saving the selected setting, press the [RESET] button once.

4. DIGITAL INPUT PORT *

- These digital port is for remotely reset the relay when tripped or ZCT connection fault.
- To reset the relay, make a connection between terminals 4 and 5 of the relay.

5. OUTPUT CONTACTS

Trip Contact	Activated and latch by leakage fault trip, manual test trip or ZCT connection fault
Positive Safety Contact *	Activated when the relay is power up and function correctly with no tripping.
Pre-fault Alarm Contact *	Activated when the measured leakage current > 50% of the I _{Δn} and self reset when the measured leakage current < 45% of the I _{Δn}
	Activated and latch when the relay is tripped

Table 3: Output contact description

6. RECORDS

- Record the 3 latest tripped faults current or "tSt" for manual trip test.
- The records are stored in non-volatile memory.
- To clear the entire record database:
 - Step 1: When the relay is healthy, press [RESET] button to step to most recent trip fault record or [FUNC] digit shown "A".
 - Step 2: Press [▲] and [▼] buttons simultaneously and hold for 3.5s or the [DATA] show "0". It will clear the entire fault records database.

7. TECHNICAL DATA

AUXILIARY SUPPLY

NX300A-230(6) / NX300EA-230(6).....	184~276 VAC
NX300A-110(6) / NX300EA-110(6).....	94~127 VAC
NX300A-240AD(6)/NX300EA-240AD(6).....	85~265VAC/110~340VDC
Rated frequency.....	50Hz or 60Hz
VA rating.....	3 VA typical

SETTING RANGES

Sensitivity adjustment.....	30mA, 50mA, 0.10~1.00A (step=50mA), 1.00~10.0A (step=1.00A)
Delay time adjustment.....	Instantaneous, 0.1~3.0s (step=0.1s)

RECORD

Fault record.....	3 latest trip fault current or "tSt" for manual trip test
Storage.....	Non-volatile memory

DIGITAL INPUT PORT

Remote reset.....	N.O. Dry contact
-------------------	------------------

OUTPUT CONTACTS

Contact rating.....	5A 240V ACI
Contact arrangement.....	Change over
Expected electrical life.....	50,000 at rated current
Expected mechanical life.....	5,000,000 operations