

◆DEW POINT & HUMIDITY & TEMPERATURE METER ALL IN ONE

"露點計 & 濕度計 & 溫度計"三合一

◆DEW POINT & TEMPERATURE SETTABLE

露點 & 溫度 可設定

◆LOWEST DEW POINT DISPLAY : - 69 °C

最低露點顯示 : - 69 °C

◆TO DISPLAY DP/TEMP OR HUM/TEMP SELECTABLE

可選擇顯示"露點 / 溫度" 或 "濕度 / 溫度"



■ SPECIFICATION / 規格

MODEL 型號	DPM-1	DPM-2	DPM-1-S	DPM-2-S
OUTLINE 外形	48 x 96	96 x 48	48 x 96	96x48
POWER SUPPLY 工作電壓	90~265 VAC, 50/60 Hz / 5 VA MAX.			
SENSOR 1 測溫體	K, J OR PT TYPE			
SENSOR 2 相對濕度感測器	RELATIVE HUMIDITY SENSOR <0.800VDC ~3.800VDC>			
TEMP OUTPUT 溫度控制輸出	RELAY 1c <5A/250VAC>			
DEW POINT OUTPUT 露點控制輸出	RELAY 1a <5A/250VAC>			
CONTROL METHOD 控制方式	ON / OFF			
DP/RH TRANSMITTER 露點濕度再傳送	NON		4 ~ 20 mA	
RANGE OF HUMIDITY 濕度顯示範圍	0.0% ~ 99.9%			
RANGE OF DEW POINT 露點顯示範圍	- 69°C ~ 20.0°C			
RANGE OF TEMPERATURE 溫度顯示範圍	0°C ~ 999°C			
ACCURACY OF DISPLAY 顯示精度	± (0.1 % OF F.S. + 1 DIGIT)			
SETTING RANGE 設定範圍	±99			
TEMPERATURE SHIFT 溫度修正	±9.99			
HUMIDITY SHIFT 濕度修正	±9.99			
RESPONSE TIME 反應時間	1 SEC			
MEMORY METHOD 記憶方式	EEPROM			
INSULATION RESISTANCE 絕緣強度	OVER 50MΩ			
DIELECTRIC STRENGTH 耐壓強度	OVER 2.5 KV/ 1 MINUTE			
OPERATING CIRCUMSTANCE 使用環境	20°C ~ 75°C ; 35%~85% RH			
EMC STANDARD	ESD : 8 KV AIR CHARGE < LEVEL 3>/EN-61000-4-2			
	BURST TEST : 2 KV / EN61000-4-4			

■ SELECTING OF MONITOR (顯示選擇)

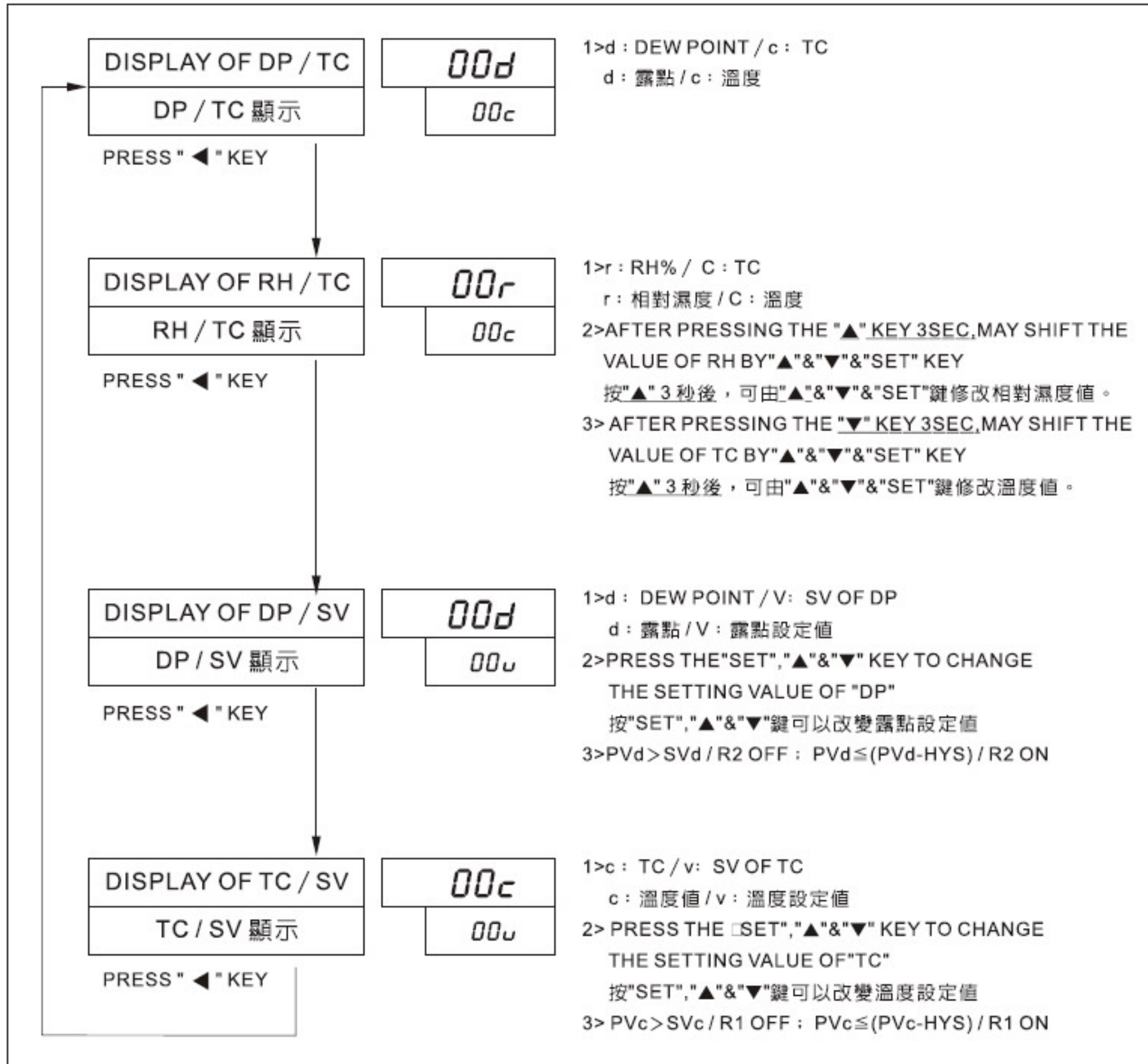

■ HOW TO SHIFT THE DISPLAY VALUE OF RELATIVE HUMIDITY (如何修正濕度顯示值)

THE DISPLAY VALUE OF RELATIVE HUMIDITY MAYBE DIFFERENT FROM THE ACTUAL VALUE, PLEASE SELECT THE RH/TC MONITOR STATUS, AFTER PRESSING THE "▲" KEY 3SEC, MAY SHIFT THE VALUE OF RELATIVE VALUE <RH> BY "▲", "▼" OR "ET" KEY.

相對濕度顯示值和實際值可能有誤差，可以在"濕度 / 溫度"監視狀態中，按"▲"鍵3秒後可以按"▲"，"▼" 或"SET"鍵修改相對濕度值。

SETTING OF PARAMETER / 參數設定

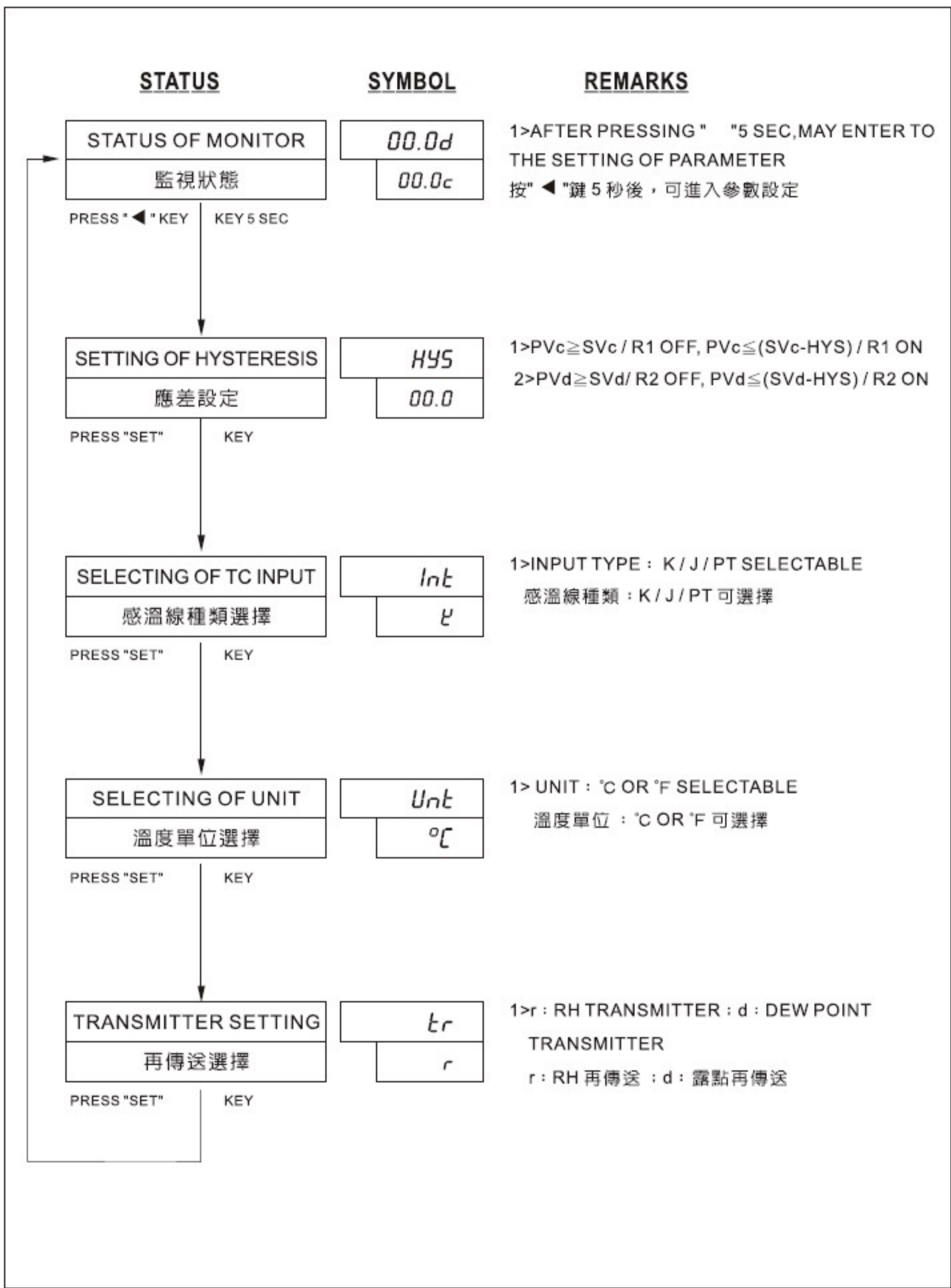

SETTING OF TRANSMITTER / 傳送設定

MONITOR SELECTING	SYMBOLS	REMARKS
STATUS OF NORMAL 監視狀態	00.0d 00c	1>d : DEW POINT ; c or F : TEMPERATURE d : 露點 c or F : 溫度
PRESS "SET" ↓ KEY 3 SEC		
SETTING OF LOCK 鎖定設定	LcL 0	1> 0 : ALL SETTING ARE UNLOCK 1 : SV SETTABLE 2 : SV SETTABLE 3 : ALL LOCK
PRESS "SET" ↓ KEY		
HI LIMIT OF TRANSMITTER 傳送上限設定	SLH 90	1> THE SLH IS CONVERTED TO "20.0" mA "SLH"轉成"20.0mA"
PRESS "SET" ↓ KEY		
LO LIMIT OF TRANSMITTER 傳送下限設定	SLL 0	1> THE "SLL" IS CONVERTED TO "4.0" mA "SLL"轉成"4.0mA"
PRESS "SET" ↓ KEY		
LO LIMIT OF DP 露點下限值設定	dPL -5l	

CONNECTION DIAGRAM / 接線圖

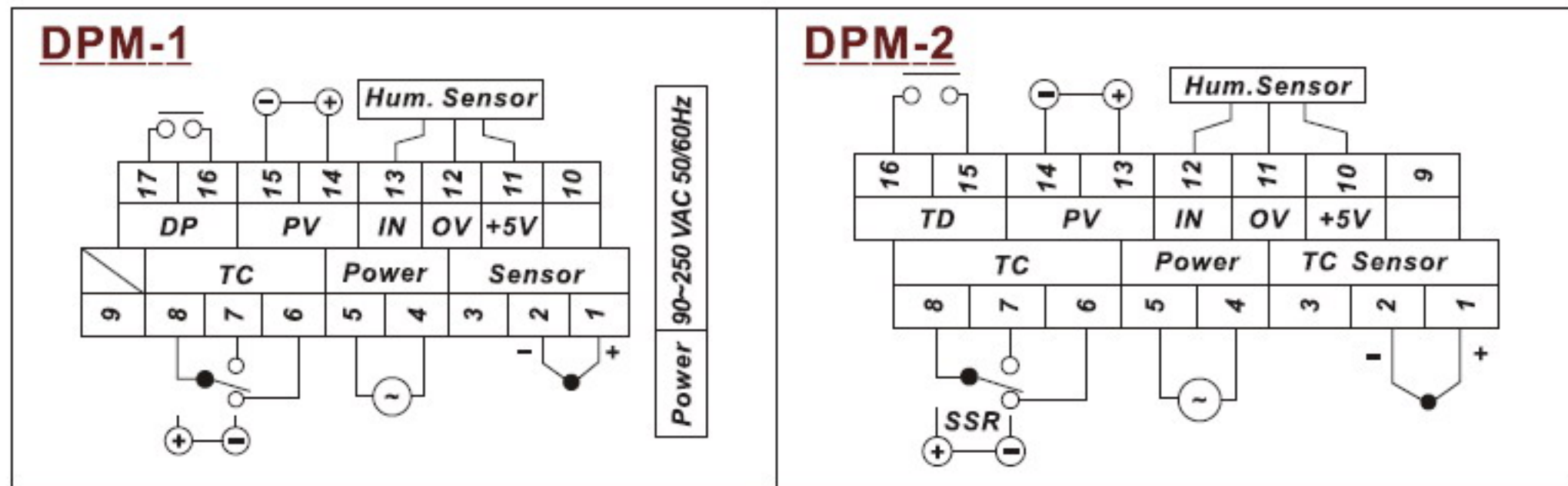

OUTLINE DIMENSION 外形尺寸圖

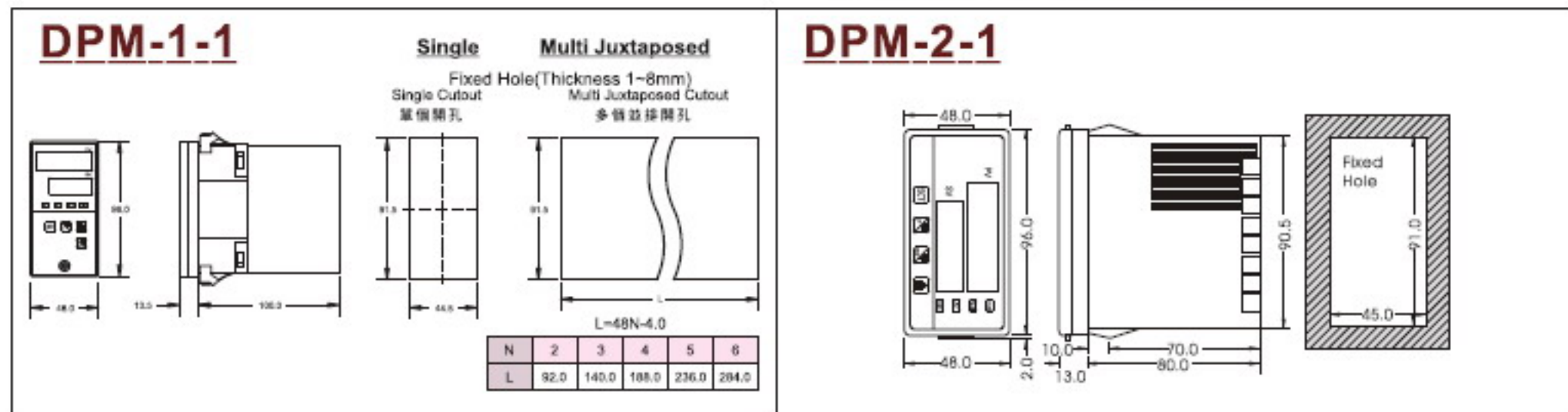

◆ LINEAR VOLTAGE OUTPUT vs %RH

相對濕度對應電壓線性輸出

◆ HIGH ACCURACY : ±2.0% RH

高精度 : ±2.0% RH

◆ FAST RESPONSE TIME : 15 SEC

快速應答 : 15 SEC

◆ STABLE & LOW DRIFT PERFORMANCE

高穩定性 & 低飄移特性

◆ CHEMICALLY RESISTANCE

抗化學腐蝕



SPECIFICATION

MODEL	型號	HS-1	HS-2
OPERATING VOLTAGE	工作電壓	4.0V DC~ 5.5VDC	
CURRENT CONSUMPTION	耗電流	200 μ A TYPICAL	
OPERATING HUMIDITY RANGE	濕度範圍	0 ~ 100% RH, NON-CONDENSING	
RH ACCURACY	RH 精度	± 2.0% RH	
RH LINEARITY	線性度	± 0.5% RH	
RH HYSTERESIS	應差	± 1.2% RH OF FS	
RH REPEATABILITY	重復性	± 0.5%	
RH RESPONSE TIME	響應時間	15 SEC IN SLOWLY MOVING AIR @ 25°C	
RH STABILITY	穩定性	± 1.0% RH TYPICAL AT 50% RH IN 5 YEARS	
CONNECTION METHOD	出線方式	M12 CONNECTOR	
OPERATING TEMPERATURE	工作溫度	- 40°C ~ 85°C	
COMMENT	注意事項	LIGHT SENSITIVE, SHIELDED FROM BRIGHT LIGHT	

CONNECTION DIAGRAM

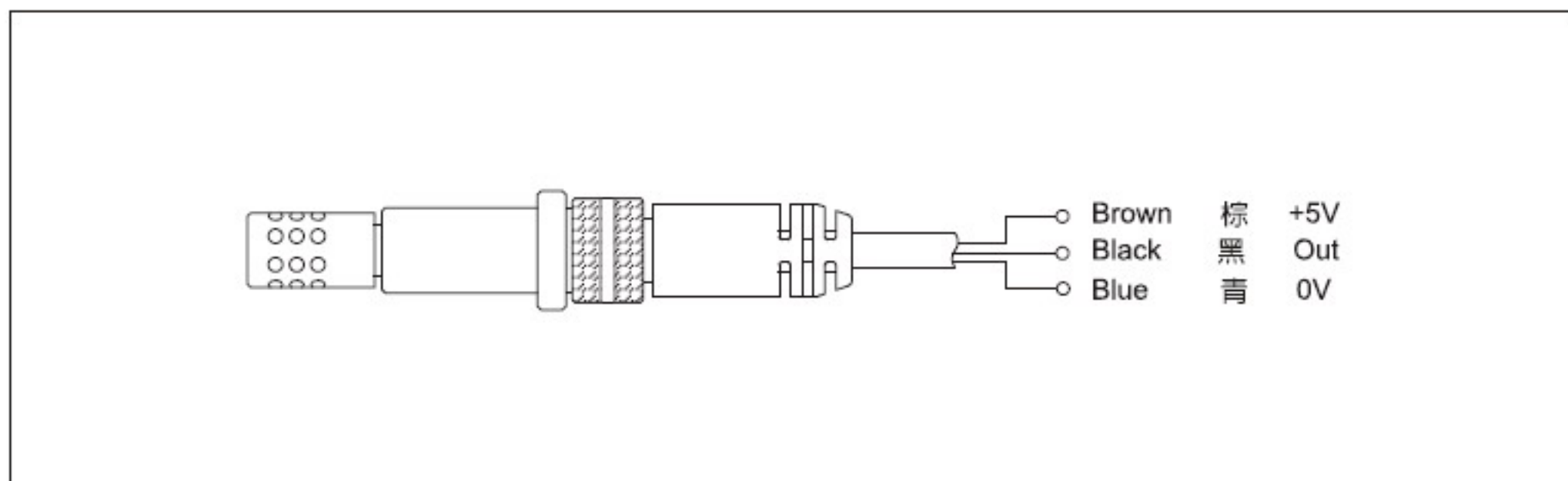

OUTLINE DIMENSION

