

Head office: SUNTREE(China)Electric Group Co., Ltd.

└ Add: Xinguang Industrial Zone, Liushi, Yueqing Zhejiang China
Tel: +86 577 6289 0205
Web: www.chinasuntree.com
Main products: Solar Accessories, such as Combiner box, DC breaker, DC isolator switch, DC spd,etc,

└ Shanghai SUNTREE Electric Co., Ltd. (Production base 1)
Add: No. 65 Haifeng Road, Baoshan District, Shanghai, China
Tel: +86 21 5161 9313
Main items: ATS, Load isolator switch, circuit breaker, etc

└ Zhejiang Nudy Electric Equipment Co.,Ltd. (production base 2)
Add: Fangdouyan Industrial Zone, Liushi, Yueqing Zhejiang China
Tel: +86 577 6178 8115
Main products: Power distribution cabinet, etc

└ Shenzhen Litto New Energy Co.,Ltd. (production base 3)
Add: Bldg. B, Bafangyuan Science Park, Sanmin Rd. No.3 Rd., Shuitian, Shiyan, Baoan, Shenzhen.
Tel: 86-755-8170 7800
Main products: on grid inverter, hybrid inverter, etc,

└ Wenzhou Xinch International Trade Co.,Ltd.
Yueqing Xinch Imp&Exp Co.,Ltd.
Add: Xinguang Industrial Zone, Liushi, Yueqing, Zhejiang Yueqing Xinch Imp&Exp Co.,Ltd, China
Tel: +86 577 6289 0205
Web: www.chinasuntree.com
E-mail: tony@chinasuntree.com
sell all products which are produced by suntree group in international market

www.chinasuntree.com

SOLAR ENERGY ACCESSORIES



Newly Launched
1500V DC Series Products

suntree
human. technology. nature

TECHNOLOGY, FOR BETTER LIFE.
SUNTREE ELECTRIC CONCENTRATES ON
INTELLIGENT TECHNOLOGY
FOCUS ON GREEN TECHNOLOGY
TO WORK OUT HARMONIOUS
LIFE WITH NATURE

ABOUT



Suntree Electric Co.,Ltd, an outstanding company in China intelligent electrical industry, a legendary growing company.

Suntree, have leading R&D and manufacture capacity. With power grid, new energy, intelligent electric, and middle & high voltage four sales business units. With production plants in Shanghai, Zhejiang, Shenzhen.

Suntree New enery business unit concentrate on new energy (Solar power generation , wind power, new energy application etc.), distribution system research and development, manufacture, sales and service. Suntree has great independent innovation ability, with many core technology, gain many patents, with ISO9001:2008, 14000, OHSAS18000 etc.

Suntree brand DC products used in Photovoltaic systems with leading technology in this area, passed CE,CB, IEC, Nemko, SAA, TUV, CCC, Gold-sun etc. Litto brand PV inverter authorized with TUV, CE, CQC, ETLQCC, AS4777, VDE-AR-4105, VDE0126-1-1, G59/2, G83/2, MEA, PEA, EN50438, EN60116, EN61727 etc. certificates.

SUNTREE

www.chinasuntree.com

Suntree new energy products including: Solar Photovoltaic distribution system (DC MCCB, DC MCB, Intelligent DC ACB, DC SPD, DC Fuse, Intelligent PV Combiner box. And Litto Brand on-grid and off-grid inverter, high frequency isolated inverter and energy storage inverter etc.

Wind power distribution system: Intelligent wind power frame circuit breaker (plateau type, salt-fog resistance type, low temperature resistance type), Moulded case circuit breaker.

New energy application: Litto brand Charging pile module.

First class products, it from advanced design concept, precise production equipment, strict testing, perfect quality assurance system, quick feedback and excellent after sales service

To provide customer with our first class products and service is our persistent goal.

Suntree company spirit "Innovation, Communication, Service, Dream", insist on "Human, technology, nature" harmonious development, according to "Win-win, win future" cooperation concept. Sincerely hope to cooperate with you to win future.

www.chinasuntree.com



CB

CE



IEC

ROHS

Nemko

NEWLY LAUNCHED

www.chinasuntree.com

1500VDC

- SISO PV ISOLATOR
- DC-PV1 DC-PV2 DC-21B
- 10A TO 32A UP TO DC1200V
- EASY TO INSTALL IP66 WATERPROOF



- DC FUSE
- SENSING EACH CURRENT, PROTECTION OTHERS ELECTRIC PARTS FOR THE FIRST TIME



SISO SWITCH

SERIES PRODUCTS

● 1500VDC PV MOUDLE CASE
CIRCUIT BREAKER



- SURGE PROTECTOR DEVICE
- IMPORTED CHIP, DURABLE PROTECTION
- EASY TO CHANGE PROTECTION MODEL

PRODUCT



01-14

DC Isolating Switch



33-40

Solar Connector And Cable
Assemblies

CATALOGUE

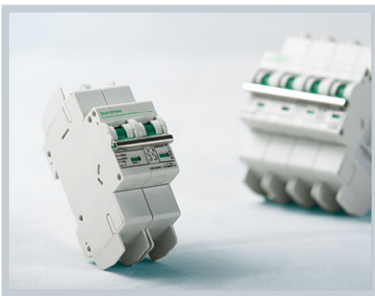

15-23

PV Solar Dedicated DC Circuit Breaker



24-30

PV Surge Protector



31-32

IP66 Distribution Enclosures



41-50

PV DC Fuse



51-54

PV Lightning Protection Cabinet



55-58

Automatic Reclosing Mini Circuit Breaker



TECHNICAL TERMS

EXPLANATION OF PV TECHNICAL TERMS

- Solar modules: Solar modules use light energy (photons) from the sun to generate electricity through the photovoltaic effect. The majority of modules use wafer-based crystalline silicon cells or thin-film cells based on cadmium telluride or silicon. The structural (load carrying) member of a module can either be the top layer or the back layer. Cells must also be protected from mechanical damage and moisture.
- Solar Cell: solar cell, or photovoltaic cell, is an electrical device that converts the energy of light directly into electricity by the photovoltaic effect. It is a form of photoelectric cell, defined as a device whose electrical characteristics, such as current, voltage, or resistance, vary when exposed to light. Solar cells are the building blocks of photovoltaic modules, otherwise known as solar panels.
- PV strings: circuit string formed by PV modules in series, used to generate specific output voltage.
- Solar panel: the unit that is composed of PV strings and other components and generates direct current.
- PV combiner box: electrical connection of PV strings of solar panels is finished in the box, where you also can find the protective equipment.
- PV power generating set: assembly of PV power generation, also called PV field.
- PV power conversion equipment: convert direct current into alternating current, also called inverter.
- Standard test condition (STC): test conditions in accordance with NF EN60904-3 (C 57-323) for PV cells and modules.
- Open-circuit voltage U_{ocSTC} : under the condition of standard test, the terminal voltage of PV modules, PV strings, and solar panels with no loads, or terminal voltage of DC side of PV power conversion equipment.
- Short-circuit current I_{scSTC} : under the condition of standard test, the short-circuit current of PV modules, PV strings, and solar panels, or short-circuit current of generating set.

Max reverse current IRM: max reverse current that the module can withstand under the condition of no any damage. This value will be provided by the manufacturer.

Note 1: this value has nothing to do with the withstand current of diversion diode, but it is the normal current flows through the PV cells in reverse direction.

Note 2: I_{scSTC} of modules whose typical value of crystalline silicon is 2~2.6 times.

Maximum power point (MPP or MPPT)

As shown in its name (track the maximum power point), in principle it can track nonlinear power generating system, such as the maximum power point of PV power generating set.

MPPT or MPPTS also embodies an inverter assembly making use of solar energy to the largest extent by optimized matching the load characteristics with that of PV devices.

Normative reference

SL7-PV series miniature DC breaker for PV power generation meets the following standards:

IEC60947-2 Low-voltage switchgear and controlgear-Part 2: Circuit-breakers, IEC60898-2 (GB 10963.2-2008) Circuit-breakers for overcurrent protection for household and similar installation - Part 2: Circuit-breakers for a.c. and d.c. operation.

Normative reference

SM1-PV series high-performance circuit breaker meets the following standards:

IEC 60947-1 (GB 14048.1) General rules
IEC 60947-2 (GB 14048.2) Circuit breakers

Normative reference

SM1G-PV series disconnecter meets the following standards:

IEC 60947-1 (GB 14048.1) General rules
IEC 60947-2 (GB 14048.2) Circuit breakers

Normative reference

SRD-PV series fuse meets the following standards:

GB13539.1-2008 Low-voltage fuses - Part 1: General requirements
GB13539.2-2008 Low-voltage fuses - Part 2: Supplementary requirements for fuses for use by authorized persons
IEC 60269-1-2006 Low-voltage fuses - Part 1: General requirements
IEC 60269-2-2010 Low-voltage fuses - Part 2: Supplementary requirements for fuses for use by authorized persons (fuses mainly for industrial application)

Normative reference

SUP2-PV surge protective device meets the following standards:

IEC 61643-31 Surge protective device

Normative reference

SGL-PV series load conversion isolating switch meets the following standards:

International standards:

\IEC 60947-1(1998) Low-voltage switchgear and controlgear-Part 1: General rules
IEC 60947-3(1999) Low-voltage switchgear and controlgear, switches, disconnectors, switch-disconnectors and fuse-combination units

International standards:

GB/T14048.1-2000 Low-voltage switchgear and controlgear-General rules
GB/T14048.3-2002 Low-voltage switchgear and controlgear-Part 3: Switches, disconnectors, switch-disconnectors and fuse-combination units

SHLX PV combiner box meets the following standards:

CGC/GF002:2010(CNCA/CTS0001-2011) Technical specifications of PV combiner box

Executive standards

This scheme is mainly prepared according to the following national or industrial standards:

DL/T5044-2004 Technical code for designing DC system of power projects
DL/T5103-1999 Design code for unattended substation of 35kV~110kV
DL/T5120-2000 DC System design code for small electric power project
GB14285-1993 Technical code for relaying protection and security automatic equipment
DL/T5136-2001 Technical code for designing of electrical secondary wiring in fossil fuel power plants and substations
JB/T5777.4 The general specification and safety requirements for D.C power supply equipment of the power system
DL/T724-2000 Specification of operation and maintenance of battery DC power supply equipment for electric power system
DL/T459-2000 Specifications of D.C supply cabinet in power system
JB/T8456-1996 Low-voltage D.C switchgear assemblies
Guodian [2000] 589 Notice about printing and issuing The twenty-five key requirements to prevent serious accident and failure in electric power operation
YDB 037-2009 Technical requirements of 240V direct current power supply system for telecommunications



Applications

SL7 series high-performance miniature DC breakers and SM1 molded case circuit breakers are mainly developed for the solar PV field. In the following applications, they are the best protective devices:

- DC reverse current protection: Protect PV modules from the danger of DC reverse current;
- AC feedback current protection: Protect PV modules from harm of feedback current caused by defective inverter AC;
- DC load isolation switch: Under load condition, it can be safely switching-off. Due to the need of malfunction or maintenance work, single PV string can be safely and selectively put into and out of use under load condition;
- Remotely trip off and send alarm.
Remote tripping function of Suntree series products can be realized by shunt release. Optional auxiliaries (switch on or off) can send out the status signals of breakers in each PV string.



Scope of application

Full range products are suitable for isolation

Suntree high-performance electrical circuit breakers can disconnect any PV string under load condition. Its rated current is up to 1250A, and its maximum working voltage is up to DC1500V.

Reliable remote control

Shunt release can be installed to remotely control electrical tripping of Suntree high-performance electrical circuit breakers. Auxiliary and alarm contacts and other optional accessories can upload clear status signals of Suntree high-performance electrical circuit breakers on each PV string.

Technical features

Protect PV modules from the danger of DC reverse current

In a PV system without fault, the current going through each PV string are equal, there is no excessive reverse current. When the system is paralleled with more than three PV strings, generally there will be a critical reverse current. In a PV string, if one or more of the PV module are damaged, the current of entire string will decrease.

This means that the normal PV string feeds higher reverse current into a failed PV string, the heat generated by the reverse current may damage PV modules and wires in each PV string.

Such damage can be avoided through installing Suntree high-performance electrical circuit breakers, when dangerous reverse current is appeared, the breaker will be tripped which can protect PV modules from damage.

If the inverter is failed, the feedback current at AC side will be fed into the DC side and damage PV modules.

Suntree high-performance electrical circuit breakers can protect each PV string from the danger of feedback current brought by fault at AC side, it can cut off the circuit before PV module is damaged.

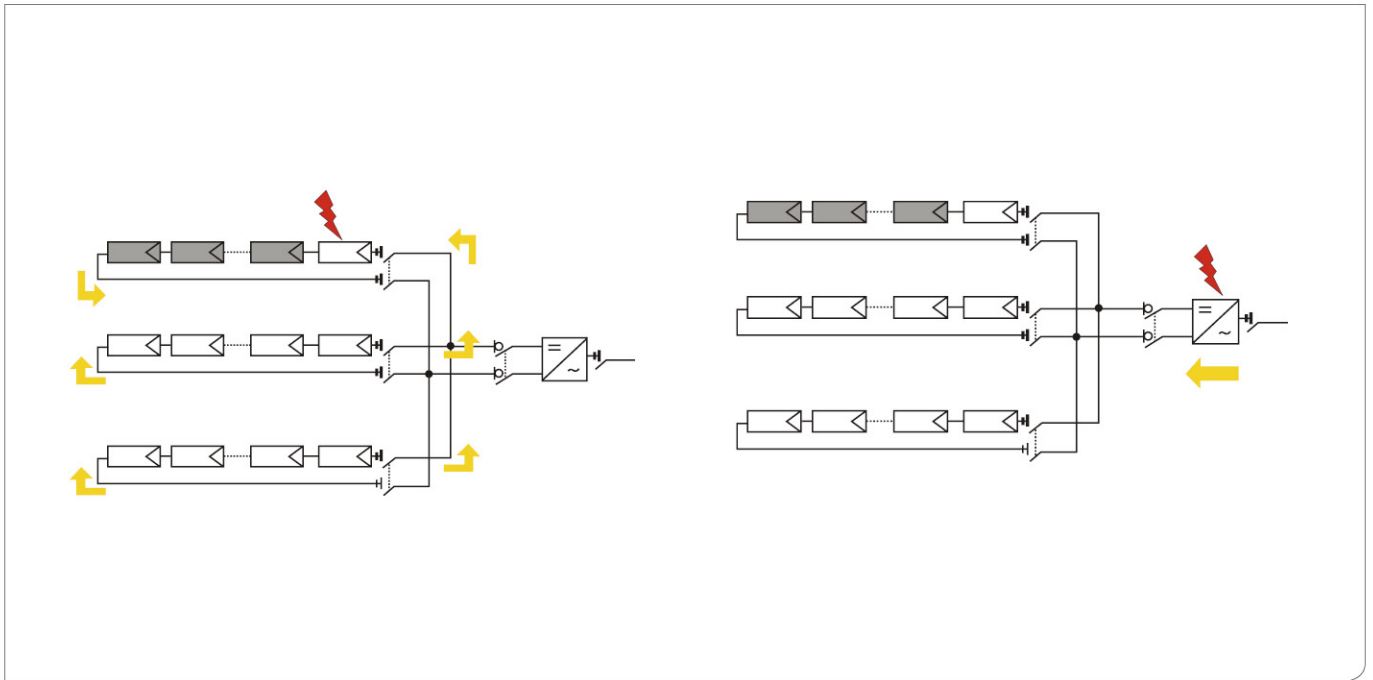

Advantages and benefits

- Rated current is up to 1250A, working voltage is up to DC1500V;
- Protect PV modules from the danger of DC reverse current;
- Protect PV modules from harm of feedback current caused by defective inverter AC;
- Each PV string can be safely and selectively put into and out of use under load condition.
- It can remotely control the disconnection of any PV string in the system, even in negative state;
- It can upload clear status signals of DC breakers in each PV string.
- Users can save the cost of series copper bars and installation, which significantly reduces the cost of manufacture.
- Internal preset series wiring can be avoided, high temperature caused by that the external series wiring does not meet the standard of GB14048.1-2006 main circuit terminal wiring standard, the circuit breaker needs to derate over 30% of its capacity, which makes it safer and more reliable.
- In accordance with the provisions in GB14048.1-2006, rated current 115A ~ 150A should choose two meters of 50mm² wire, we can calculate that the wire cooling area is 50340.48mm² which can use external series wiring if we can ensure sufficient cooling area.
- Use of copper bars can not guarantee its economical efficiency and safety.



Arc extinguishing principle of DC breaker

Arcing and arc extinguishing process of DC breaker is different from that of AC breaker. The AC arc generated by disconnection of AC breaker will go through the zero point $2f$ (f is the grid frequency) every second. It extinguishes the arc by polar effect. Only when AC breaker solved the re-strike of arc problem, it restores the recovery process of dielectric strength from conducting state back to the insulating state, It will not be elaborated.

The AC arc generated by breaking of DC breaker is constant, the greater the current is, the larger the time constant is, the more difficult to extinguish the arc.

There is no requirements for the contact of DC breaker because its performance of long-term carrying current is similar with general AC breaker. But the breaking current of DC breaker largely differs from AC breaker. The DC arc should be extinguished when contact of DC breaker is breaking. The followings are features of DC arc and measures to extinguishing DC arc:

When the contact of breaker is breaking, arc is immediately generated between static and moving contacts, which not only hinders timely breaking of the circuit, but also make contacts wear, the main problem at this time is electrical burning of contacts, on which AC and DC circuits are the same. In order to understand the arc cutting performance of DC circuit breaker, we must firstly analyze the arc generating process and the ability to extinguish the arc. When contact are breaking, at the beginning of separating of the contacts, the gap is very small, the electric field strength is great, which is easy to produce heat and strong electric field, free electrons in metal escapes from surface of the cathode to the anode. While free electrons hit the neutral gas molecules in the electric field, so it is excited and dissociated to produce positive ions and electrons, the electrons continue to move toward the anode in the strong electric field, it will also impact other neutral molecules, therefore, a large amount of ions and charged particles in the gap between contacts. These make gas conductive and forms hot electron flow, namely the arc.

After the arc is generated, there are ionization and de-ionization factors, ionization effect is due to the large amount of heat generated in the arc gap, it mainly hot ionization of gas, ely when the metal vapor on the contact surfaces gets into the arc gap, the gaseous heat ionization effect is more significant. The higher the voltage, the greater the current, which means that the larger arc power, the higher the arc zone temperature, and the stronger the arc of ionization factor. De-ionization is because the ionized positive ions and electrons will combine when they meet in space, and reform neutral gas molecules, and high temperature and intensive ions and electrons also spread towards other medium with less intensive and low temperature. As a result, the concentration of ions and free electrons decreases in the arc gap, the arc resistance increases, and the arc current is reduced, thereby hot ionization is weaken.

To extinguish the arc, it is necessary to restrain the ionization factor and strengthen the de-ionization factor, such as to pull the arc into the narrow space, to increase the distance between the moving contact and the gate films and so on, to narrow the diameter of the arc, so that the interior concentration of the ion is increased, it can enhance the proliferation and cooling effect, to stretch the arc, or to set up obstacles inside the arc to combine ions and electrons, which makes the de-ionization effect is greater than ionization effect, it will be able to extinguish the arc.



Arc distinguishing process of DC breaker

There are four processes while DC breaker completes limit test of breaking capacity:

1. Short-circuit current rises from 0 to instantaneous tripping current setting along an prospective exponential curve, the time is less than 0.5 ~ 4ms.
2. After tripping action, the contact is breaking after fixed operating time of switching mechanism, the current continues to rise, the time lasts about 1 ~ 4ms.
3. Arc are generated under cold and hot emitting effect, the arc is stretched and hot ionized and hot impacted in the arc column. The speed of gas ionization is accelerated and generated a large mount of heat and pressure, the time lasts about 0.3 ~ 6ms.
4. There is a permanent magnet or an electromagnetic coil between the static contact and moving contact of DC breaker, and it generates a magnetic field, the magnetic flux is relatively concentrated, it goes into arc extinguish space through the core plywood, and it forms layers of closed magnetic circuit with arc extinguishing plate, which quickly leads the arc through arcing ring from the contact to arc extinguishing space under a strong magnetic field.

Magnetic arcing chamber is equipped with arc deflecting cover, which is made of plastic, it is used for:

First, leading the arc be blown out vertically;

Second, making the arc to contact with the insulated wall in arcing chamber, thereby rapidly cool down the arc, enhance the de-ionization effect, improve the voltage of arc column, and force the arc to be extinguished;

Third, producing inert gas to help extinguishing arc.

Arc slit can compress the diameter of arc column and make the arc to contact closely with the wall of the slit, and to enhance the cooling and de-ionization effect. The gate file is insulated, it can derive the heat of the arc, and increase the pressures-drop of the arc column, while the films divide the arc into sections, each film is the electrode of the short arc, thus there are a plurality of anode and cathode drops, when the voltage drop at the electrode near the arc column is large enough, the voltage can not maintain the arc, and thus the arc is extinguished. It will take about 2 ~ 30ms.

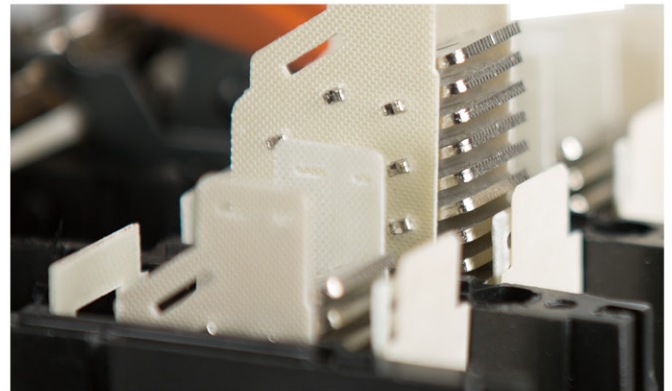

DC breaker is consisted of conductive loop, separable contacts, arc extinguishing devices, insulating parts, chassis, transmission mechanism, operation mechanism and other components.

Structure of SL7-63PV DC breaker

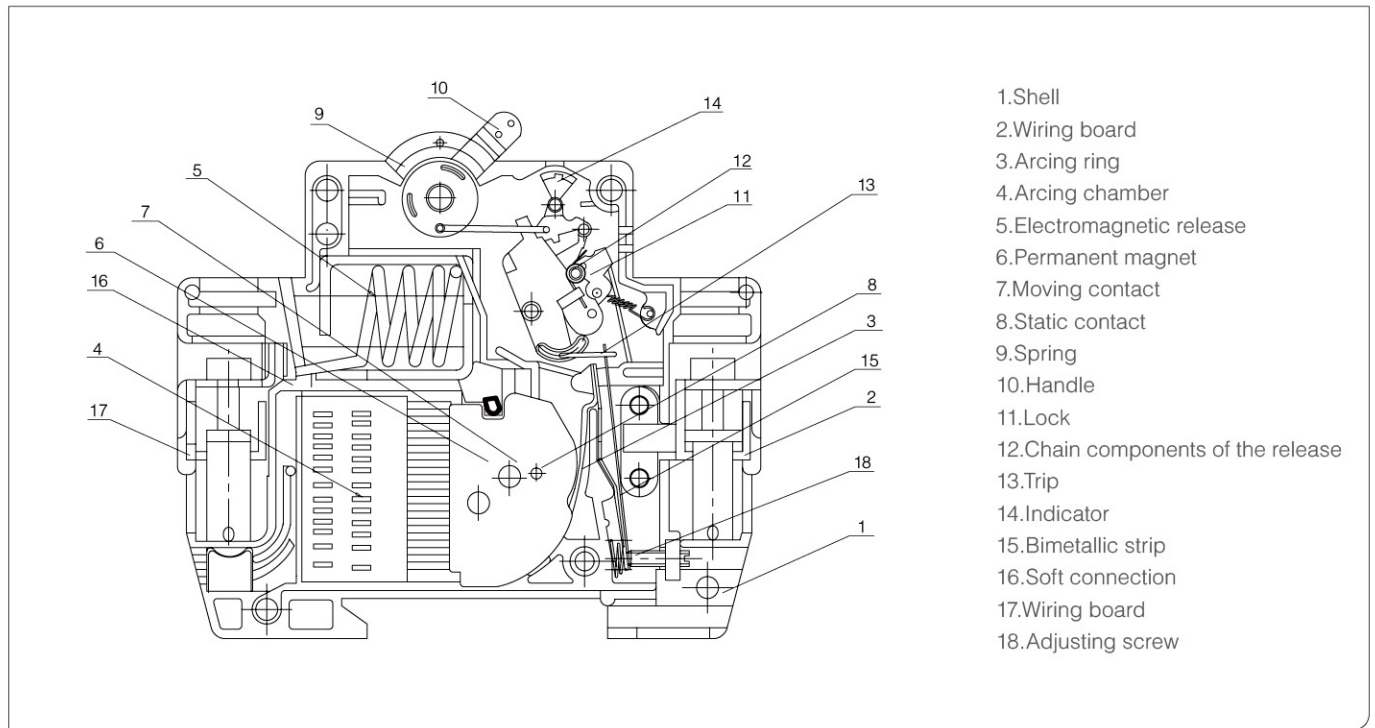

Structure of SM1-125PV and SM1-225PV molded-case DC breaker

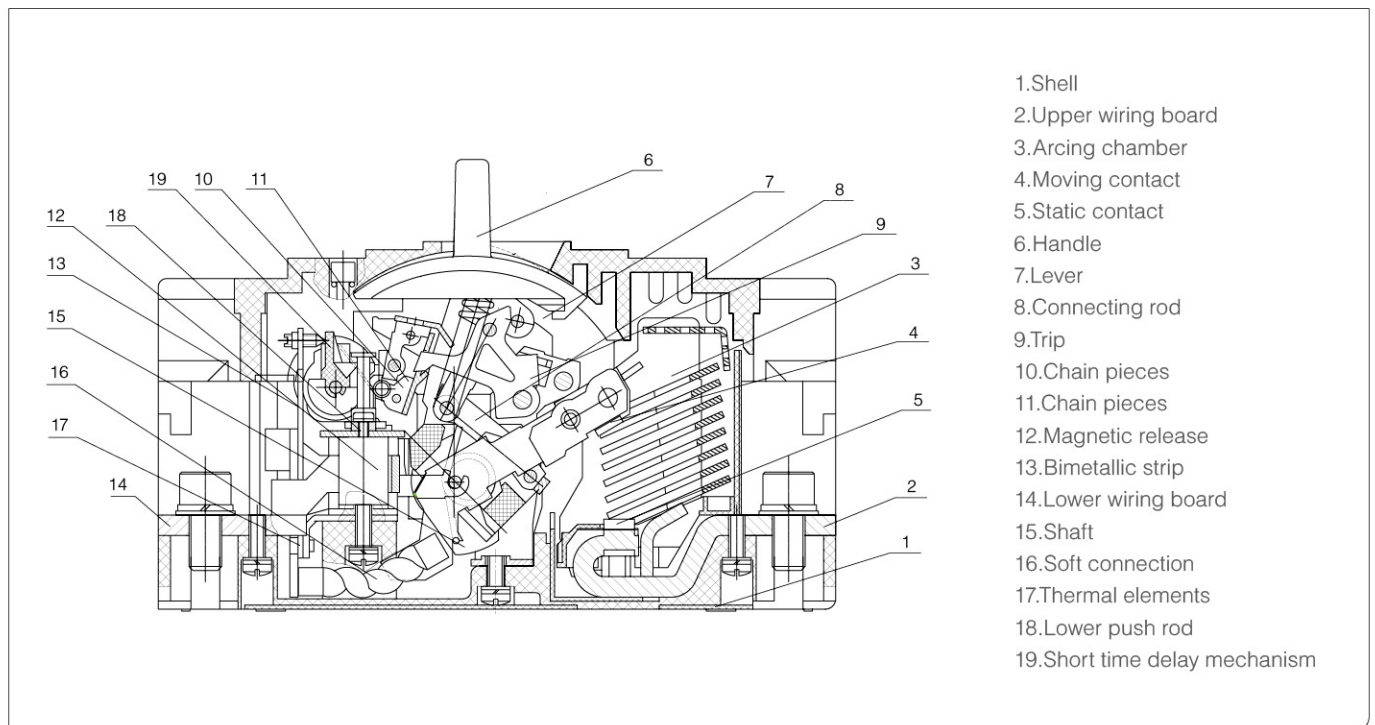

Each pole contact equipped with arc extinguish system , can eliminate arc immediately when switch off

DC ISOLATOR

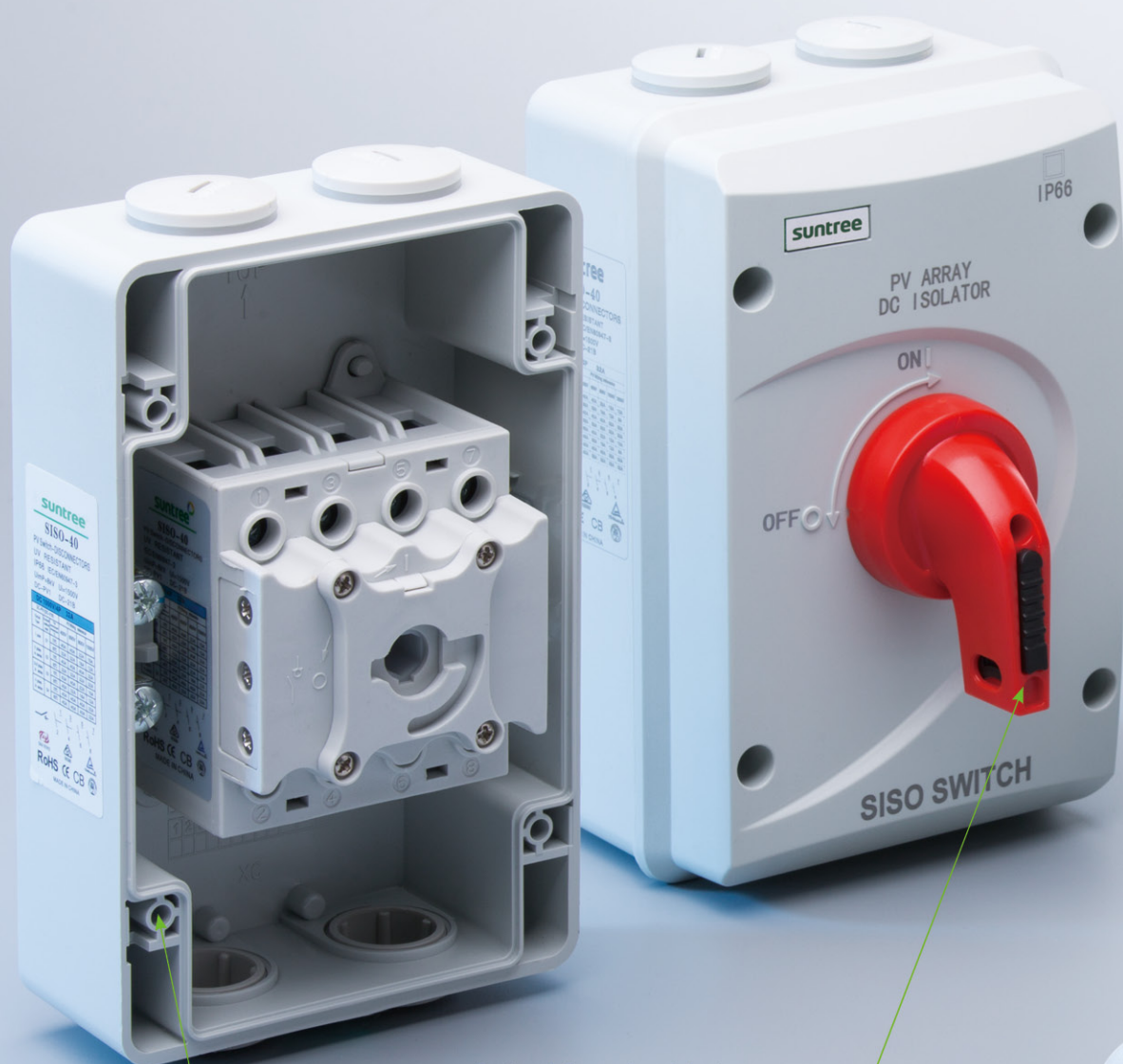

Rational Operational design prevents, reverse/ incorrect rotation

Wall-mounted design, No need to open the cover mounting, Flexible installation

SWITCH

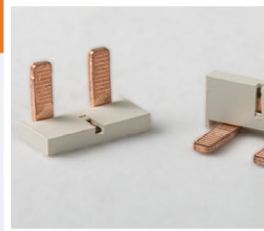

with bus-bar

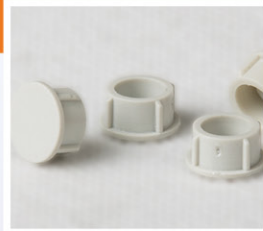

Waterproof cover



Can connect to the MC4 connectors



DC distribution PV system used disconnector

System requirements

Generally speaking, the voltage on DC side of PV system usually is higher, could be as high as 1000VDC. So we need switchgear of $U_e=1000VDC$. The branch circuit in combiner box needs protection, while the main circuit equipments in combiner box and DC cabinet need isolating function 1. Switching with load of 1000VDC or remote operation function. In addition, it needs to install switchgear 2 on DC side of inverter cabinet to switch with loads, plays a role of isolation for overhauling.

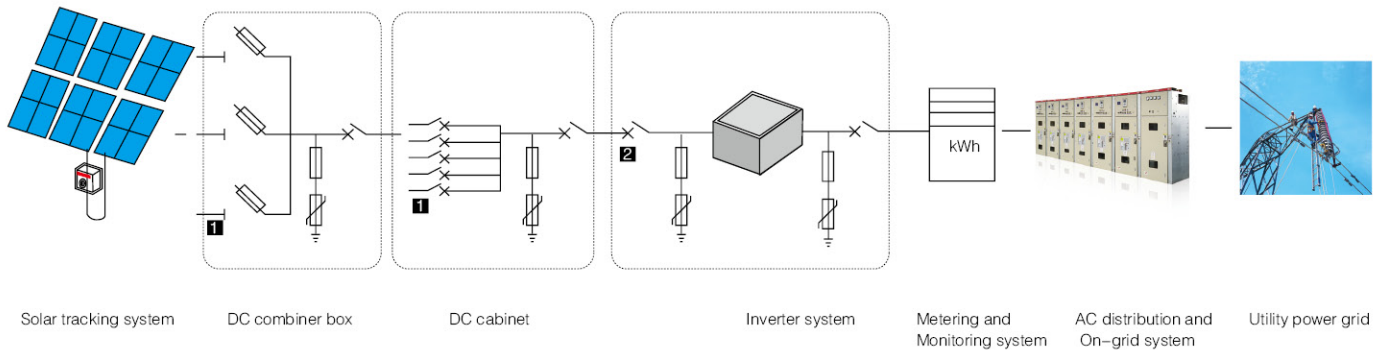

Flow chart

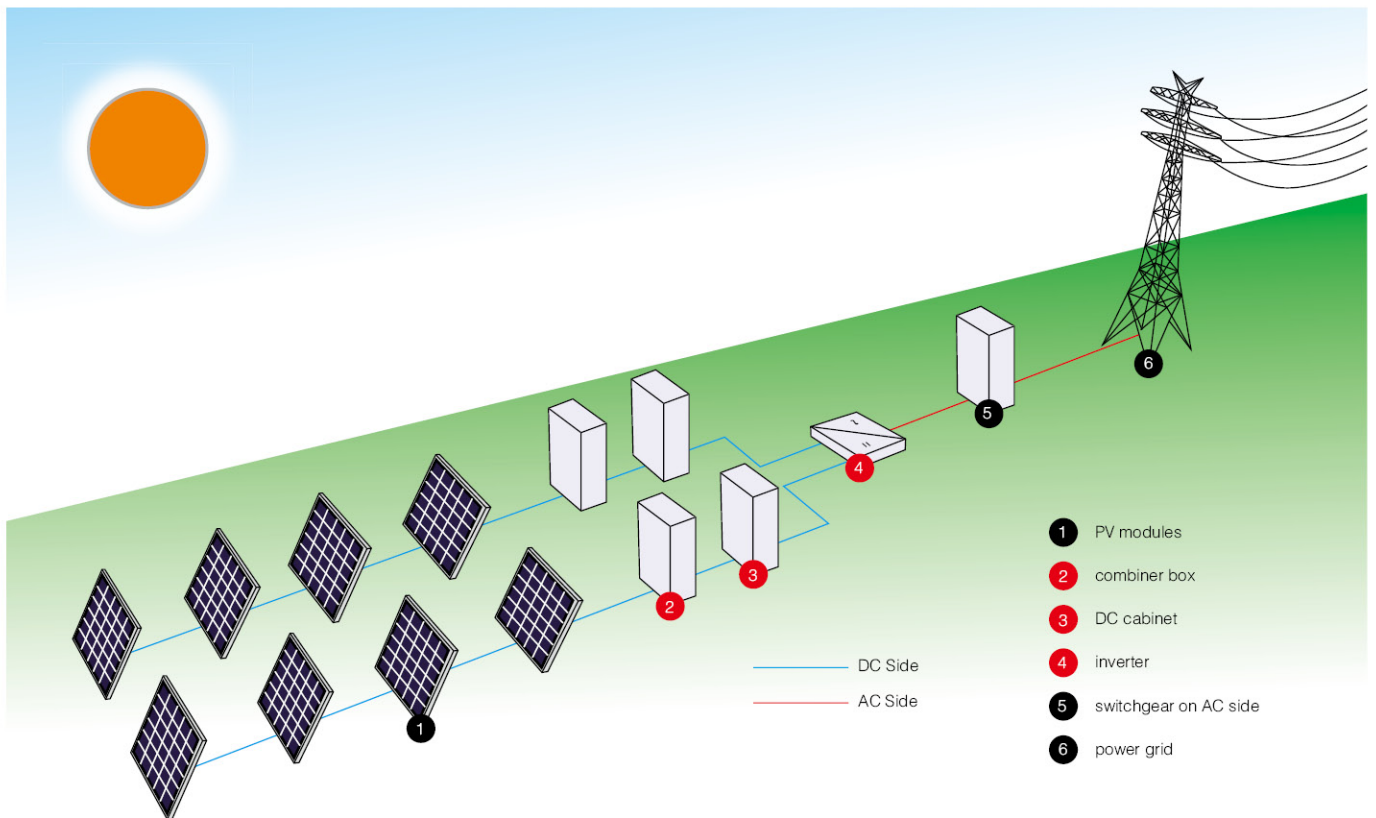



SISO-40



SISO-40

DC ISOLATING SWITCH

- UV Resistant IP66 Enclosure
- Extremely Short Power Shut Off Time Of Approx.2ms
- Lid Only Removable In “off” Position
- Earth Terminal
- IEC60947-3,AS/NZS60947.3: 2015
- DC-PV1 DC-PV2 DC-21B
- 10A To 32A UP To DC1200v
- Easy To Install



Specifications

Rated Voltage	1000VDC TO 1200VDC
IP Rating	IP66
Connection Type	M20 M25 MC4
Rated Current	10A, 16A, 20A, 25A, 32A
Working Temperature	-25°C~+85°C
Standard	IEC60947-3, AS/NZS60947.3:2015

This product passed IEC authorized Lab IP66 waterproof testing. Also our company will take simulation tests irregularly, similar to customer's using environment, to make sure this product completely conforms to IP66 protection grade

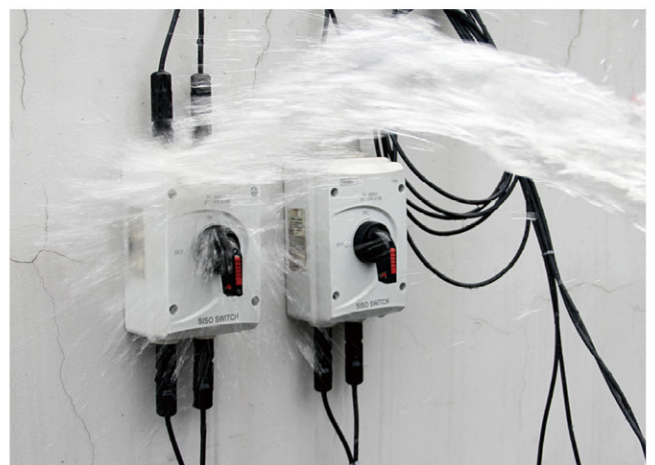

Specifications

Contact configuration	600V	800V	1000V	1200V	Poles in series	Number of strings	Type Number
	16A	16A	9A	9A	2	1	SISO-16P2
	25A	20A	11A	11A	2	1	SISO-25P2
	32A	23A	13A	13A	2	1	SISO-32P2
	29A	16A	9A	9A	2	1	SISO-16P2H
	45A	20A	11A	11A	2	1	SISO-25P2H
	50A	23A	13A	13A	2	1	SISO-32P2H
	16A	16A	9A	9A	2	2	SISO-16P4
	25A	20A	11A	11A	2	2	SISO-125P4
	32A	23A	13A	13A	2	2	SISO-32P4
	16A	16A	16A	16A	4	1	SISO-16P4S
	25A	25A	25A	25A	4	1	SISO-25P4S
	32A	32A	32A	32A	4	1	SISO-32P4S
	16A	16A	16A	16A	4	1	SISO-16P4B
	25A	25A	25A	25A	4	1	SISO-25P4B
	32A	32A	32A	32A	4	1	SISO-32P4B
	16A	16A	16A	16A	4	1	SISO-16P4T
	25A	25A	25A	25A	4	1	SISO-25P4T
	32A	32A	32A	32A	4	1	SISO-32P4T

1500V DC voltage require customized

Contact Configuration

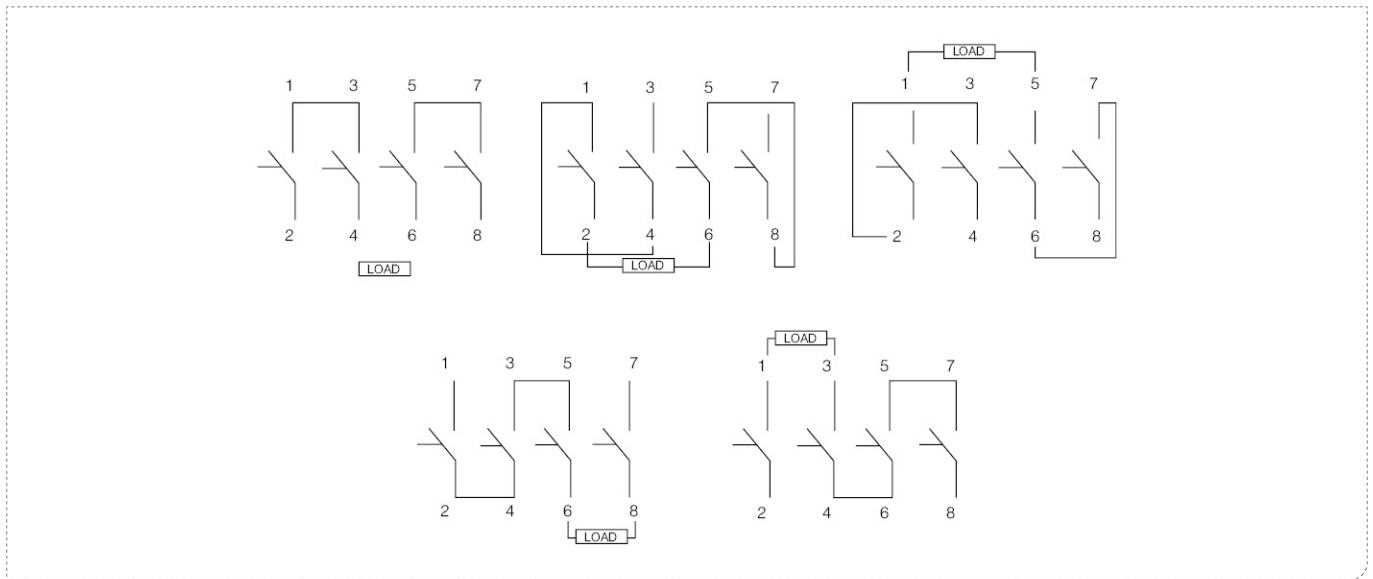

Dimensions(mm)

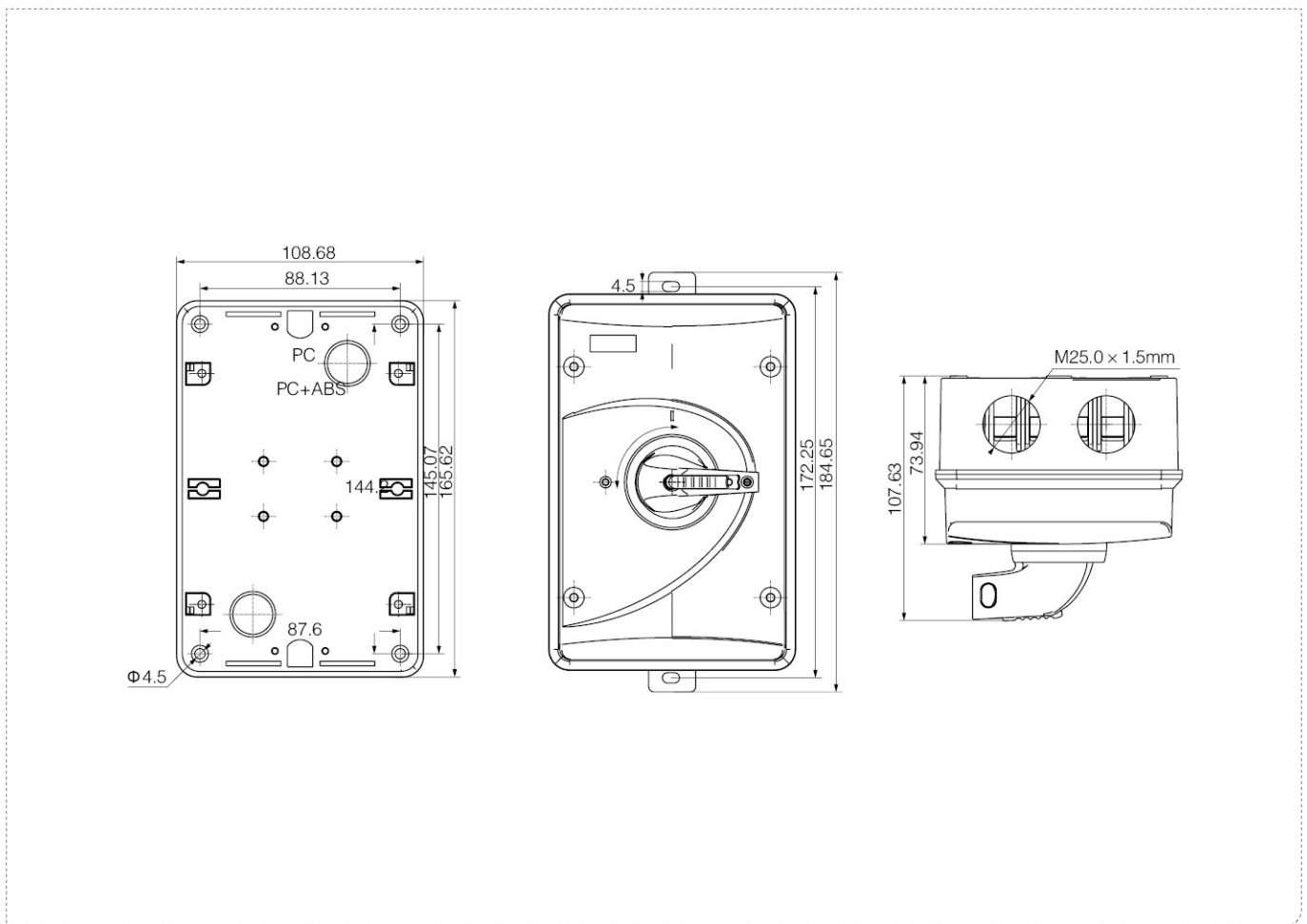



Main Switch for DIN Rail Mounting

- DIN rail mounting
- Extremely short power shut off time of approx. 3ms
- 2 poles and 4 poles available
- IEC60947-3 standard
- DC21B: 16A, 25A and 32A up to 1500V DC



Specifications

Contact configuration	600V	800V	1000V	1200V	Poles In series	Number of strings	Type Number
	16A	16A	16A	9A	2	1	SISO.2-16 D2
	25A	25A	20A	11A	2	1	SISO.2-25 D2
	32A	32A	23A	13A	2	1	SISO.2-32 D2
	29A	29A	16A	9A	2	1	SISO.2-16 D2H
	45A	45A	20A	11A	2	1	SISO.2-25 D2H
	58A	58A	23A	13A	2	1	SISO.2-32 D2H
	16A	16A	16A	9A	2	2	SISO.2-16 D4
	25A	25A	20A	11A	2	2	SISO.2-25 D4
	32A	32A	23A	13A	2	2	SISO.2-32 D4
	16A	16A	16A	16A	4	1	SISO.2-16 D4S
	25A	25A	25A	25A	4	1	SISO.2-25 D4S
	32A	32A	32A	32A	4	1	SISO.2-32 D4S
	16A	16A	16A	16A	4	1	SISO.2-16 D4B
	25A	25A	25A	25A	4	1	SISO.2-25 D4B
	32A	32A	32A	32A	4	1	SISO.2-32 D4B
	16A	16A	16A	16A	4	1	SISO.2-16 D4T
	25A	25A	25A	25A	4	1	SISO.2-25 D4T
	32A	32A	32A	32A	4	1	SISO.2-32 D4T

1500V DC voltage require customized

Main Switch for DIN Rail Mounting

Switching Configurations

Type	2-pole	2-pole 4 paralleled poles	4-pole	4-pole with Input on top output bottom	4-pole with Input and output bottom	4-pole with Input and output on top
SISO.2-16	2	2H	4	4S	4B	4T
SISO.2-25	2	2H	4	4S	4B	4T
SISO.2-32	2	2H	4	4S	4B	4T
Contacts Wiring graph						
Switching example						

Dimensions(mm)

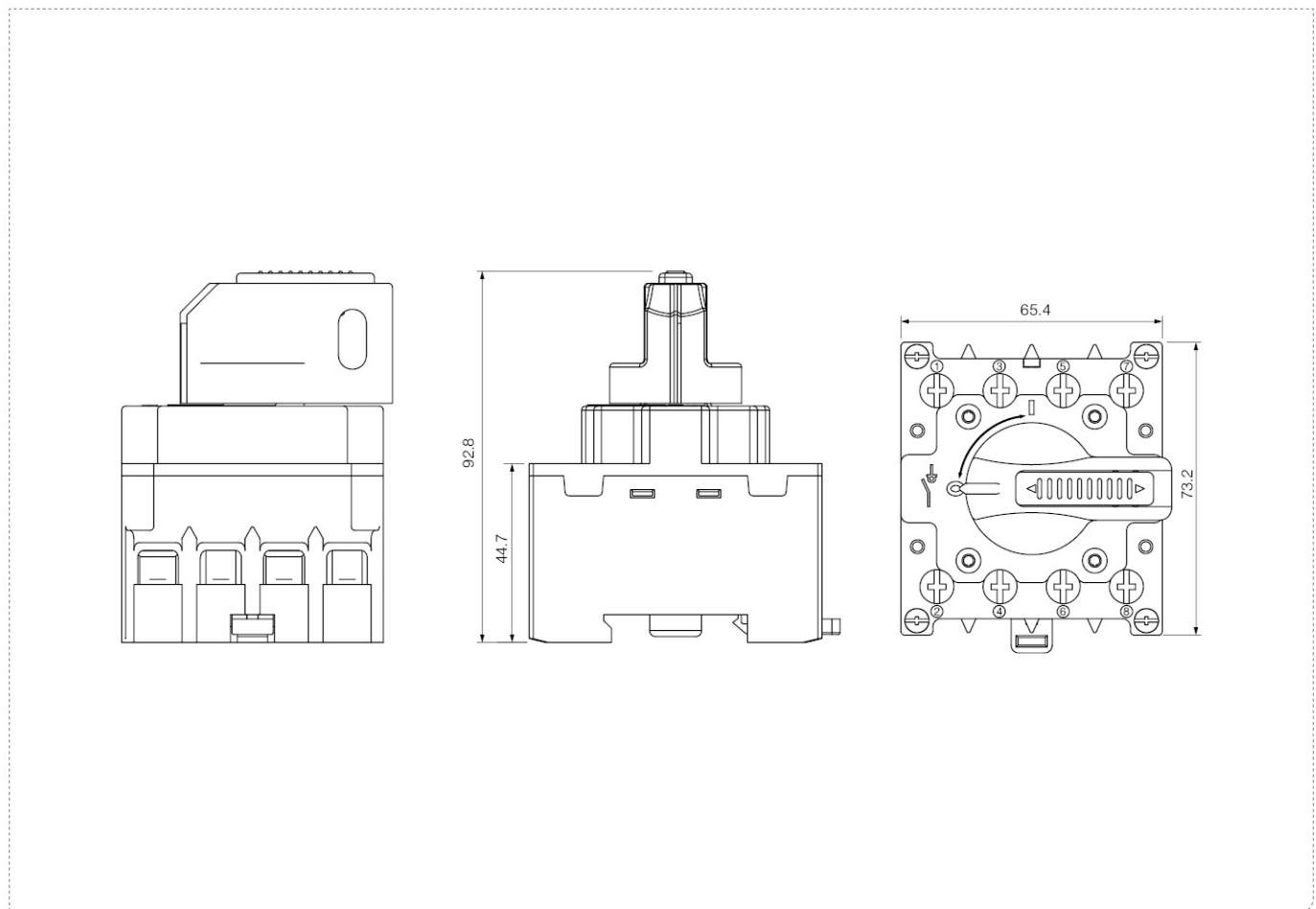



arc extinguish system, non-polarity

The handle connecting rod material you can choose stainless steel, or plastic materials

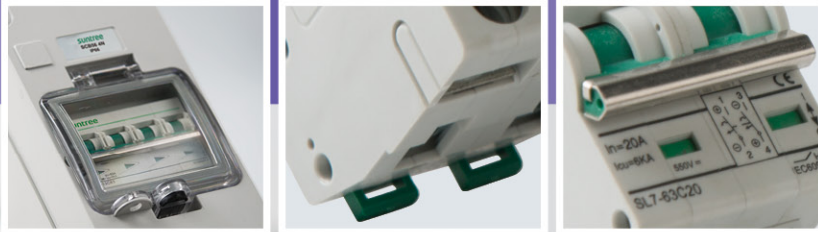

Busbar can be set up in advanced, nice looking and practical



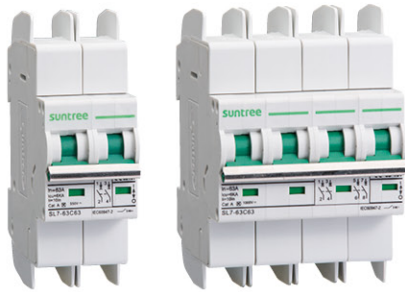

SL7 Non-Polarity DC circuit breaker

SL7 PV DC breaker supplementary protectors are designed to provide overcurrent protection within appliances or electrical equipment, where a branch circuit protection is already provided or not required. Devices are designed for direct current (DC) control circuit applications.



Specifications

SL7 PV Series Circuit Breaker		SL7-63			
Frame degree rated current (A)		63			
Electrical performance					
Ue Rated operating voltage (V DC)		2P: DC440V DC550V DC800V 4P:DC800V DC1000V DC1200V			
Rated Current In (A)		6-10-16-20-25-32-40-50-63			
Rated insulation voltage Ui (V DC)		2P: 800V 4P: 1200V			
Rated Impact voltage Uimp (kV)		4			
Ultimate breaking capacity Icu (kA)		6	6	6	6
Run breaking capacity Ics (%Icu)		75%	75%	75%	75%
Curve type		C			
Trip type		Thermal-magnetic			
MECHANICAL	Actual average value	20000			
	Standard value	8500			
ELECTRIC	Actual average value	2500			
	Standard value	1500			
Control and indication					
Shunt release (SHT)		Option			
Undervoltage release (UNT)					
Auxiliary contact (AX)					
Alarm contact (AL)					
Connection and installation					
Wiring capacity (mm ²)		In≤32A, 1~25 mm ² , I≥40A, 10~35mm ²			
Ambient temperature (°C)		-20~70			
Altitude		≤2000			
Relative humidity		≤95%			
Pollution Level		3			
Installation Environment		No obvious shock and vibration			
Installation category		Class III			
Installation		DIN Standard rail			
Dimensions(W)x(H)x(Deep)	W	17.5	35	52.5	70
	H	80	80	80	80
	Deep	71	71	71	71
Weight (kg)		0.12	0.24	0.36	0.48

Dimensions(mm)

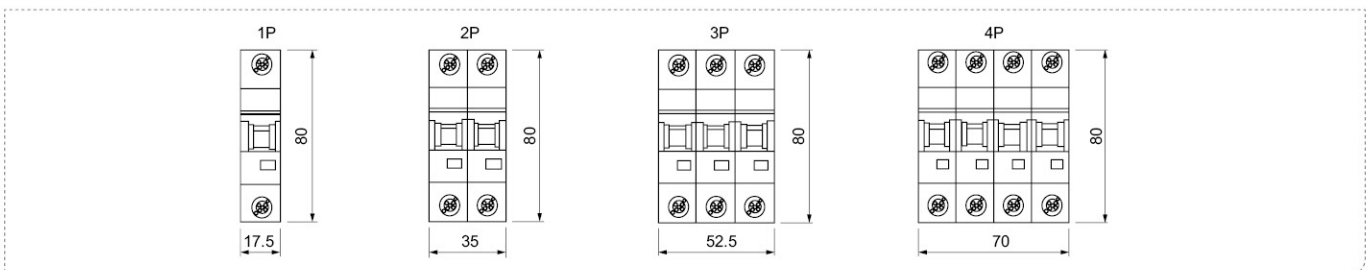

Wiring diagram

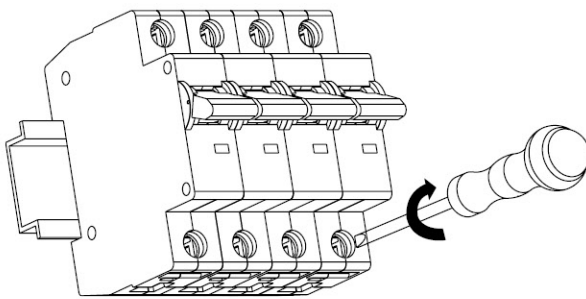
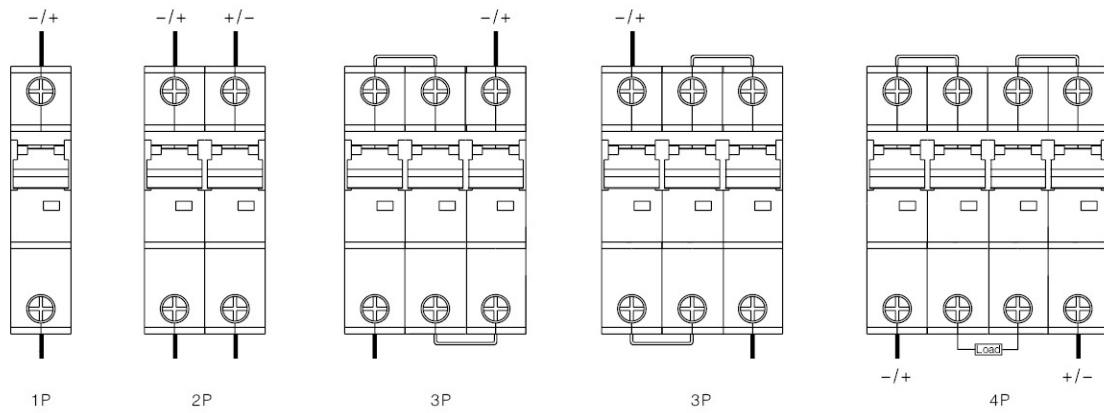

Rated current (A)	Sectional area of wire(mm ²)	Tightening torque of connecting wire(N.m)
1、2、3、4、5、6	1	Both the power side and load side are 2.0
10	1.5	
16、20	2.5	
25	4	
32	6	
40、50	10	
63	16	

Installation diagram

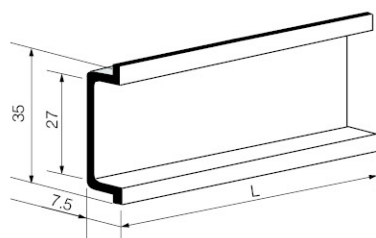

TH35-7.5 Mounting Din-Rail

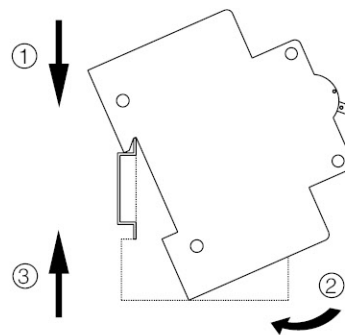



SL7 Polarity DC circuit breaker

SL7 PV DC breaker supplementary protectors are designed to provide overcurrent protection within appliances or electrical equipment, where a branch circuit protection is already provided or not required. Devices are designed for direct current (DC) control circuit applications.



Specifications

SL7 PV Series Circuit Breaker		SL7-63			
Frame degree rated current (A)		63			
EI					
Ue Rated operating voltage (V DC)		2P: DC440V DC550V DC800V 4P:DC800V DC1000V DC1200V			
Rated Current In (A)		6-10-16-20-25-32-40-50-63			
Rated insulation voltage Ui (V DC)		2P: 800V 4P: 1200V			
Rated Impact voltage Uimp (kV)		4			
Ultimate breaking capacity Icu (kA)		6	6	6	6
Run breaking capacity Ics (%Icu)		75%	75%	75%	75%
Curve type		C			
Trip type		Thermal-magnetic			
MECHANICAL	Actual average value	20000			
	Standard value	8500			
ELECTRIC	Actual average value	2500			
	Standard value	1500			
Control and indication					
Shunt release (SHT)		Option			
Undervoltage release (UNT)					
Auxiliary contact (AX)					
Alarm contact (AL)					
Connection and installation					
Wiring capacity (mm ²)		In≤32A, 1~25 mm ² , I≥40A, 10~35mm ²			
Ambient temperature (°C)		-20~70			
Altitude		≤2000			
Relative humidity		≤95%			
Pollution Level		3			
Installation Environment		No obvious shock and vibration			
Installation category		Class III			
Installation		DIN Standard rail			
Dimensions(W)x(H)x(Deep)	W	17.5	35	52.5	70
	H	80	80	80	80
	Deep	71	71	71	71
Weight (kg)		0.12	0.24	0.36	0.48

Dimensions(mm)

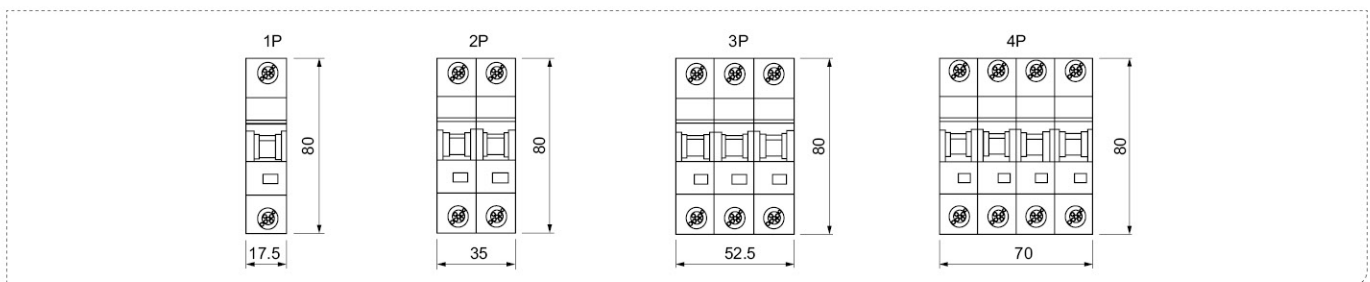

Wiring diagram

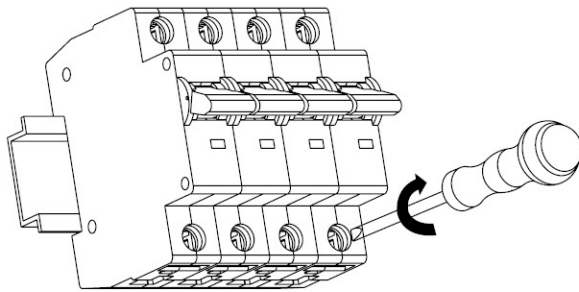
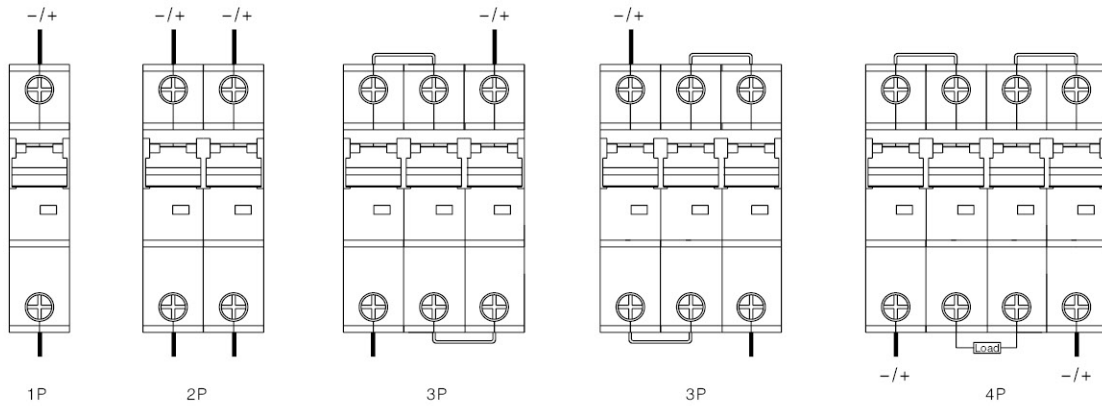

Rated current (A)	Sectional area of wire(mm ²)	Tightening torque of connecting wire(N.m)
1、2、3、4、5、6	1	Both the power side and load side are 2.0
10	1.5	
16、20	2.5	
25	4	
32	6	
40、50	10	
63	16	

Installation diagram

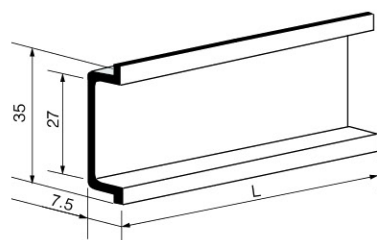

TH35-7.5 Mounting Din-Rail

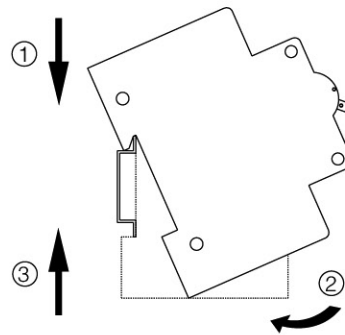



SM8-250HPV PV Specially Used DC molded case circuit breaker

SM8-250HPV series photovoltaic special DC molded case circuit breaker is suitable for DC grid circuit with rated voltage up to DC1500V and rated current of 250A. DC circuit breaker has overload long delay protection, short circuit instantaneous protection function, used to distribute electric energy and protect circuit and the power supply equipment is protected from the danger of overload, short circuit, etc.

The operating mechanism of the DC circuit breaker has the functions of quick closing and fast reading segmentation, compact structure, small size and convenient use.



Specifications

name	model	Attachment code	Attachment installation location	Control voltage
Auxiliary contact	AX	250PV	-	-
Alarm contact	AL	250PV	-	-
Shunt release	SHT	250HPV	right side installation	DC24V/AC230V/AC400V

The main technical parameters

Product number	SM8-250HPV / 2 1000V SM8-250HPV / 2 1200V	SM8-250HPV / 3 1500V
product name	PV DC MCCB PV DC MCCB	
Rated operating voltage Ue	DC1000V DC1200V	DC1500V
Rated insulation voltage Ui	1500V	1500V
Rated impulse voltage Uimp	12kV	12kV
Number of poles	2	3
Trip unit type	Thermomagnetic(Not adjustable), TMD Fixed	
Rated ultimate short-circuit segmentation capability Icu	Ue1200v 10kA Ue1000v 16kA	Ue1500v 20kA
Running segmentation capability Ics	Ue1200v 7.5kA Ue1000v 12kA	Ue1500v 15kA
Protective function	Long delay protection Ir	1In
	Instantaneous protection Ii	5In
Dimensions W×H×D	90×200×86mm	135×200×86mm

Thermal protection

Serial number	Experimental current	I/Ir	Appointed time	Initial state
1	Conventional non-tripping current	1.05	$>1h(I_n \leq 63A)$	Cold state
			$>2h(I_n > 63A)$	
2	Conventional discharge current	1.3	$\leq 1h(I_n \leq 63A)$	After the test according to the serial number 1
			$\leq 2h(I_n > 63A)$	

Wiring diagram

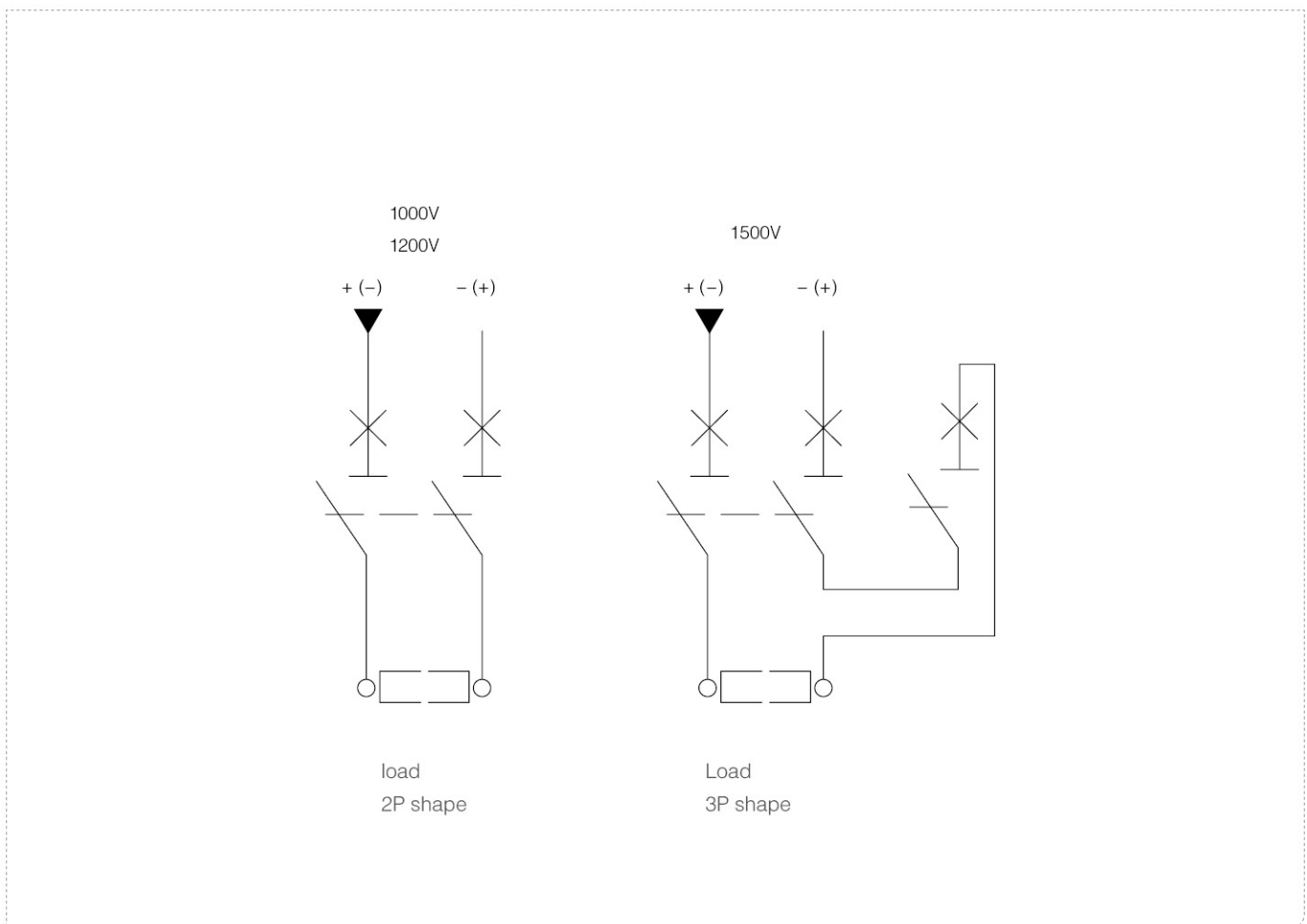

Shape and Installation Dimensions(mm)

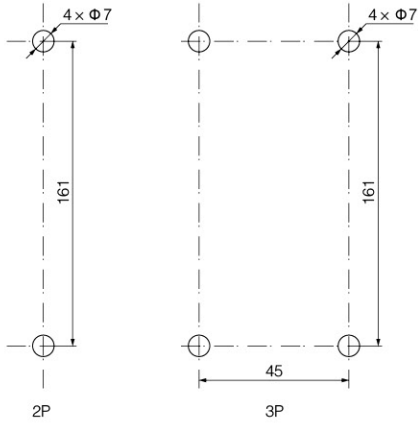
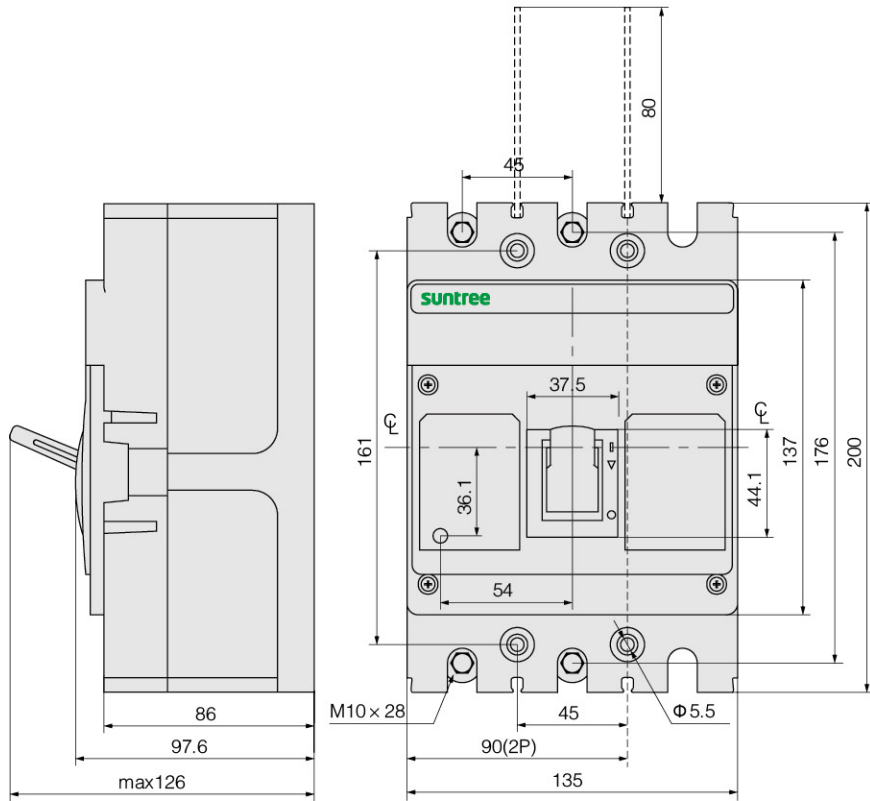

Tolerance Table

Base size		Tolerance range
>	<	
0	30	± 0.2
30	50	± 0.3
50	80	± 0.5
80	120	± 0.6
120	180	± 0.7
180	250	± 0.8
250	315	± 1.0

PV SURGE PROTECTOR

The handle connecting rod material you can choose stainless steel, or plastic materials

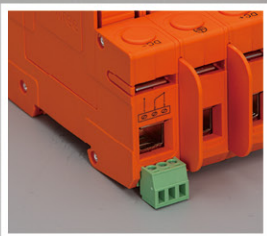

Lightning and surge protection for PV systems installed on buildings

Please take the following measures to protect the PV system from damage of lightning impulse or surge voltage:

- All metal parts (such as framework, support, etc) of PV system must be connected to the main equipotential bus to ensure reliable equipotential connection of the whole system.
- Must keep a safe distance (S) between all parts of PV systems and the external lightning protection system. The external lightning protection system can be connected to the main equipotential bus, fundamental earth screen or ground ring only.
- Adoption of twisted-pair wiring to reduce system jamming.
- For cables from outdoors, the surge protection device should be installed at the entrance of buildings. An all-round and systematic lightning protection should also protect other facilities on buildings from being damaged.

Reasonable wiring:

adoption of twisted-pair wiring with lines as short as possible, to avoid big loop and reduce induced voltage on circuits.

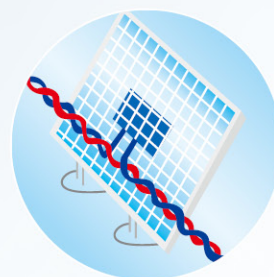

Surge protection device installed on the DC side:

for cables from outdoors, the surge protection device should be installed at the entrance of buildings.

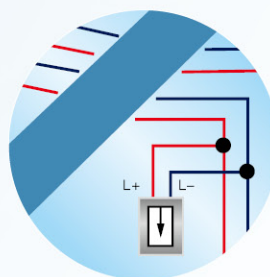



SUP2H-PV Series Surge Protector

SUP2H-PV surge protective device, protect against lightning surge voltages in solar system (photovoltaic power supply system).

These units must be installed in parallel on the DC networks to be protected and provide common and different modes protection. Its installed location are recommended at both ends of the DC power supply line (solar panel side and inverter/converter side), ely if the line routing is external and long.

High energy MOVs equipped with specific thermal disconnectors and related failure indicators.



Specifications

SUP2H-PV series surge protector		SUP2H-PV	
PV DC-specific (LEC 66143-1/EN 61643-31)			
Pole		2P	2P
Electrical Parameter			
Classified test		II	II
UCPV(V DC)		500	800
In(8/20)us (kA)		20	20
Imax(8/20)us (kA)		40	40
Up (kV)		2.8	3.0
Remote control and indication			
Indication window			
Plug-in Module			
Remote signal contact			
Remote signal contact	maximum working voltage(V)	250 AC/30V DC	250AC/30V DC
	maximum working current (A) 1A(250V/ AC)	1A(250V/ AC)	1A(250V/ AC)
	1A (30V DC)	1A(30V/ AC)	1A(30V/ AC)
Wiring & installation			
Wiring capacity(mm ²)	Hard wire	4~25	4~25
	Flexible wire	4~16	4~16
Stripping length(mm)		10	10
Terminal screw		M5	M5
Torque(Nm)	Main circuit	3.5	3.5
	Remote signal contact	0.25	0.25
Protection class	All profile	IP40	IP40
	Connection port	IP20	IP20
Installation environment		No obvious shock and vibration	
Altitude (m)		≤2000	≤2000
Working Temperature		-3.0~+70	-3.0~+70
Relative humidity		30%~90%	30%~90%
How to Install		Installed with H35-7.5/DIN35 steel mounting rail	
Size(mm)(WxHxL)	W	36	54
	H	90	90
	L	67.6	67.6
Weight (kg)		0.24	0.36

SUP2H1-PV Photovoltaic Surge Protective Device



The Cooper suntree three-module photovoltaic Surge Protective Device (SPD) (with three-step DC switching device) features visual indication and optional remote contact signaling (floating changeover contact) for use in PV systems.

These complete surge protective devices are suitable for all PV systems in accordance with IEC 61643-31. Includes a five year limited warranty.

These prewired solutions consist of a base and locking modules that feature a combined disconnection and short-circuiting (shunting) device with safe electrical isolation to prevent fire damage due to DC arcs. An integrated DC fuse allows safe module replacement without arc formation.

In case of insulation faults in the generator circuit, a reliable and tested fault-resistant Y circuit prevents damage to the surge protective devices.

The green and red visual indicator flags show the module protective status (green = good, red = replace). Apart from this visual indication, the remote signaling option features a three terminal floating changeover contact that can be used as a make or break contact depending on the particular monitoring system design employed.

Visual Status Indication 

Remote Signal Contact Available 



CE  ROHS

Dimensions(mm)

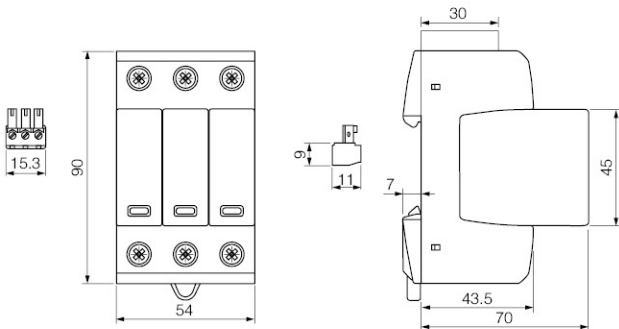

Module Circuit Diagrams

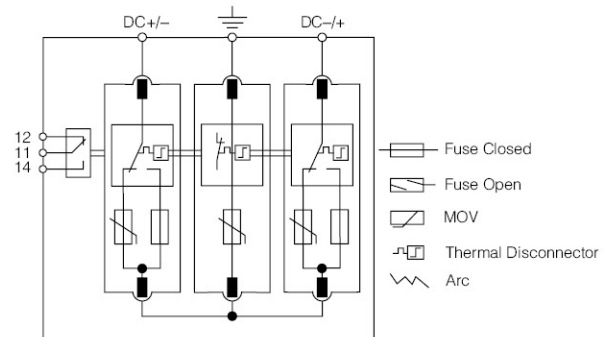

Short-Circuit Interrupting (SCI) Technology

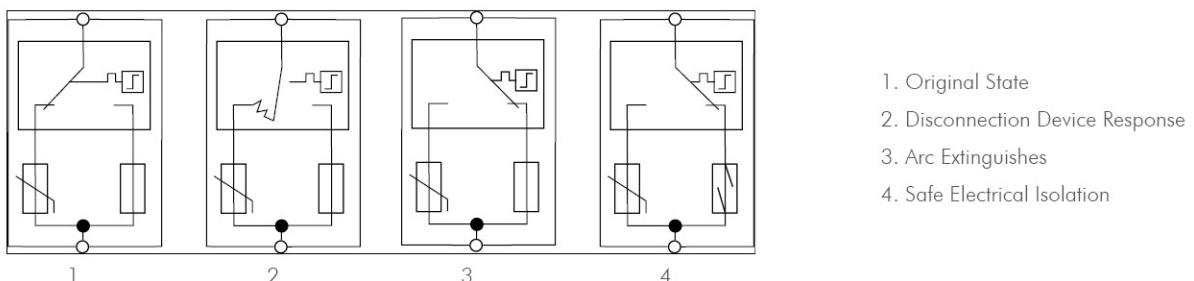

Specifications

SUP2H-PV series surge protector		SUP2H1-PV	SUP2H1-PV	SUP2-PV
UCPV(V DC)		1000V	1200V	1500V
Max System Discharge Current (8/20 μs) [Imax]		40kA	40kA	40kA
Voltage Protection Level [UP]		≤4.0kV	≤4.5kV	≤4.5kV
Voltage Protection Level at 5kA [UP]		≤3.6kV	≤4.0kV	≤5.0kV
Integrated Fuse Breaking Capacity/Interrupting Rating		40kA/1000Vdc	40kA/1200Vdc	40kA/1500Vdc
Technology		Short-Circuit Interruption (SCI) Overcurrent Protection		
Operating Temperature Range [TU]		-40°C to +80°C		
Nominal Discharge Current (8/20 μs) [(DC+/DC-) --> PE] [In]		20kA		
Response Time [tA]		<25ns		
Operating State/Fault Indication		Green (good)/Red (replace)		
Conductor Ratings and Cross-Sectional Area:	Minimum	60/75°C 1.5mm ² /14AWG Solid/Flexible		
	Maximum	60/75°C 35mm ² /2AWG Stranded/25mm ² /4AWG Flexible		
Mounting		35mm DIN Rail per EN 60715		
Enclosure Material		UL 94V0 Thermoplastic		
Degree of Protection		IP20		
Capacity		3 Modules, DIN 43880		
Standards Information:		IEC 61643-31 Type 2, IEC 61643-1 Class II		
Product Warranty		Five Years**		

Remote Contact Signaling

Remote Contact Signaling Type	Changeover Contact
AC Switching Capacity (Volts/Amps)	250V/0.1A
DC Switching Capacity (Volts/Amps)	250V/0.1A; 125V/0.2A; 75V/0.5A
Conductor Ratings and Cross-Sectional Area for Remote	60/75°C Max. 1.5mm ² /14AWG Solid/Flexible
Contact Signal Terminals	
Ordering Information	Order from Catalog Numbers Above

Typical Application Schematics

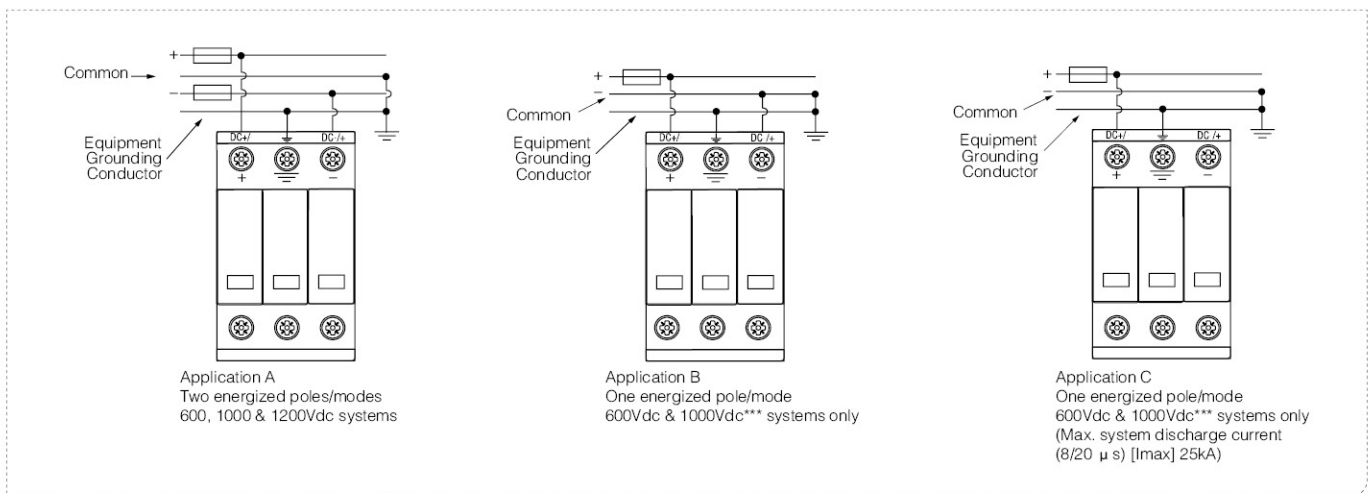

* Does not apply to 1200Vdc.

1. Use a suitable electrical insulator to keep a 10mm min. safety distance from the PV-SPD and other grounded parts in the housing.
2. No metal covers are in the area of the module release buttons as shown.

Conductors and Busbars for Use in Photovoltaic Systems

IEC 60364-7-712 (DIN VDE 0100 Part 712)

60/75°C Cu Conductors		
Min. □DC±, DC±, ↓	1.5mm ² /14AWG	
Max. □DC±, DC±, ↓	25mm ² /4AWG	35mm ² /2AWG
Busbar	16mm ² Cu ≥ 15.5mm	

Visual Indication Status

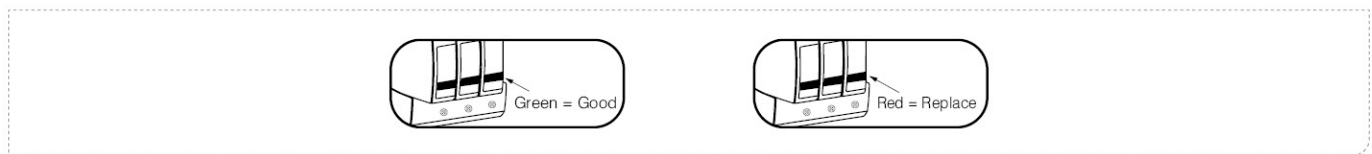

Fault Indication & Remote Contact Signaling (with modules installed)

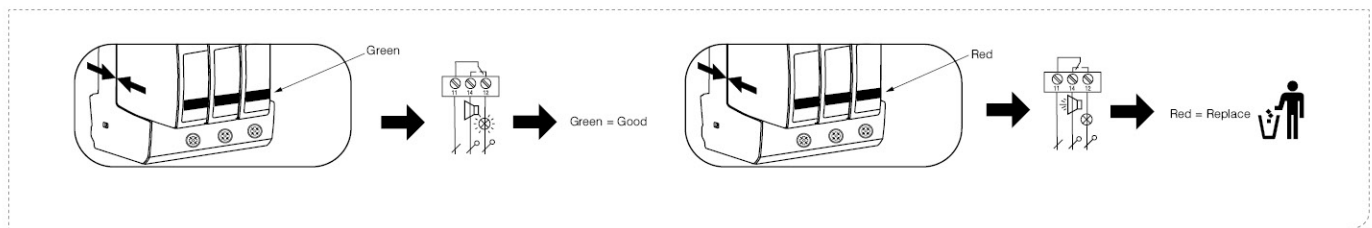

Testing Remote Contact Signaling (with modules removed)

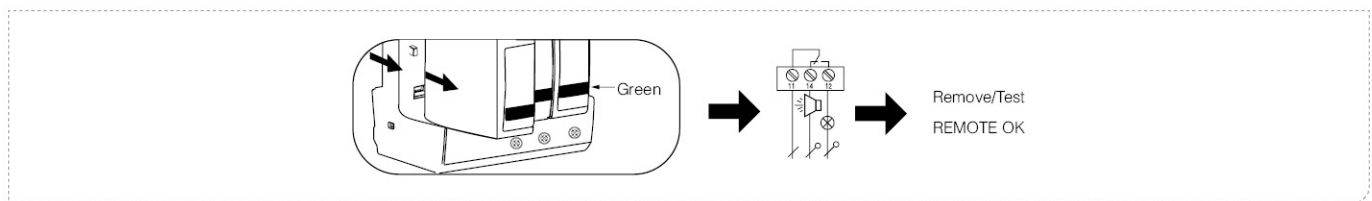

Remote Contact Signaling

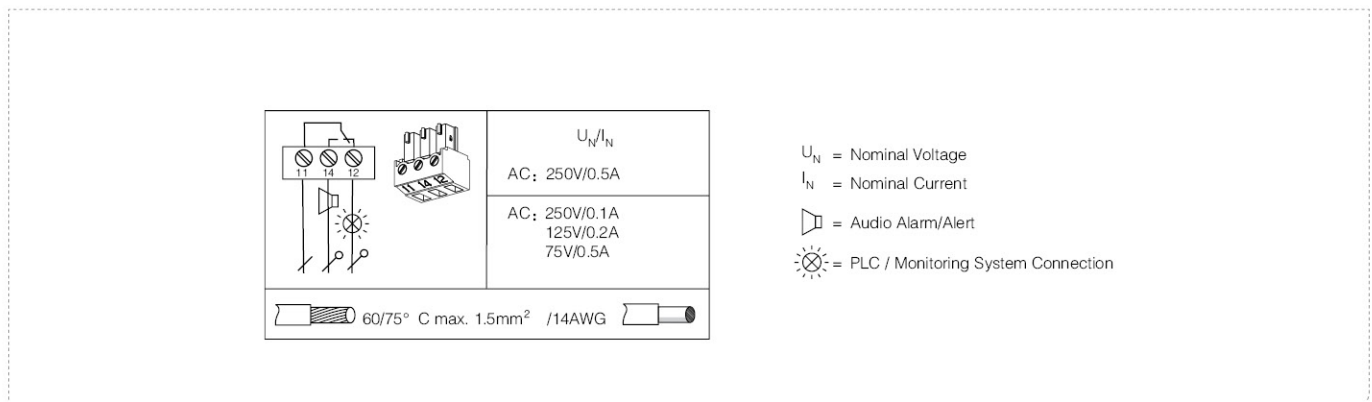

SCB56 SERIES IP66 WATERPROOF BOX

Working status indicator optional



IP66 Distribution Enclosures



IP66 UV stabilised 4 way and 8 way weatherproof enclosures are a vitally important part of any solar installation, if you are using a DC circuit breaker as isolation. For this reason we have worked hard to produce a very high quality IP66 4 way and 8 way enclosure. This enclosure meets all the required standards and has thus been classed as IP66.

This IP66 4 way and 8 way enclosure is designed to house a range of DIN rail circuit breakers and is complete with a storing loaded lockable lid. It also has top, bottom and rear cable entry.

CE ROHS

Specifications

Catalogue Number	Module Type	No. of Poles	No. of Poles
56CB1N	MCB	1	4
56CB2N	MCB	2	4
56CB3N	MCB	3	4
56CB4N	MCB	4	4
56CB5N	MCB	5	8
56CB6N	MCB	6	8
56CB7N	MCB	7	8
56CB8N	MCB	8	8

Dimensions(mm)

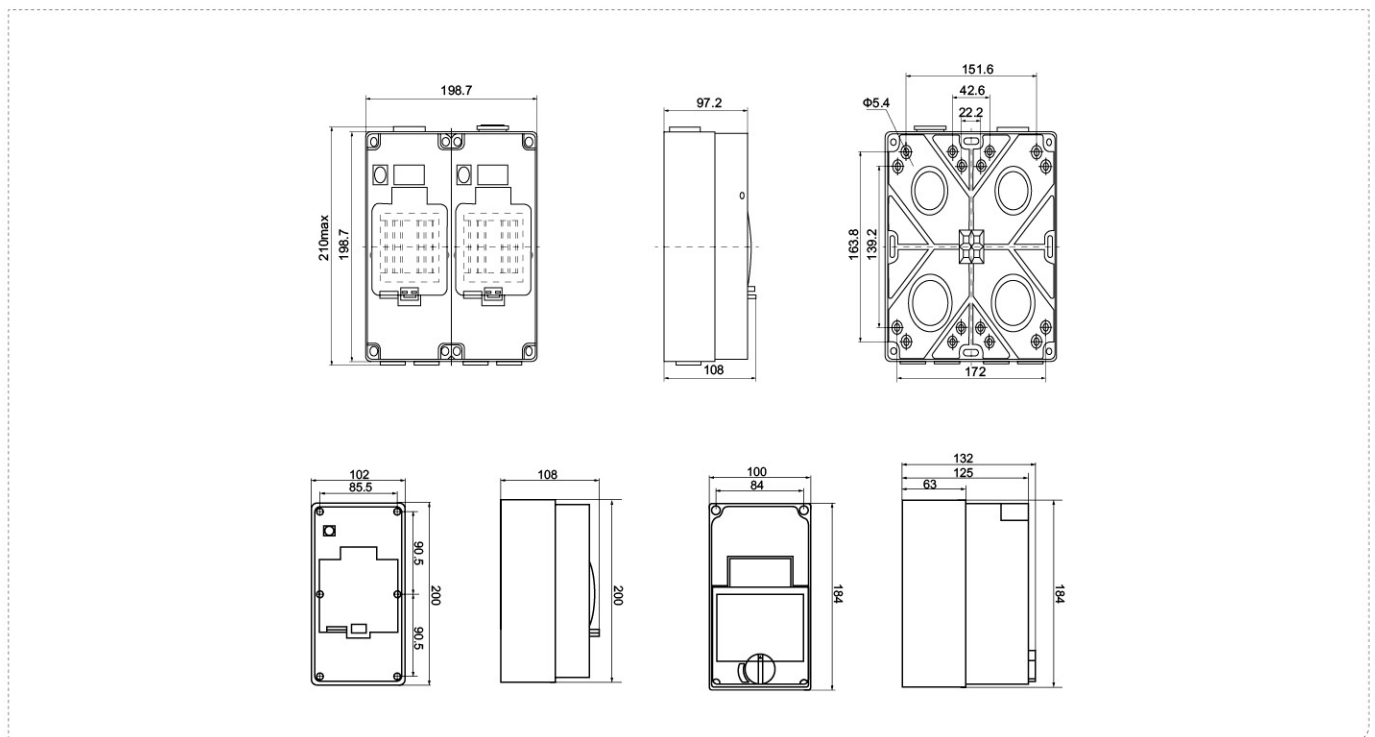

* 8 ways distribution box can be selected from a separate and integral

SMC4 Solar Connector



- Simple on-site processing.
- Accommodates PV cable with different insulation diameters.
- Mating safety provided by keyed housings.
- Multiple plugging and unplugging cycles.
- High current carrying capacity.
- TUV and UL approved.



Specifications

Order NO.	Part P/N		Cable	
	Connector	Terminal	Conductor size (mm ²)	Cable OD (Φ Dmm)
SMC4-CMMM-14	SMC4-CMMM-H	SMC4-CM-T14	AWG 14(2.5 mm ²)	Φ 4.5-Φ 8.5
SMC4-CMMM-12		SMC4-CM-T12	AWG 12(4.0 mm ²)	
SMC4-CMMM-10		SMC4-CM-T10	AWG 10(6.0 mm ²)	
Order NO.	Part P/N	Terminal	Cable	
	Connector	Terminal	Conductor size (mm ²)	Cable OD (mm)
SMC4-CFPM-14	SMC4-CFPM-H	SMC4-CF-T14	AWG 14(2.5 mm ²)	Φ 4.5-Φ 8.5
SMC4-CFPM-12		SMC4-CF-T12	AWG 12(4.0 mm ²)	
SMC4-CFPM-10		SMC4-CF-T10	AWG 10(6.0 mm ²)	
Rated current			30A(2.5-6mm ²)	
Rated voltage			1000v DC	
Test voltage			6000V(50Hz, 1min)	
Overvoltage type/pollution degree			CAT III /2	
Contact resistance of plug connector			1mΩ	
Contact material			Copper, Tin-plated	
Insulation material			PPO	
Degree of protection			IP2X/IP67	
Flame class			UL94-VO	
Safety class			II	
Suitable cable			OD 4.5-8.5(2.5-6.0 mm ²)	
Insertion force/withdrawal force			≤50N/≥50N	
Connecting system			Crimp connection	
Temperature range			-40℃~+125℃	

comparison for internal structure

Connectors of other companies

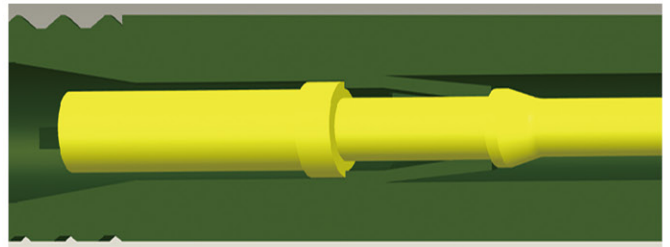
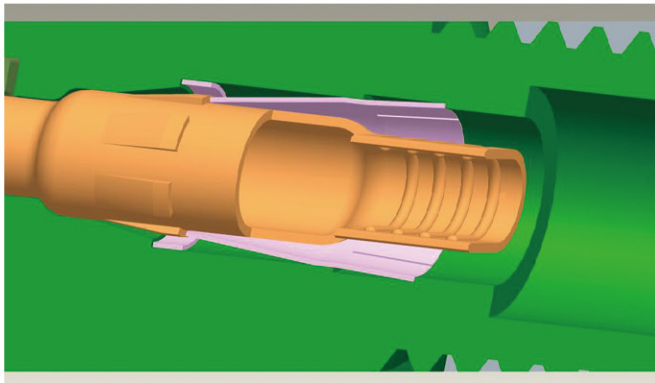

Structure:

Insulator design by forced demoulding Create a slot (red circle marked) to fix spring by forced demoulding. Using spring to position terminal.

Shortcoming:

- Forced demoulding is not very steady It can't ensure any products with same performance.
- Maintain force will change between 7~20kgf.
- Must assemble spring . It is to be a risk that sometimes operator will miss the spring.

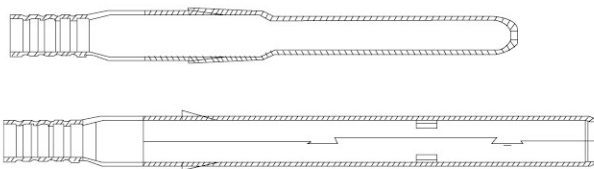

Process: Stamping , Tin plating

Strongpoint:

- Low cost ,high productive capacity.
- It can be continually rivet because of terminal have strip feeder .

Shortcoming

- Material is thin .
- It's easy to deform.
- It will be heat serious in a long time when using
- It need to solder after riveting to reach pull force 31kgf.

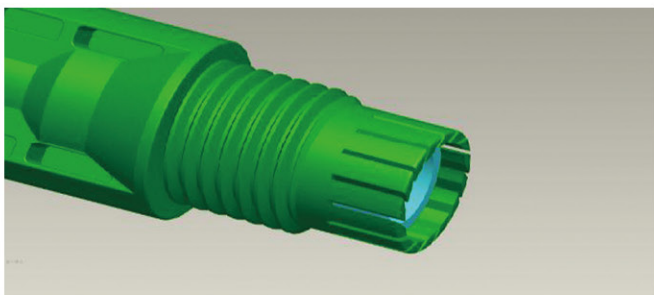

Strongpoint:Simple structure

Shortcoming:

The thread can't return back when screw open
 open
 Because of first reason , it can't be reuse.
 The screw is easy to get open.

Structure:

Moulding a fixed structure to replace spring (red circle marked) .The fixed structure will be expand when terminal insert into insulator . It will be back to original position when terminal is to correct position and hold to terminal.

Shortcoming:

- All product is with same performance.
- Maintain force is 35kgf Min.
- Cut down the accessories.



Process: Lathe Machining , Ag plating

Strongpoint:

- High cost ,low productive capacity
- It can't be continually rivet because it 's without terminal rail.

Shortcoming

- Material is thin .
- It's easy to deform.
- It will be heat slight in a long time when using.
- Pull force can reach 31kgf after riveting.

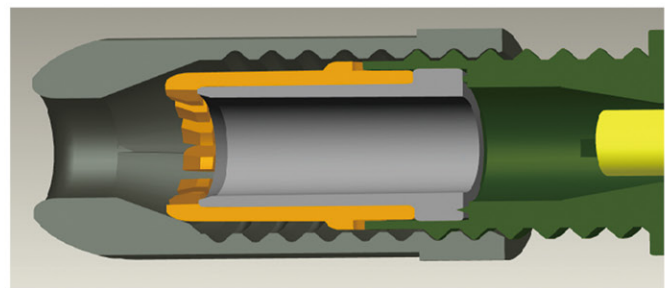

Strongpoint:Add a part

Shortcoming:

The thread can return back when screw open.
 It can be reuse.
 It's with an anti-loosen part ,screw is not easy to get open.



SMC3 Solar Connector

- Simple on-site processing.
- Accomodate PV cable with different insulation diameters.
- Mating safety provided by keyed housings.
- Multiple plugging and unplugging cycles .
- High current carrying capacity.
- TUV and UL approved.



Specifications

Order No.	Part P/N		Cable	
	Connector	Terminal	Conductor size (mm ²)	Cable OD (Φ Dmm)
SMC3-CMMM-14	SMC3-CMMM-H	SMC3-CM-T14	AWG 14(2.5 mm ²)	Φ 4.5- Φ 6.5
SMC3-CMMM-12		SMC3-CM-T12	AWG 12(4.0 mm ²)	
SMC3-CMMM-10		SMC3-CM-T10	AWG 10(6.0 mm ²)	
Order NO.	Part P/N	Cable		
	Connector	Terminal	Conductor size (mm ²)	Cable OD (mm)
SMC3-CFPM-14	SMC3-CFPM-H	SMC3-CF-T14	AWG 14(2.5 mm ²)	Φ 4.5- Φ 6.5
SMC3-CFPM-12		SMC3-CF-T12	AWG 12(4.0 mm ²)	
SMC3-CFPM-10		SMC3-CF-T10	AWG 10(6.0 mm ²)	
Rated current		30A(2-6mm ²)		
Rated voltage		1000V DC		
Test voltage		6000V(50Hz,1min)		
Overvoltage type/pollution degree		CAT III /2		
Contact resistant of plug connector		1mΩ		
Contact material		Copper, Tin-plated		
Insulation material		PPO		
Degree of protection		IP2X/IP67		
Flame class		UL94-VO		
Safety class		II		
Suitable cable		OD 4.5-6.5(2.5-6.0 mm ²)		
Insertion force/withdrawal force		≤50N/≥50N		
Connecting system		Crimp connection		
Temperature range		-40℃~+90℃		

Twins core PV Cable



- Dual wall Insulation, electron beam cross-linked
- Excellent resistance to UV, water, ozone, fluids, salt, general weathering
- Excellent resistance to abrasion
- Halogen free, flame retardant, low toxicity
- Excellent flexibility and stripping performance
- High current carrying capacity
- TUV and UL approved

CE  ROHS

Specifications

Type	Cross section	Strand design	Conductor diameter	Conductor resistance	Outer diameter A×B	Rated voltage	Rated current
	mm ²	No. × Φ (mm)	mm	Ω/km	mm	V AC/DC	A
PV-2x1.5 mm ²	1.5	30 × Φ 0.25	1.6	13.9	5.80 × 9.30	1000/1800	20
PV-2x2.5 mm ²	2.5	50 × Φ 0.25	2.0	8.06	6.20 × 9.90	1000/1800	30
PV-2x4.0 mm ²	4.0	56 × Φ 0.3	2.6	4.97	6.9 × 11.30	1000/1800	50
Wire				Class 5, tinned			
Insulation material				XLPE			
Double insulated							
Halogen-free							
High resistance against oils, greases, oxygen and ozone							
Microbe-resistant							
UV resistant							
High wear and abrasion resistance							
Flam test according to				DIN EN 50265-2-1 UL1571(VW-1)			
Smallest permissible bending radius				5XD			
Temperature range				-40°C ~ +90°C			
Colours				Black/red			

Dimensions(mm)

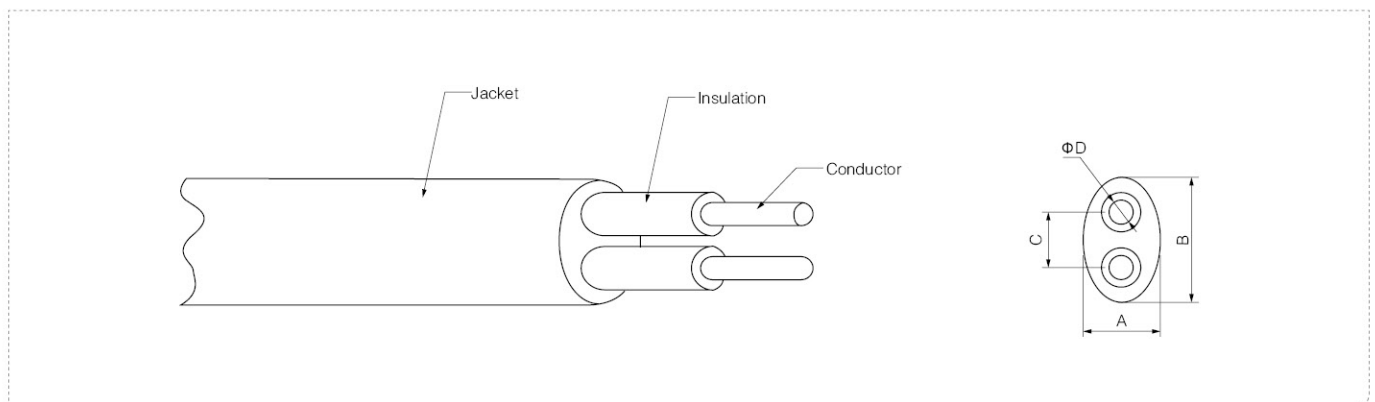



Single core PV Cable

- Dual wall Insulation, electron beam cross-linked
- Excellent resistance to UV, water, ozone, fluids, salt, general weathering
- Excellent resistance to abrasion
- Halogen free, flame retardant, low toxicity
- Excellent flexibility and stripping performance
- High current carrying capacity
- TUV and UL approved

CE  ROHS

Specifications

Type	Cross section	Strand design	Conductor diameter	Conductor resistance	Outer diameter AxB	Rated voltage	Rated current
	mm ²	No. × Φ (mm)	mm	Ω/km	mm	V AC/DC	A
PV-1x1.5 mm ²	1.5	30×Φ0.25	1.6	13.9	4.5	1000/1800	20
PV-1x2.5 mm ²	2.5	50×Φ0.25	2.0	8.06	5.3	1000/1800	30
PV-1x4.0 mm ²	4.0	56×Φ0.3	2.6	4.97	6.4	1000/1800	50
PV-1x6.0 mm ²	6.0	84×Φ0.3	3.3	3.52	7.2	1000/1800	70
PV-1x10.0 mm ²	10.0	200×Φ0.25	4.4	2.12	8.3	1000/1800	95
PV-1x16.0 mm ²	16.0	224×Φ0.3	5.2	1.95	9.5	1000/1800	140
Wire	Class 5, tinned						
Insulation material	XLPE						
Double insulated							
Halogen-free							
High resistance against oils, greases, oxygen and ozone							
Microbe-resistant							
UV resistant							
High wear and abrasion resistance							
Flam test according to	DIN EN 50265-2-1 UL1571 (VW-1)						
Smallest permissible bending radius	5XD						
Temperature range	-40°C ~ +90°C						
Colours	Black/red						

Dimensions(mm)

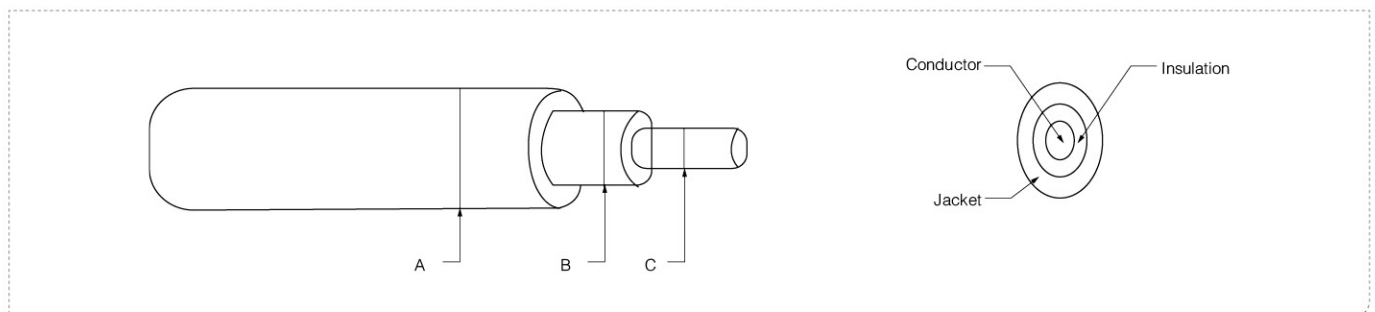

SMC3Y/SMC4Y Solar Connector

- PV Branch
- Plug SMC3Y/SMC4Y-2M1F
- Socket SMC3Y/SMC4Y-2F1M

Specifications

Type And meaning:	
Rated current	30A
Rated voltage	1000V DC
Test voltage	6000V(50Hz,1min)
Overvoltage Category/pollution degree	CAT III /2
Contact resistance of plug connector	1mΩ
Contact material	Copper,Tin-plated
Insulation material	PA/PRO
Degree of protection	IP2*/IP65
Flame class	UL94-VO
Safety class	II
Insertion force	≤50N
withdrawal force	≥50N
Temperature range	-40°C~+110°C



CE ROHS

PV Cable Assembly

Examples of cable assemblies

- Can be customized according to customer requirements

SMC3 TO SMC4



Panel Connector Series



Cable Clips

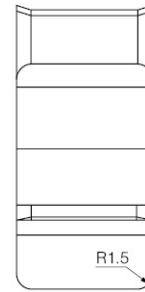
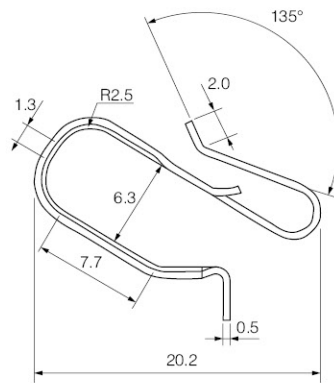
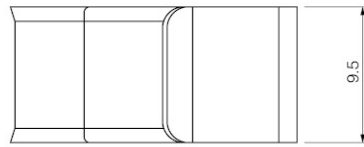

2 × 4mm²

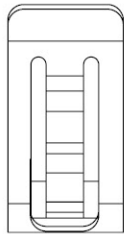
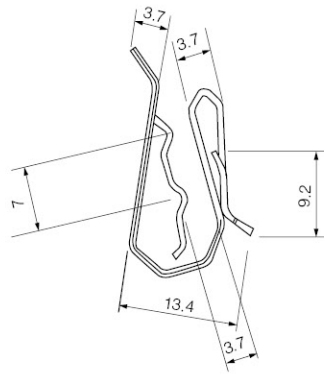
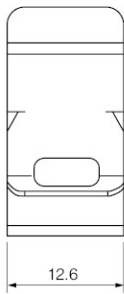

PV DC FUSE

DC Fuse mainly used in DC combiner box in solar PV systems. When PV panel or inverter causes overload or short circuit, it trip off immediately, to protect PV panels. DC fuse also used to protect other electrical parts in DC circuit, when overload or short circuit.

Nylon shell, resistant to high temperatures



Maximum current 400A maximum voltage DC1200V



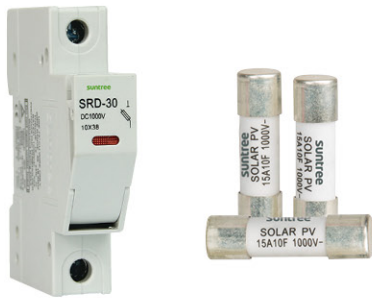

SRD-32gPV 1A-32A Photovoltaic Fuse

Standard: IEC 60269-6, GB/T 13539.6

Interrupting Capacity

30,000 amperes at 1000V DC (Time Constant: 1-3ms)



Specifications

Catalog No.	Current Rating	Safety Approvals
		TUV
32gPV1U0	1A	●
32gPV2U0	2A	●
32gPV3U0	3A	●
32gPV3.5U0	3.5A	●
32gPV4U0	4A	●
32gPV5U0	5A	●
32gPV6U0	6A	●
32gPV8U0	8A	●
32gPV10U0	10A	●
32gPV12U0	12A	●
32gPV15U0	15A	●
32gPV16U0	16A	●
32gPV20U0	20A	●
32gPV25U0	25A	●
32gPV30U0	30A	●
32gPV32U0	32A	●

U0 Denotes For 1000V DC:
 ● Denotes For Approval ○ Denotes For Pending

Electrical Characteristics

% of Current Rating	Blowing Time
113%	1 hour Min.
145%	1 hour Max.

Dimensions

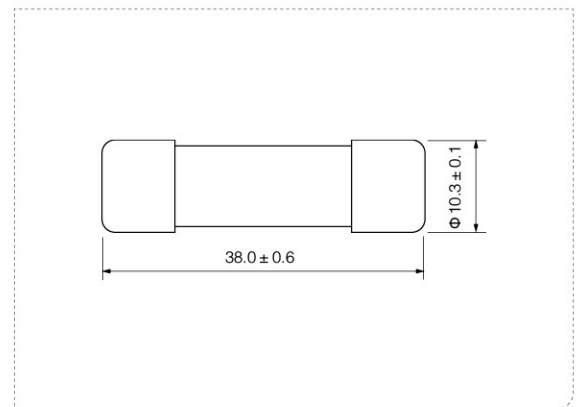

SRD-32gPV

Average I-T Characteristics Curve
(For Reference Only)

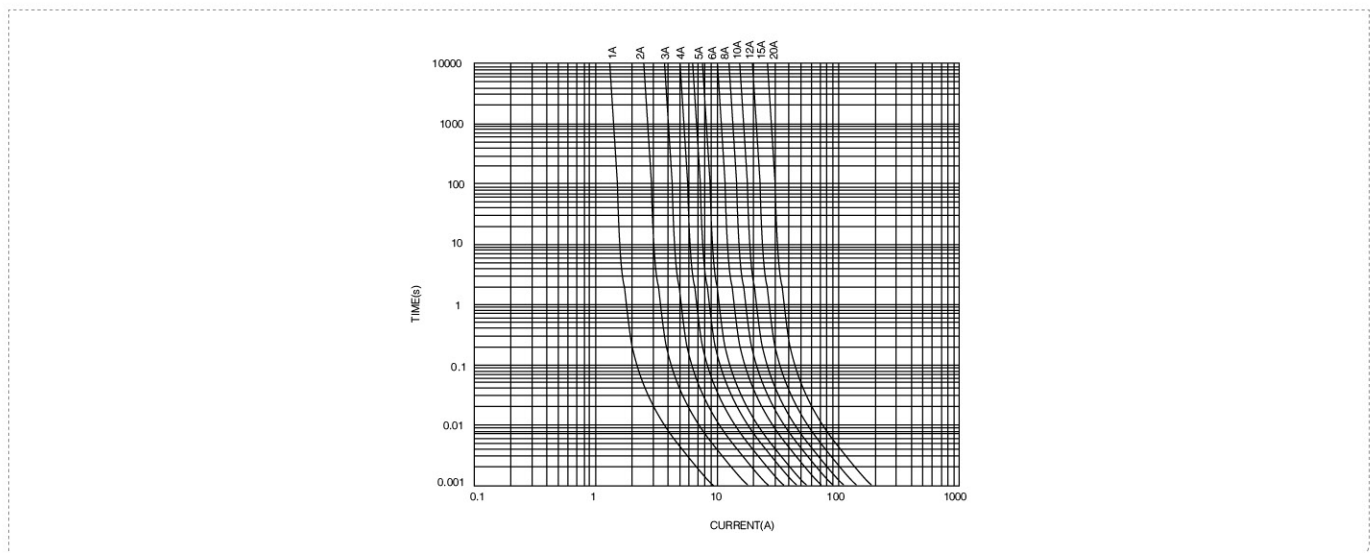

SNH1gPV 1000V DC 32A-160A Photovoltaic Fuse



Standard: IEC 60269-6, GB/T 13539.6

Interrupting Capacity

50,000 amperes at 1000V DC (Time Constant: 1-3 ms)

SNH1B

Recommended fuse-base for NH1 fuse

See Model of product: NH1B



Specifications

Catalog No.	Current Rating	Safety APprovals
		TUV
SNH1gPV32U0	32A	○
SNH1gPV40U0	40A	○
SNH1gPV50U0	50A	○
SNH1gPV63U0	63A	○
SNH1gPV80U0	80A	○
SNH1gPV100U0	100A	○
SNH1gPV125U0	125A	○
SNH1gPV160U0	160A	○

U0 Denotes For 1000V DC
 ● Denotes For Approval ○ Denotes For Pending

SNH1gPV

Average I-T Characteristics Curve (For Reference Only)

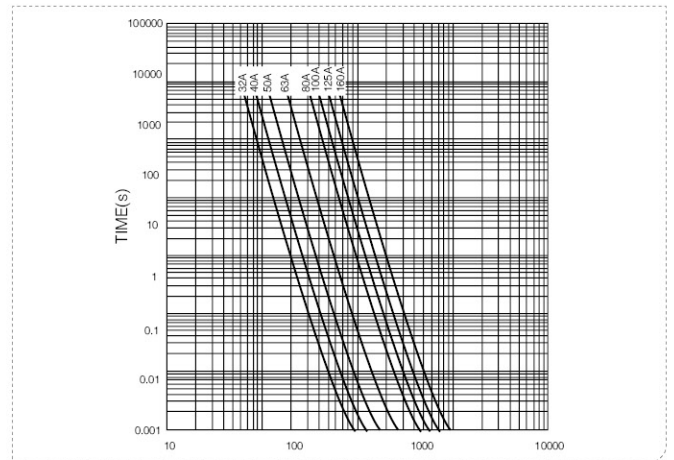

Electrical Characteristics

Rating	Blowing Time	
	1.13In	1.45In
In ≤ 60	1 hour Min.	1 hour Max.
63 < In ≤ 160	2 hour Min.	2 hour Max.

Dimensions(mm)

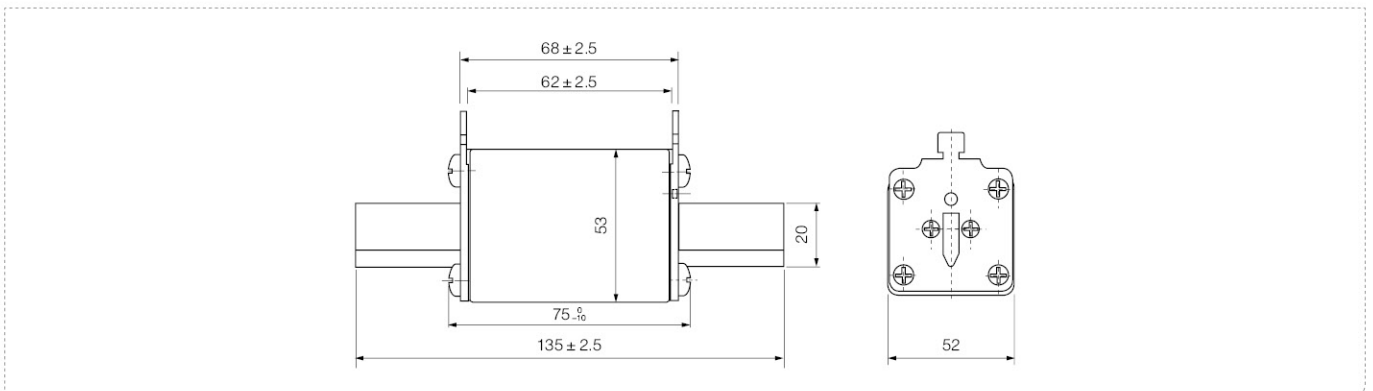

SNH2XLg PV 1100V DC 125A-400A Photovoltaic Fuse

Standard: IEC 60269-6, GB/T 13539.6

Interrupting Capacity

30,000 Amperes At 1100V DC (Time Constant: 1-3ms)



CE  ROHS

Specifications

Catalog No.	Current Rating	Safety Approvals	
		CGC	TUV
2XLgPV125U11A/B	125A	●	●
2XLgPV160U11A/B	160A	●	●
2XLgPV200U11A/B	200A	●	●
2XLgPV250U11A/B	250A	●	●
2XLgPV315U11A/B	315A	●	●
2XLgPV350U11A/B	350A	●	●
2XLgPV400U11A/B	400A	●	●

U11 Denotes For 1100V
 ● Denotes For Approval ○ Denotes For Pending

Electrical Characteristics

Rating	Conventional TIME(H)	Conventional Current	
		Conventional Non-Fusing Current(A)	Conventional Fusing Current(A)
$I_n \leq 60$	2	1.13I _n	1.45I _n
$160 < I_n \leq 400$	3		

SNH2XLB

Recommended fuse-base for NH2XL fuse

See Model of product: NH2XLB NH3LB

CE  ROHS

Dimensions(mm)

Part No.:SNH2XLgPV (amp rating) U11A

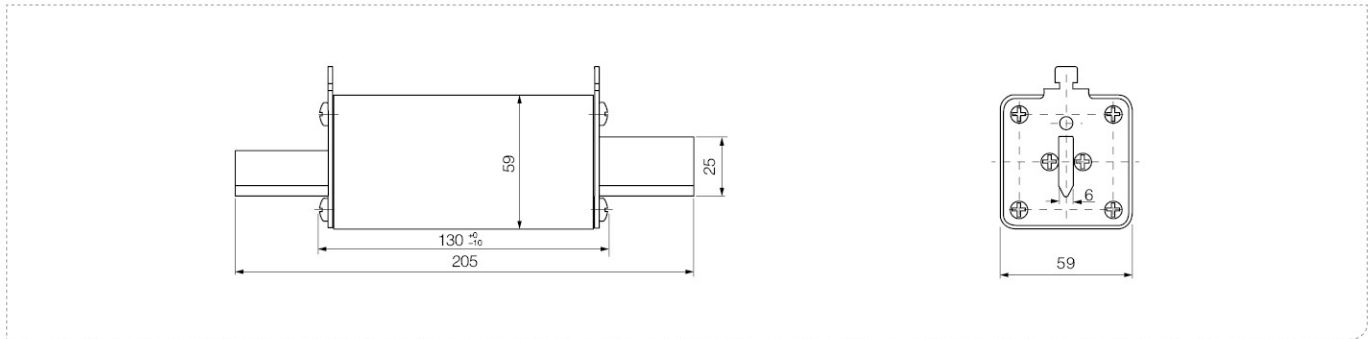

Part No.:SNH2XLgPV (amp rating) U11B

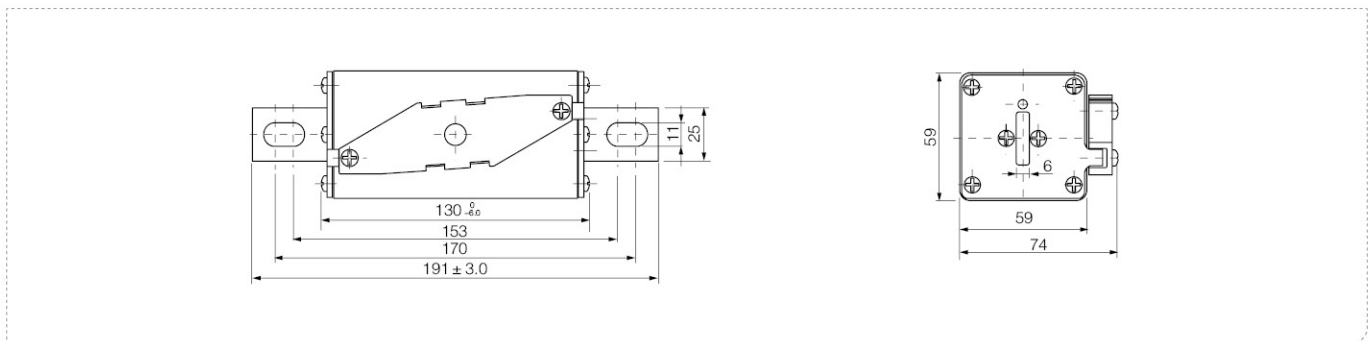

SNH2XLg PV 1100V

Average I-T Characteristics Curve(For Reference Only)

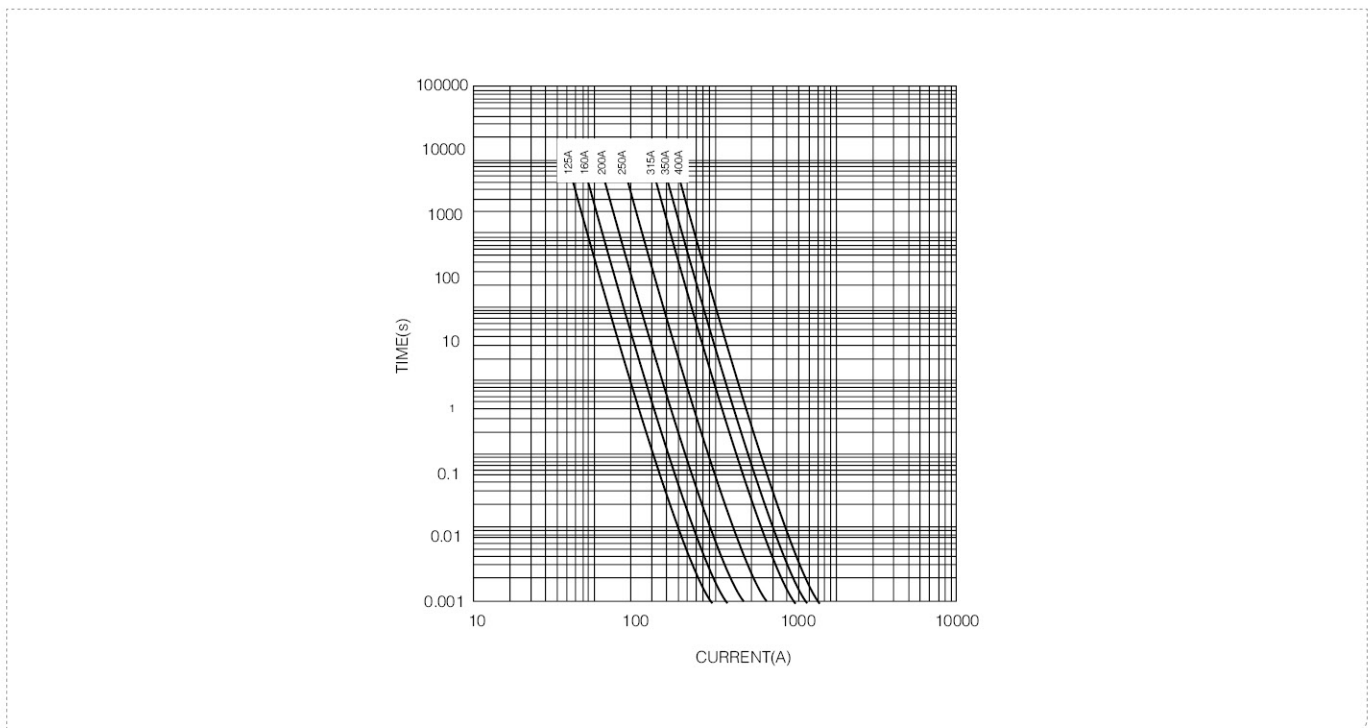

Fuse-base with Blade Contacts



SNH00B



SNH1/2/3B



SNH1/2XLB, NH3LB

Specifications

Model of product	Applicable fuse link size	Rated voltage	Rated current	Safety Approvals
SNH00B	SNH000/NH00	690	160	CCC
		1000	160	

Model of product	Applicable fuse link size	Rated voltage	Rated current	Safety Approvals
SNH1B	SNH01	690	250	CCC
		1000	250	
SNH2B	SNH02	690	400	
SNH3B	SNH03	690	630	

Model of product	Applicable fuse link size	Rated voltage	Rated current	Safety Approvals
SNH1XLB	SNH1XL	1000	250	
SNH2XLB	SNH2XL	1000	400	
SNH3LB	SNH2XL/NH3L	1000	400	TUV
SNH3LB	SNH2XL/NH3L	1000	630	

Dimensions(mm)

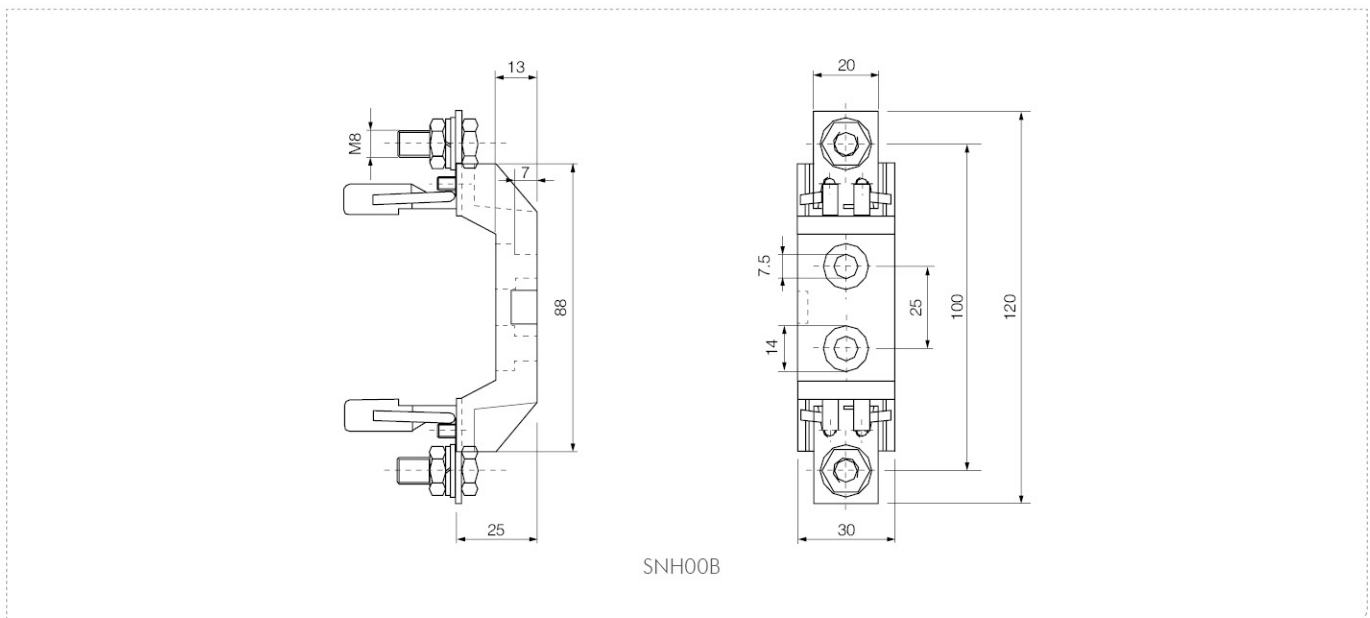

Dimensions(mm)

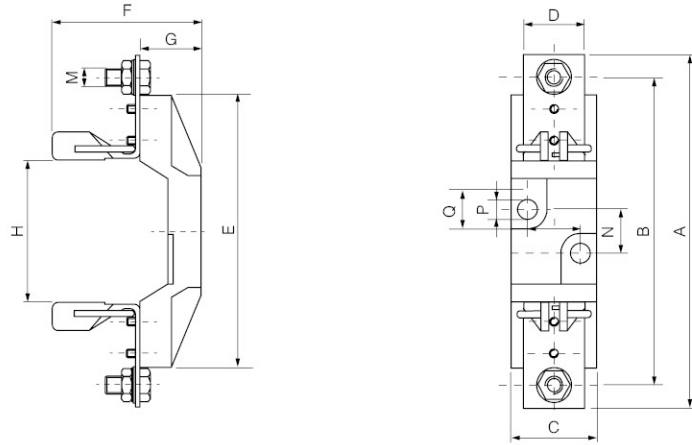

SNH1/2/3B

Size	A	B	C	D	E	F	G	H	I	M	N	P	Q
SNH1	200	175	60	35	155	85	35	80	30	M10	25	10.5	20.5
SNH2	225	200	60	35	155	90	35	80	30	M10	25	10.5	20.5
SNH3	240	210	60	35	155	100	35	80	30	M10	25	10.5	20.5

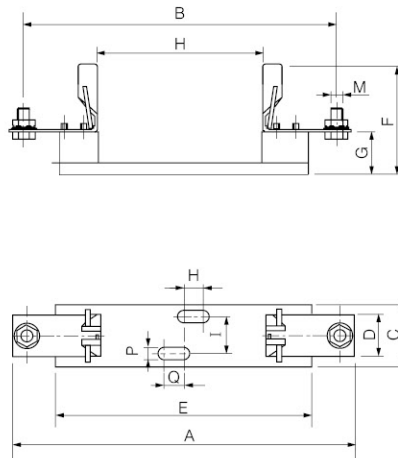

SNH1/2XLB,SNH3LB

Size	A	B	C	D	E	F	G	H	I	M	N	P	Q
SNH1XL	200	175	60	35	155	85	35	80	30	M10	25	10.5	20.5
SNH2XL	225	200	60	35	155	90	35	80	30	M10	25	10.5	20.5
SNH3XL	240	210	60	35	155	100	35	80	30	M10	25	10.5	20.5



Application

This series of fuse is suitable for solar photovoltaic power generation system, rated voltage to 1500V, rated current to 50A, connected with photovoltaic panels and batteries, to charge variable flow system for short circuit breaking protection in photovoltaic station and photovoltaic power generation system. The rated breaking capacity is 20KA, products conform to IEC60269.6

Normal Working Conditions

Ambient Temperature: -40°C – + 90°C

Equipment installation height: less than 2000m

(if you want use exceeding this height, pls tell us in advance, we can design according to your requirements)

Use Category

gPV means all range DC Fuse used for breaking protection in solar photovoltaic power generation system

Structure

Fuse Link is made of pure silver, welding low tin and encapsulated in the high-strength porcelain, the fuse tube filled with high pure quartz sand with chemically processed as a arc medium, fuse body is connected with contacting terminals by spot welding.

Main Technical Specification

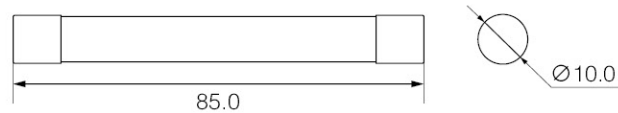

Model	Rated Voltage (V)	Rated Current (A)	SIZE(mm)
SRF-30	DC1500V	2-30	See Above Drawing

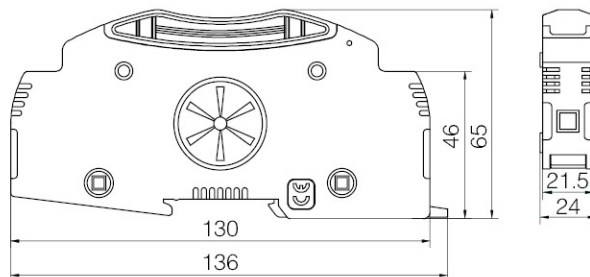

Model	Fuse Size	Rated Voltage (V)	Rated Current (A)	SIZE(mm)
SRD-30	10/14×85	DC1500V	2-50A	See Above Drawing

Testing Method

Appointed time and current

gPV Fuse current rated (A)	Appointed Timeh	Appointed Current	
		Inf	If
$I_n \leq 63$	1	1.13I _n	1.45I _n
$63 < I_n \leq 160$	2		
$160 < I_n \leq 400$	3		
$I_n > 400$	4		

Characteristic Curve

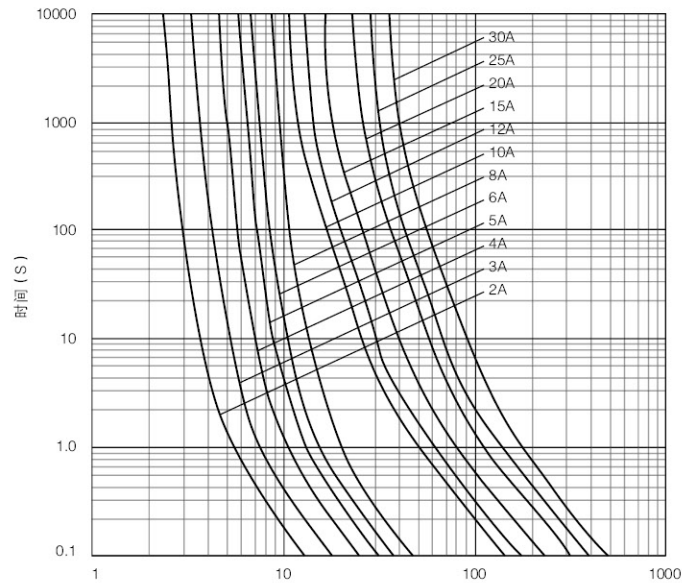

Main Technical Specification

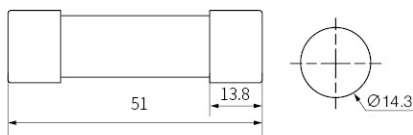

Model	Rated Voltage (V)	Rated Current (A)	SIZE(mm)
SRF-30	DC1500V	10A-32A	See Above Drawing

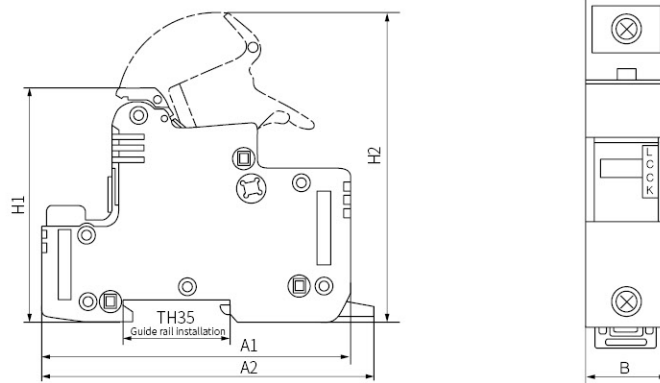

Model	Fuse Size	Rated Voltage (V)	Rated Current (A)	SIZE(mm)				
				A1	A2	B	H1	H2
SRD-32	14x51	DC1500V	10-32A	107	111	27	72	100

Testing Method

Appointed time and current

gPV Fuse current rated (A)	Appointed Timeh	Appointed Current	
		Inf	If
$I_n \leq 63$	1	1.13I _n	1.45I _n
$63 < I_n \leq 160$	2		
$160 < I_n \leq 400$	3		
$I_n > 400$	4		

Characteristic Curve

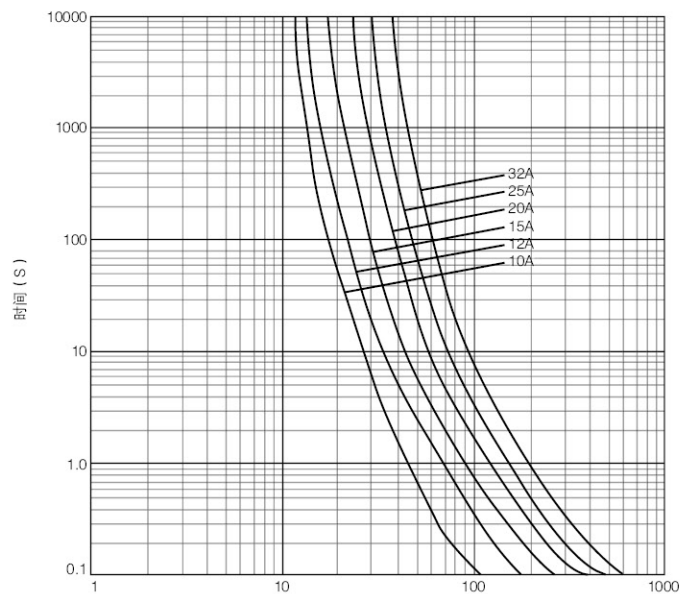



Accept the different needs of customization

PV LIGHTNING PROTECTION CABINET

Various lightning protection cabinets with all kinds of functions launched only by Suntime involve surge protection, over-current protection, connection, switching and many other devices. Design of these lightning protection cabinets are fully in accordance with the standard CLC/TS 50539-12. The products are widely used on AC and DC sides of PV inverters. Custom made according to your requirements is available.



PV lightning protection cabinet

Distributed substation used lightning protection cabinet

Various lightning protection cabinets with all kinds of functions launched only by Suntree involve surge protection, over-current protection, connection, switching and many other devices. Design of these lightning protection cabinets are fully in accordance with the standard CLC/TS 50539-12. The products are widely used on AC and DC sides of PV inverters. Custom made according to your requirements is available.

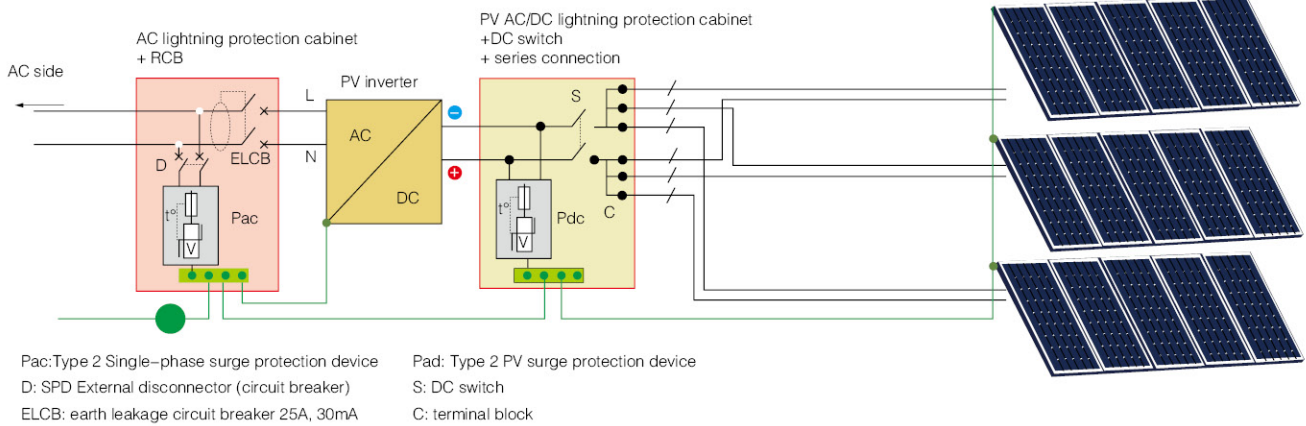

SPV240 Series

AC lightning protection cabinet



Model	SPV240-230-XXX-DDR
Power grid voltage Un	230V single-phase
Max current	16A-25A-32A
Circuit connection (input/output)	6mm ² max

Safety	
Thermal disconnector	Built-in
Visible disconnecting index	Lightning protection indicator
Surge protection	Surge protection device
Over-current protection	Circuit breaker (16 or 32A)
Protect against indirect contact	Differential circuit breaker 30mA
Type2 Surge protection device	SUP2-230/G
Max continuous working voltage Uc	255VAC
Nominal discharge current In	20kA
Max discharge current I _{max}	40kA
Voltage protection level (common mode/differential mode) Up	1,5/1,25kV

Structural parameters	
Shell material	UL90-Vo
Waterproof grade	IP55

Distributed substation used lightning protection cabinet

SPV50-XXX-XXA-XST Series

DC lightning protection cabinet



Model	SPV50-500-40A-3ST	SPV50-600-40A-3ST	SPV50-800-40A-3ST
Array string number	3	3	3
Max PV voltage U_{ocstc}	500VDC	600VDC	800VDC
Max PV current I_{mppstc}	25A	25A	25A
Circuit connection (input/output)	Terminal 6,5/10mm ²	Terminal 6,5/10mm ²	Terminal 6,5/10mm ²
DC switch	Yes	Yes	Yes
Fuse wire protection of branch circuit	Optional	Optional	Optional

Type2 Surge protection device	SUP2-PV500/51	SUP4-PV800/51	SUP4-PV1000/51
Max PV voltage U_{cpv}	600VDC	720VDC	960VDC
Nominal discharge current I_n	15kA	15kA	15kA
Max discharge current I_{max}	40kA	40kA	40kA
Voltage protection level U_p	2,2kV	2,8kV	2/3,6kV

Structural parameters	
Shell material	ABS PC
Ingress protection	IP65

SPV240-50 Series

AC/DC lightning protection cabinet

Model	SPV240-50-230-XX-DDR	
Power grid type	AC single-phase grid	2-string-DC grid
Working voltage U_n/U_{ocstc}	230V single-phase	600VDC
Max current	16A-25A-32A	25A
Connection mode	Max 6mm ² screw terminal connection	Max 6mm ² MC interface connection

Type2 Surge protection device	SUP2-230/G	SUP4-600/51
Max continuous working voltage U_c	255Vac	720Vdc
Nominal discharge current I_n	20kA	15kA
Max discharge current I_{max}	40kA	40kA
Protection level U_p	1,5/1,25kV	2,8kV

Structural parameters	
Shell material	UL90-Vo
Ingress protection	IP55

Automatic Reclosing MCB



SCB8ZY-80 : It combiner mini circuit breaker and mini intelligent electric motor, circuit breaker will be turned on or off when it test the meter' s control signal, used with prepaid meter, then will be turn on after paid, and turn off when Arrears.

SCB8ZY-80: It combiner mini circuit breaker and mini intelligent electric motor, with function of over voltage, under voltage, lose voltage, delay, automatic turn on when return to normal voltage.



Over Load Protection Data

Rated Current	Start State	Test Current	Standard time	Result	Mark
10~80A	Cold state	1.13 In	$t \leq 1h(\leq 63A)$ $t \leq 2h(80A)$	NO Trip	Current will up to standard current within 5s
10~80A	After finishe the 1.13 In test	1.45In	$t < 1h(\leq 63A)$ $t < 2h(\leq 80A)$	Trip	
$I_n \leq 32A$	Cold state	2.55In	$1s < t < 60s$	Trip	
$I_n > 32A$	$I_n \leq 32A$	Cold state	$1s < t < 120s$	Trip	Type C
10~80A	-	5In	$t \leq 0.1s$	NO Trip	
-	-	10In	$t < 0.1s$	Trip	
-	-	10In	$t \leq 0.1s$	NO Trip	
-	-	14In	$t < 0.1s$	Trip	Type D
Frame Current	80				
Rated insulation voltage	500V				
Rated Frequency	50HZ/60HZ				
Rated impulse withstand voltage	4KV				
Poles	1P+N, 3P+N				
Trip type	C, D				
Rated short circuit Capacity Ics	6KA(80A), 10KA(10-63A)				

Technology Data

Working short circuit Capacity Ics	6KA(80A), 7.5KA(10-63A)
Mechanical life	20000
Electric lifi	8000
Working range	(65%-120%)Un
Control signal voltage	AC220V 50HA
Turn on delay time	$t \geq 4s$
Reclosing delay time	$t \leq 3s$
Working Temperature	-25°C~+60°C
Relative humidity	Less than 95% (+20°C); Less than 50% (+40°C)
Cross sectional area of Signal cable	0.3mm ²
Signal cable length	50mm (accept customize)
Installation method	DIN Rail Mounted

Trip Curve

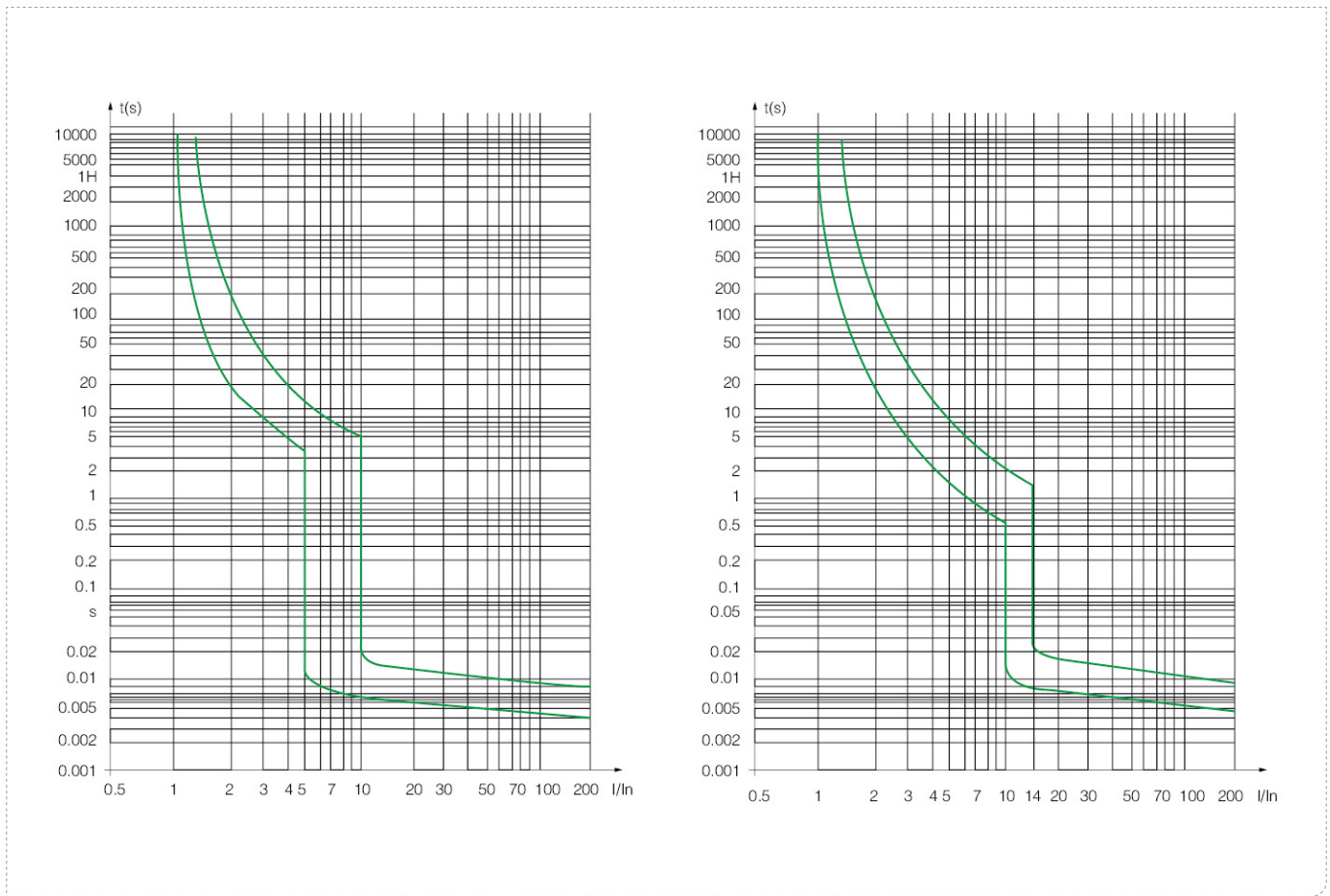

Product Dimention

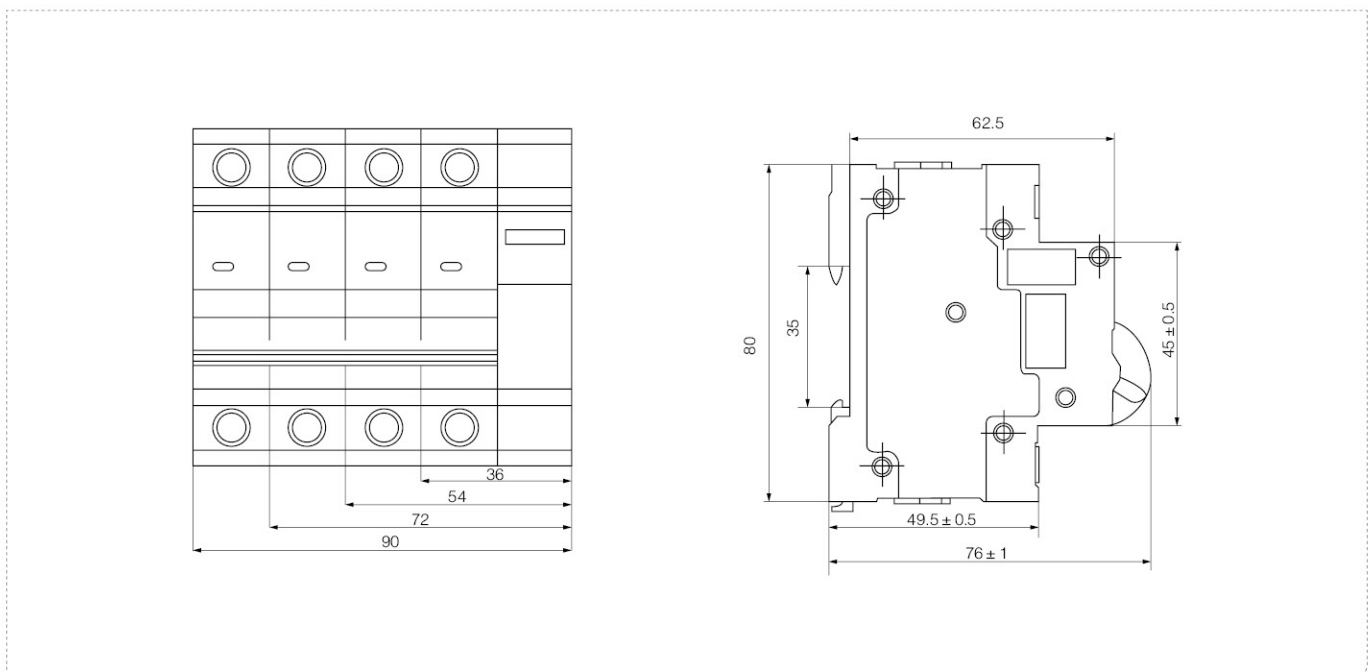

Application

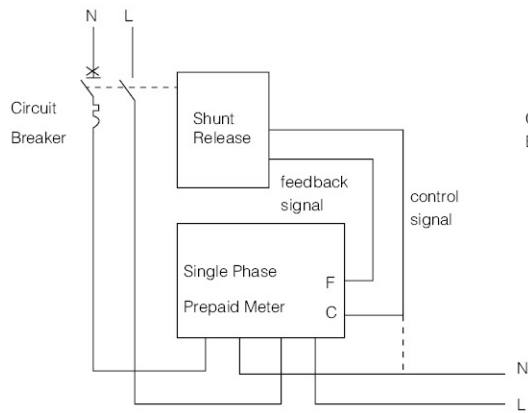

Single phase Wiring Diagram

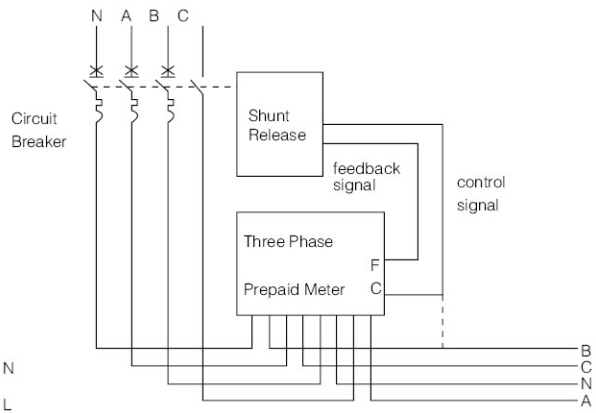

Single phase Wiring Diagram

SCB8ZY-80

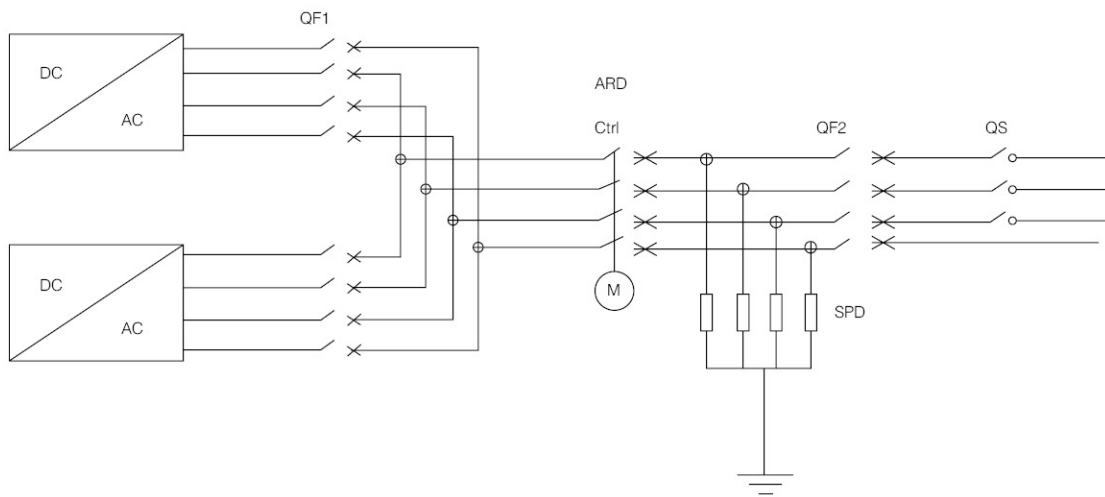

SCB8ZY-80

Solar System Components Layout Reference

Solar System Type	Inverter Type	Inverter QTY	PV Panel Type	PV Panel QTY	DC Isolating Switch Type	DC Switch QTY	DC MCB Type	DC MCB QTY	DC Combiner Box Type	DC Combiner Box QTY	DC SPD Type	DC SPD QTY	MC4 Type	MC4 QTY
2KW-SP-1 MPPT	LS2000H	1	260	8	SISO-25 600VDC 25A	1	SL7-63/2P 25A 800VDC	1	1/1	1	SUP2-PV 20/40 600VDC	1	SMC4-4	4
3KW-SP-1 MPPT	LS3000H	1	260	12	SISO-25 600VDC 25A	1	SL7-63/2P 25A 800VDC	1	1/1	1	SUP2-PV 20/40 600VDC	1	SMC4-4	4
4KW-SP-1 MPPT	LS4000H	1	260	16	SISO-25 600VDC 25A	2	SL7-63/2P 25A 800VDC	2	2/2	1	SUP2-PV 20/40 600VDC	2	SMC4-4	8
5KW-SP-1 MPPT	LS5000H	1	260	20	SISO-25 600VDC 25A	2	SL7-63/2P 25A 800VDC	2	2/2	1	SUP2-PV 20/40 600VDC	2	SMC4-4	8
3KW-SP-2 MPPT	LS3000HD	1	260	12	SISO-25 600VDC 25A	2	SL7-63/2P 25A 800VDC	2	2/2(fitting)	1	SUP2-PV 20/40 600VDC	2	SMC4-4	8
4KW-SP-2 MPPT	LS4000HD	1	260	16	SISO-25 600VDC 25A	2	SL7-63/2P 25A 800VDC	2	2/2(fitting)	1	SUP2-PV 20/40 600VDC	2	SMC4-4	8
5KW-SP-2 MPPT	LS5000HD	1	260	20	SISO-25 600VDC 25A	2	SL7-63/2P 25A 800VDC	2	2/2(fitting)	1	SUP2-PV 20/40 600VDC	2	SMC4-4	8
5KW-TP	LT5000HD	1	260	20	SISO-25 1000VDC 25A	2	SL7-63/4P 25A 1000VDC	2	2/2(fitting)	1	SUP2-PV 20/40 1000VDC	2	SMC4-4	8
6KW-TP	LT6000HD	1	260	24	SISO-32 1000VDC 32A	2	SL7-63/4P 32A 1000VDC	2	2/2(fitting)	1	SUP2-PV 20/40 1000VDC	2	SMC4-4	8
8KW-TP	LT8000HD	1	275	30	SISO-32 1000VDC 32A	2	SL7-63/4P 32A 1000VDC	2	2/2(fitting)	1	SUP2-PV 20/40 1000VDC	2	SMC4-4	8
10KW-TP	LT10000HD	1	260	40	SISO-32 1000VDC 32A	2	SL7-63/4P 32A 1000VDC	2	2/2(fitting)	1	SUP2-PV 20/40 1000VDC	2	SMC4-4	8
15KW-TP	LT15000HD	1	260	58	SISO-32 1000VDC 32A	4	SL7-63/4P 32A 1000VDC	4	4/4(fitting)	1	SUP2-PV 20/40 1000VDC	2	SMC4-4	16
18KW-TP	LT18000HD	1	260	70	SISO-32 1000VDC 32A	4	SL7-63/4P 32A 1000VDC	4	4/4(fitting)	1	SUP2-PV 20/40 1000VDC	2	SMC4-4	16
20KW-TP	LT20000HD	1	260	80	SISO-32 1000VDC 32A	4	SL7-63/4P 32A 1000VDC	4	4/4(fitting)	1	SUP2-PV 20/40 1000VDC	2	SMC4-4	16
30KW-TP	LT30000HD	1	265	114	SISO-32 1000VDC 32A	6	SL7-63/4P 32A 1000VDC	6	6/6(fitting)	1	SUP2-PV 20/40 1000VDC	3	SMC4-4	24
33KW-TP	LT33000HD	1	275	120	SISO-32 1000VDC 32A	6	SL7-63/4P 32A 1000VDC	6	6/6(fitting)	1	SUP2-PV 20/40 1000VDC	3	SMC4-4	24
40KW-TP	LT40000HD	1	275	144	SISO-32 1000VDC 32A	6	SL7-63/4P 32A 1000VDC	6	6/6(fitting)	1	SUP2-PV 20/40 1000VDC	3	SMC4-4	24