

Smartgen®

HGM180/180HC

Automatic Control Module

User Manual



Smartgen Technology

Smartgen®

Smartgen Technology Co., Ltd

No.28 Jinsuo Road

Zhengzhou

Henan Province

P. R. China

Tel: 0086-371-67988888/67981888
0086-371-67991553/67992951/67992952
0086-371-67981000(overseas)

National Free Tel: 4000318139

Fax: 0086-371-67992952/67981000

Web: <http://www.smartgen.com.cn>
<http://www.smartgen.cn>

Email: sales@smartgen.com.cn

All rights reserved. No part of this publication may be reproduced in any material form (including photocopying or storing in any medium by electronic means or other) without the written permission of the copyright holder.

Applications for the copyright holder's written permission to reproduce any part of this publication should be addressed to Smartgen Technology at the address above.

Any reference to trademarked product names used within this publication is owned by their respective companies.

Smartgen Technology reserves the right to change the contents of this document without prior notice.

Software Version

Date	Version	Notes
2007-12-01	1.0	Original release
2010-08-18	2.5	Change over speed time from 3s to 1.5s
2011-06-13	2.6	Change the name of the company "Smartgen electronics" to "Smartgen Technology".
2011-12-22	2.7	Modify Typical Application .

CONTENTS

1 SUMMARY	4
2 PERFORMANCE AND CHARACTERISTICS	4
3 SPECIFICATION.....	4
4 PANEL OPERATION	5
4.1 Keys and Indicators	5
4.2 Stop Position (○)	6
4.3 Manual Position (Ⓜ).....	6
4.4 Auto Position (Auto).....	6
5 ALARM.....	7
6 SETTING.....	7
7 TERMINALS FUNCTION.....	8
8 TYPICAL APPLICATION	9
9 CASE DIMENSIONS (panel cutout 78 mm*66mm).....	9
9.1 Battery Voltage Input.....	9
9.2 Output and Expansion Relay.....	9
9.3 Withstand Voltage Test	10
10 FAULT FINDING	10

1 SUMMARY

HGM180HC auto start module is an engine control module designed to control the engine via pushbuttons on the front panel or remote start signal. The module has 3 working modes to choose. When detecting faults, such as low oil pressure, high water/cylinder temperature, auxiliary alarm, over speed, it will disconnect fuel relay and energize to stop. LED annunciator displays the faults, which can offer real and effective alarm information.

2 PERFORMANCE AND CHARACTERISTICS

- ◆ Wide range of DC power input;
- ◆ With low oil pressure, high water/cylinder temperature, over speed protection and indication;
- ◆ Charge fail warn, not shutdown;
- ◆ With an additional auxiliary input signal, alarm to shutdown;
- ◆ Speed signal is from power frequency;
- ◆ LED displays all kinds of alarm states;
- ◆ With run hour LCD display;
- ◆ With fuel oil output, starting output, preheat output, shutdown output, common alarm/idle output, all relay output;
- ◆ With the idle control function, idle delay time is programmable;
- ◆ Preheat delay time is programmable;
- ◆ Crank disconnect conditions can choose oil pressure + generator (factory default), also can choose only generator;
- ◆ When dial the code switch to idle/high speed active, idle/high speed output can be configured, or it will be common alarm output. See the picture:
- ◆ Modular structure design, ABS plastic casing, embedded installation, compact structure with small volume, advanced SCU control, stable performance and convenient operation.

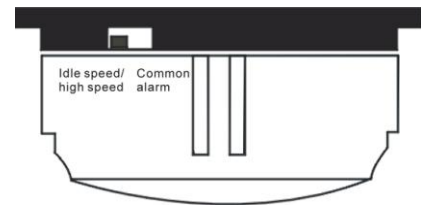

3 SPECIFICATION



Items	Contents
Working Voltage	DC8.0V to 35.0V continuous
Power Consumption	Standby (12V: 0.12W, 24V: 0.24W) Working (12V: 0.5W, 24V: 1W)
Alternator Voltage Input	15VAC - 360VAC (ph-N)
Alternator Rated Freq.	50/60Hz
Over Speed Freq.	114% of rated freq.
Condition of Crank Disconnect	Generator voltage ≥ 15 VAC and frequency ≥ 15 Hz
Charge Failure Voltage	< 3 V
4 Digital Inputs	Connect to B- active
Start Output	1Amp DC28V relay output B+

Items	Contents
Preheat Output	1Amp DC28V relay output B+
Fuel Output	1Amp DC28V relay output B+
Stop Output	1Amp DC28V relay output B+
Programmable Output	1Amp DC28V relay output B+
Hours Counter	Max 99999.9 hours
Case Dimensions	84mm x72mm x 35mm
Panel Cutout	78mm x 66mm
Working Condition	Temperature: (-30~+70)°C Humidity: (20~90)%
Storage Condition	Temperature: (-40~+80)°C
Protection Level	IP55: when waterproof rubber gasket added between controller and its panel. IP42: when waterproof rubber gasket not added between controller and its panel.
Insulation Intensity	Object: among input/output/power Quote standard: IEC688-1992 Test way: AC1.5kV/1m 3mA leakage current
Weight	0.2kg





4 PANEL OPERATION

4.1 Keys and Indicators

➤ keys



	Set	Pressing this key can set parameters.
	Manual	In Manual Mode, press this key to start genset; In Stop Mode or Auto Mode, this key is inactive.
	Preheat	In Manual Mode, press this to output preheat signal; In Stop Mode or Auto Mode, this key is inactive.

➤ Indicators





	High Temperature	When engine stops for high temperature, it illuminates.
	Low Oil Pressure	When engine stops for low oil pressure, it illuminates.
	Over Speed	When engine over speed, it illuminates.
	Charge Failure	When engine failed to charge, it illuminates.
	Common Alarm	When over speed, temperature high, oil pressure low, auxiliary shutdown alarm, fail to start and

		fail to stop alarms occur, it illuminates.
	Hours Counter	Genset accumulated run hours. Max 99999.9 hours.

4.2 Stop Position (○)

- ◆ During genset normal running, turn the key to stop position, enter into idle process and idle/high speed relay disconnect. When idle delay is over, fuel relay disconnects ETS output and genset stops.
- ◆ When a fault alarm occurs, turn the key to stop position, alarm can be removed.
- ◆ When genset at rest, turn key to stop position, controller will be in low power consumption standby mode.
- ◆ In this mode, preheat key  and start key  are inactive.

4.3 Manual Position ()

- ◆ Turn the key to manual position. Press  key, preheat outputs and disconnects before starter is powered. After crank disconnect, preheat output is disable.
- ◆ Turn the key to manual position. Press  key, after preheat outputs 1s, starter is energized to output and genset starts. When gens frequency over 15Hz or OP sensor is disabled (OP sensor is enabled before start) or release start key , starter power off and crank disconnect. After 10s' safety delay, idle delay begins. When idle delay is over, idle/high speed relay closes and genset enters into high speed running.
- ◆ In this mode, long pressing  key is for lamp test.

4.4 Auto Position ()

- ◆ Turn the key to Auto position. When remote start signal is enabled (connect to B-), after 2s delay, genset will start automatically, preheat delay begins. When the delay is over, fuel outputs, preheat output disconnects after 1s, then crank begins. (Maximum 3 times to start, 8s for cranking and 10s interval. If crank disconnect within 3 times, module is started; if fail to disconnect every time, common alarm annunciator illuminates and relay outputs), when gens frequency is over 15Hz or oil pressure sensor is disabled (oil pressure sensor must be enable before started), crank disconnect. After 10s' safety delay, idle delay begins. When idle delay is over, idle/high speed relay closes and genset runs in high speed.

Note: during crank rest delay, fuel relay disconnect, and 3s' delay begins. Once delay is over, ETS output disconnects, fuel outputs and preheat output will disconnect before cranking.

- ◆ When remote start input is disabled, enter into idle process after 10s' delay, idle/high speed output disconnects. After idle delay, fuel disconnects, ETS outputs and genset stops automatically. When genset at rest, ETS and idle output disconnect.

◆ In this mode, preheat key , start key  and set key  are disabled.









5 ALARM





- 1) Low Oil Pressure: After crank disconnect, detecting begins after delay 10s. Low OP lasts for 2s, alarm to shutdown.
- 2) High Temperature: After crank disconnect, detecting begins after delay 10s. High temperature lasts for 2s, alarm to shutdown.
- 3) Over Speed: detect when crank disconnect. Over speed lasts for 1.5s, alarm to shutdown.
- 4) Charge Fail: detect when high speed running. When D+ (WL) voltage under 3V and lasts for 3s, warn, not shutdown.
- 5) Auxiliary Stop Alarm: detect in Auto mode and Manual mode, do not detect in stop mode.
- 6) Fail to Start: under normal condition, fail to start within 3 times.
- 7) Fail to Stop: active when fuel signal has disconnected 30s, but genset not stop.
- 8) Fail to Generate Electricity: after crank disconnect, detect when delay 10 seconds. If gens voltage under 15V and lasts for 5 seconds, alarm to shutdown.
- 9) Common Alarm: when over speed, high temperature, low oil pressure, auxiliary shutdown alarm, fail to generate electricity, fail to start, fail to stop happen, alarm annunciator illuminates, and common alarm outputs.





























6 SETTING



Setting contents include: Idle time, gens rated frequency, OP detecting “crank disconnect”, preheat time.

Setting procedures:

Turn the key to stop position (O), long pressing  key for 5s to enter into setting state. Press  key to choose setting items ( and  LED indicating). Press  key to select corresponding setting value. (,  and  LED indicating). See the below form,

Item						Set
Idle time	<input checked="" type="radio"/>	<input type="radio"/>	<input type="radio"/>	<input type="radio"/>	<input type="radio"/>	5 Seconds
			<input type="radio"/>	<input type="radio"/>	<input checked="" type="radio"/>	10 Seconds (<i>Default</i>)
			<input type="radio"/>	<input checked="" type="radio"/>	<input type="radio"/>	15 Seconds
			<input type="radio"/>	<input checked="" type="radio"/>	<input checked="" type="radio"/>	20 Seconds
			<input checked="" type="radio"/>	<input type="radio"/>	<input type="radio"/>	30 Seconds
			<input checked="" type="radio"/>	<input type="radio"/>	<input checked="" type="radio"/>	60 Seconds
			<input checked="" type="radio"/>	<input checked="" type="radio"/>	<input type="radio"/>	120 Seconds
			<input checked="" type="radio"/>	<input checked="" type="radio"/>	<input checked="" type="radio"/>	180 Seconds
Generator rated frequency	<input type="radio"/>	<input checked="" type="radio"/>	<input type="radio"/>	<input type="radio"/>	<input type="radio"/>	50Hz (<i>Default</i>)
			<input type="radio"/>	<input type="radio"/>	<input checked="" type="radio"/>	60Hz
Oil pressure detect “crank disconnect”	<input checked="" type="radio"/>	<input checked="" type="radio"/>	<input type="radio"/>	<input type="radio"/>	<input type="radio"/>	Disable
			<input type="radio"/>	<input type="radio"/>	<input checked="" type="radio"/>	Enable (<i>Default</i>)

Item						Set
Pre-heat time						0 Seconds (<i>Default</i>)
						5 Seconds
						10 Seconds
						20 Seconds
						30 Seconds
						60 Seconds
						120 Seconds

Note: a)  for light illuminates,  for light not illuminate.

b) After setting, turn the key to stop position () to exit setting state.

c) If programmable output is set as common alarm, idle delay is 0.

7 TERMINALS FUNCTION

- ◆ Terminal 1 (B-): Connected to plant battery negative.
- ◆ Terminal 2 (B+): Connected to plant battery positive.
- ◆ Terminal 3 (Fuel Output): Fuel Output (B+), Connected to fuel relay.
- ◆ Terminal 4 (Start Output): Start Output (B+), Connected to start relay.
- ◆ Terminal 5 (Pre-heat Output): Pre-heat Output (B+).
- ◆ Terminal 6 (Aux. Shutdown Input): auxiliary shutdown alarm input, connect to B- active.
- ◆ Terminal 7 (D+): Connect to alternator WL (or D+) terminal. When charging fails (D+ voltage < 3V), annunciator on the panel illuminates. (indication only, not shutdown)
- ◆ Terminal 8 (Low Oil Pressure Input): Low Oil Pressure Input port, connect B- active.
- ◆ Terminal 9 (High Engine Temp input): High water/cylinder temperature input port, connect to B- active.
- ◆ Terminal 10 (L), 11(N): Connect to AC voltage signal for detecting crank disconnect and over speed protection.
- ◆ Terminal 12 (Config. Output): Config. Output (B+), can be set as idle/high speed output or common alarm via dial switch of the controller.
- ◆ Terminal 13 (Stop Output): Energize to stop (ETS) (B+).
- ◆ Terminal 14 (Remote Start Input): Remote start input port, connect to B- active.

8 TYPICAL APPLICATION

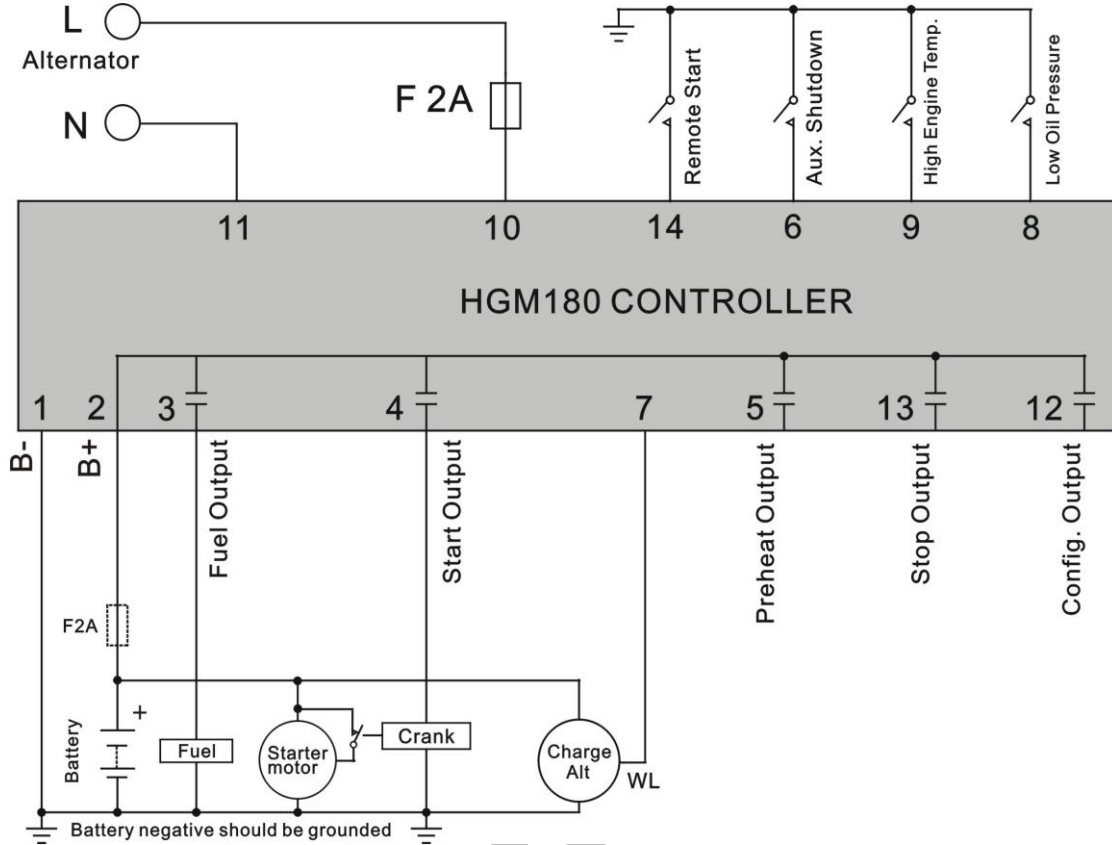

9 CASE DIMENSIONS (Panel Cutout 78 mm*66mm)

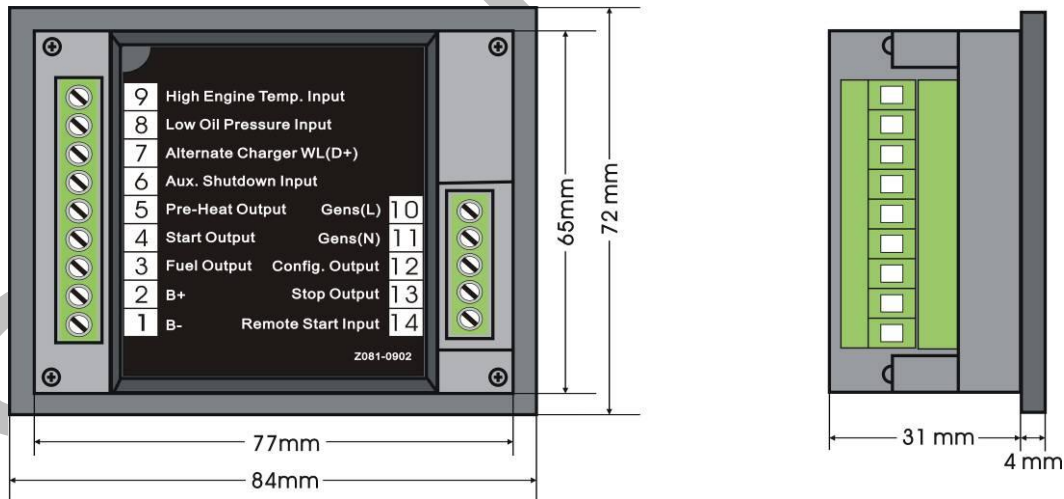

9.1 Battery Voltage Input

HGM180HC can be applicable to (8-35) VDC battery voltage environment; battery negative must be reliability connected to engine shell. The connection of controller power supply B+ and B- to battery poles should not be less than 2.5mm², if there is the float charger, please directly connect the charger output wire to battery poles, and then separately connect the wirings from the battery poles to the power supply output of the controller in case that the charger will interfere with the normal operation of the controller.

9.2 Output and Expansion Relay

All output of the controller is relay contacts output, if there is need to expand

output relays, please expand follow current diode in both ends of the relay coil (when extended relay coil links DC) or increase resistance and capacitance loop (when extended relay coil links AC) in order to prevent interference with the controller or other equipments.

9.3 Withstand Voltage Test

When the controller has been installed in the control panel, if you want to have Withstand voltage test, please disconnect all terminals in the controller lest high voltage damages the controller.

10 FAULT FINDING

Fault	Remedy
Controller no response with power.	Check starting batteries; Check controller connection wirings; Check DC fuse.
Genset shutdown	Check the water/cylinder temperature is high; Check the genset AC voltage; Check DC fuse.
Low oil pressure alarm after crank disconnect	Check the oil pressure sensor and its connections.
High water/cylinder temp alarm after crank disconnect	Check the temperature sensor and its connections.
Crank not disconnect	Check fuel oil circuit and its connections; Check starting batteries; Check speed sensor and its connections; Refer to engine manual.
Starter no response	Check starter connections; Check starting batteries.