

PAF200 Series

AIR UNITS (F.R.L.UNIT)

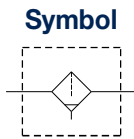

Specifications

Model	PAF200	
Bore No.	01	02
Port size	1/8	1/4
Medium	Air	
Operating pressure range	0.05~1 MPa	
Proof pressure	1.5 MPa	
Ambient temperature	-5 ~ +60°C (No freezing)	
Filter element	Standard: 5µm Option: 40µm	
Weight	187g,155g(PAF200L)	

※ Standard unit contains semi-auto-drain function when operating pressure below 0.05 MPa.

Order example

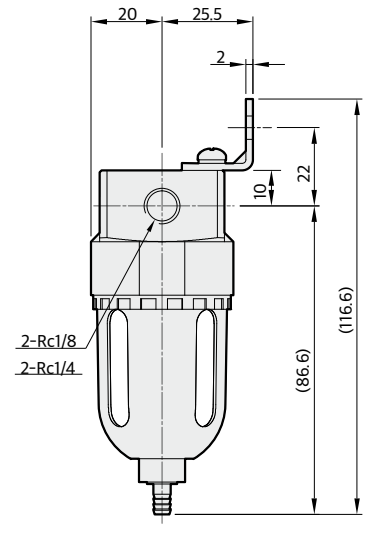
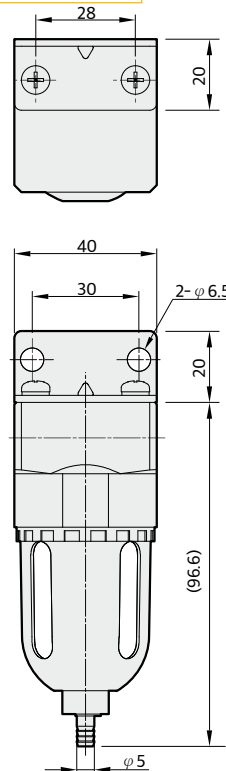
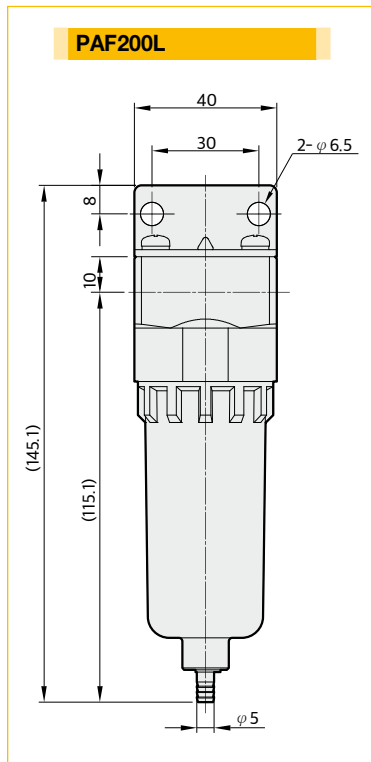
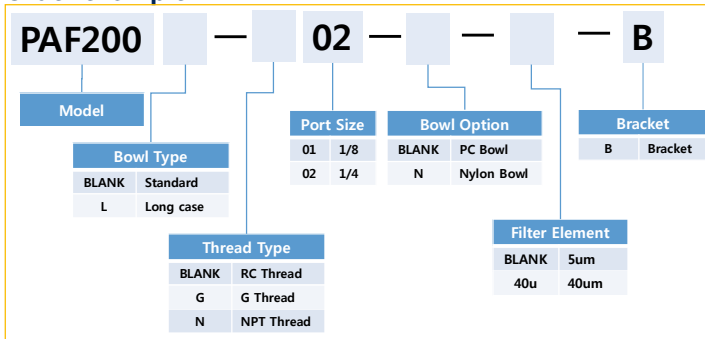

PAF302 Series

AIR UNITS (F.R.L.UNIT)



Symbol

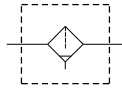

Specifications

Model	PAF302		
Bore No.	02	03	04
Port size	1/4	3/8	1/2
Medium	Air		
Operating pressure range(※)	0.05~1 MPa		
Proof pressure	1.5 MPa		
Ambient temperature	-5 ~ +60°C (No freezing)		
Filter element	Standard: 5μm Option: 40μm		
Weight	335 g		

※ 1. Standard unit contains semi-auto-drain function when operating pressure below 0.05 MPa.

※ 2. Choose auto-drain PMRF300, the pressure range is 0.15 ~ 1 MPa.

Order example

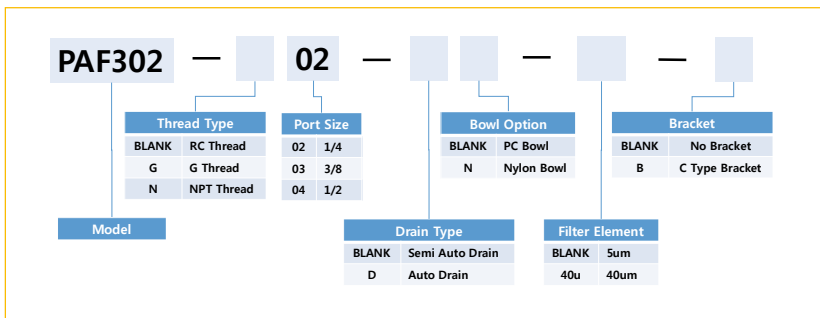

Option accessories

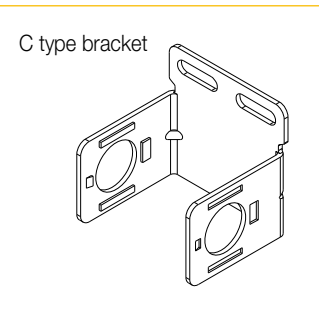

PAF302-D

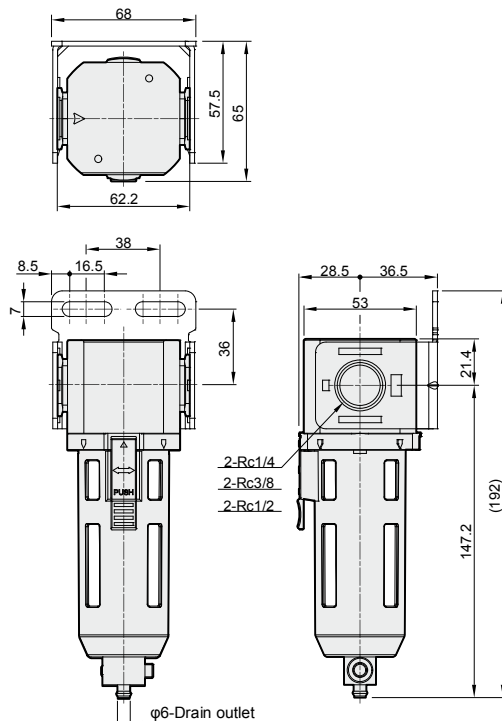
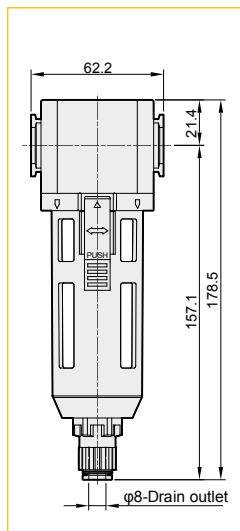

Flow feature

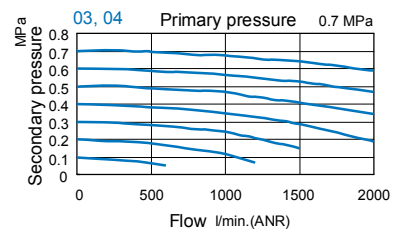
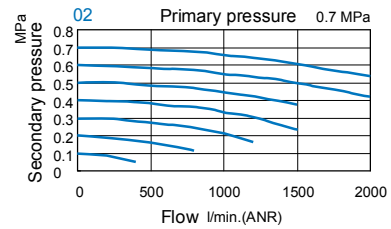

PAF403 Series

AIR UNITS (F.R.L.UNIT)



Symbol

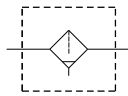

Specifications

Model	PAF403		
Bore No.	02	03	04
Port size	1/4	3/8	1/2
Medium	Air		
Operating pressure range(※)	0.05~1 MPa		
Proof pressure	1.5 MPa		
Ambient temperature	-5 ~ +60°C (No freezing)		
Filter element	Standard: 5µm Option: 40µm		
Weight	345 g		

- ※ 1. Standard unit contains semi-auto-drain function when operating pressure below 0.05 MPa.
- ※ 2. Choose auto-drain PMRF300, the pressure range is 0.15~1MPa.

Order example

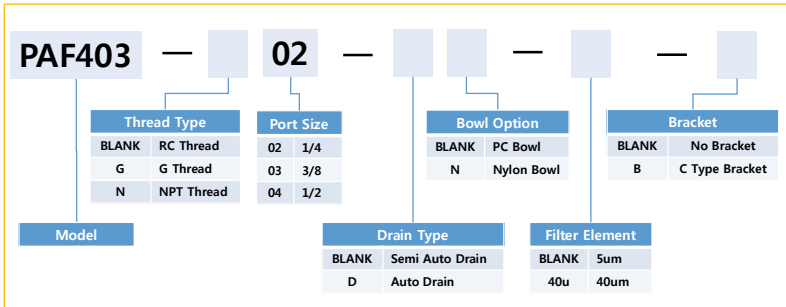

Option accessories

C type bracket

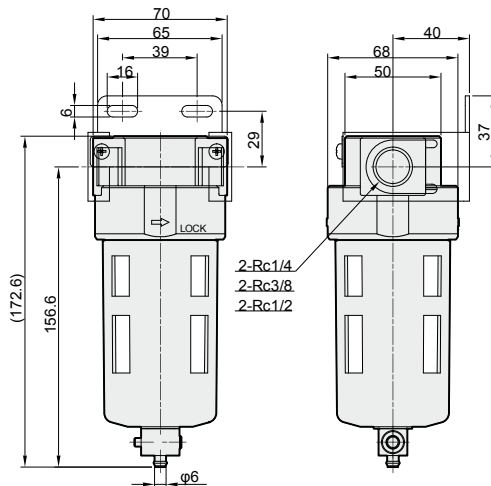
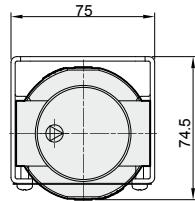
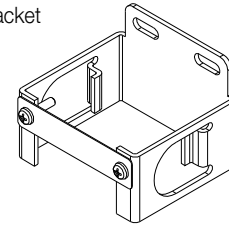

Flow feature

