

PCA200 Series

AIR UNITS (F.R.L.UNIT)

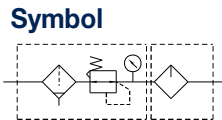

Specifications

Model	PCA200	
Components	PFR200, PAL200	
Bore No.	01	02
Port size	1/8	1/4
Medium	Air	
Operating pressure range(※)	0.05~1 MPa	
Proof pressure	1.5 MPa	
Regulated pressure range	0.05~0.85MPa	
Ambient temperature	-5 ~ 60°C (No freezing)	
Filter element	Standard: 5µm Option: 40µm	
Lubricating oil capacity	20c.c, 35c.c (PCA200L)	
Min. flow for oil drip	35 l/min	50 l/min
Recommended lubricating oil	Turbine oil ISO-VG32	
Attachment	Pressure gauge(PG-40),	
Weight	432g, 380g (PCA200L)	

※ Standard unit contains semi-auto-drain function when operating pressure below 0.05 MPa.

Order example

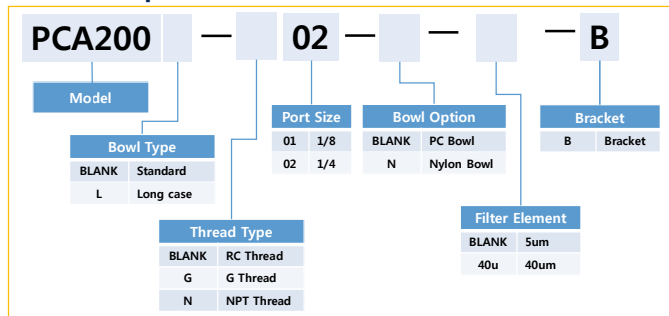

Flow feature

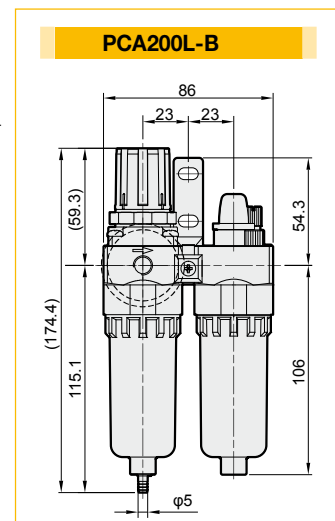
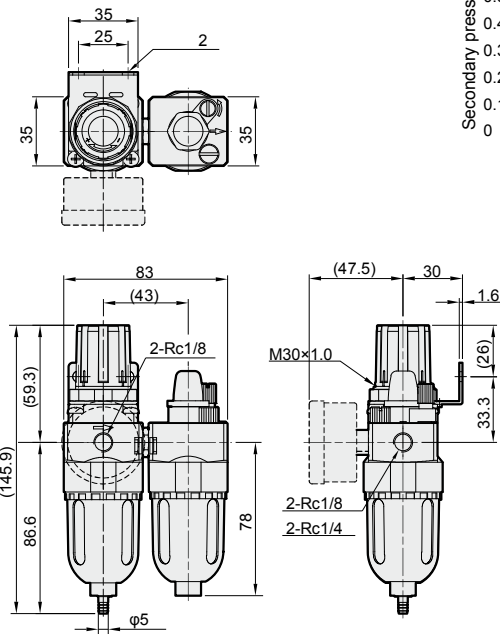
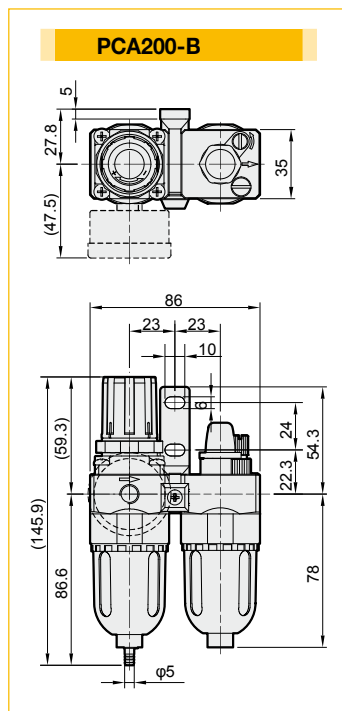
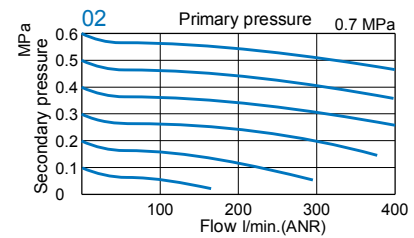
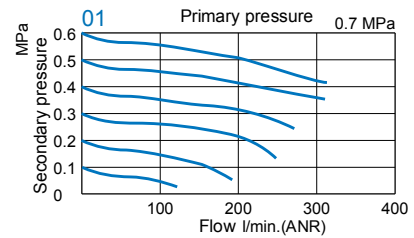

PCA302 Series

AIR UNITS (F.R.L.UNIT)



Symbol

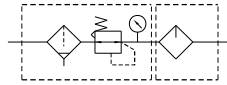

Specifications

Model	PCA302		
Components	PFR302, PAL302		
Bore No.	02	03	04
Port size	1/4	3/8	1/2
Medium	Air		
Operating pressure range(※)	0.05~1 MPa		
Proof pressure	1.5 MPa		
Regulated pressure range	0.05~0.85 MPa		
Ambient temperature	-5 ~ +60°C (No freezing)		
Filter element	Standard: 5µm Option: 40µm		
Lubricating oil capacity	65c.c		
Min. flow for oil drip	50 l/min	60 l/min	
Recommended lubricating oil	Turbine oil ISO-VG32		
Attachment	Pressure gauge (PG-20), T-type Bracket		
Weight	845 g		

※ 1. Standard unit contains semi-auto-drain function when operating pressure below 0.05 MPa

※ 2. Choose auto-drain PMRF300, the pressure range is 0.15~1 MPa.

Order example

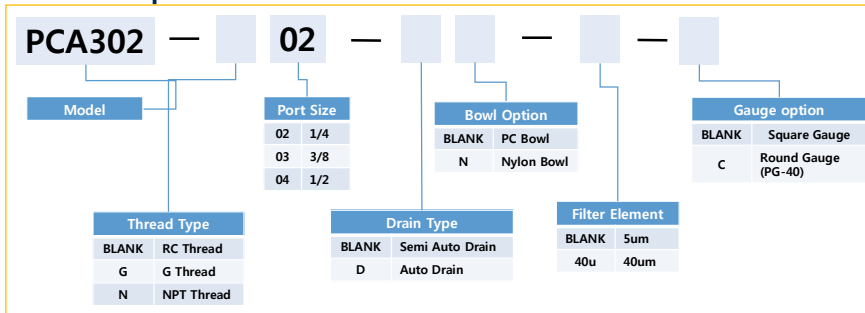

Flow feature

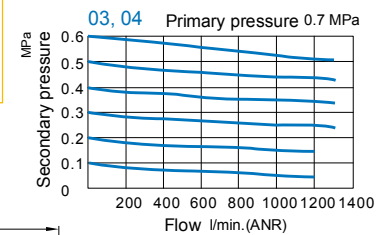
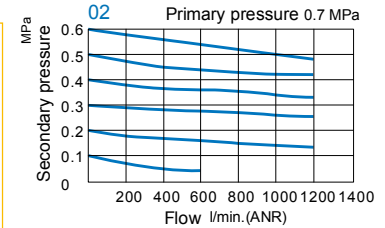

PCA302T* Module mounting bracket

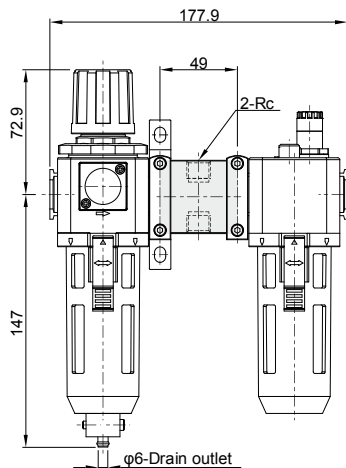

PCA302-D Auto drain valve

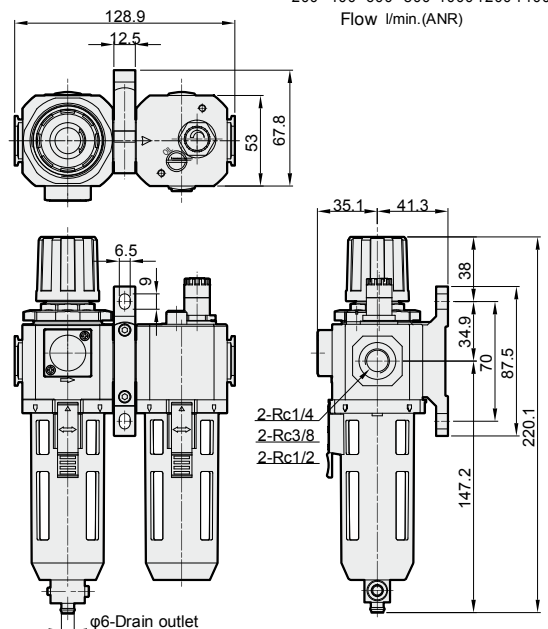
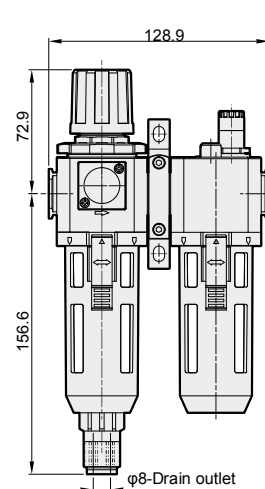

PCA403 Series

AIR UNITS (F.R.L.UNIT)



Symbol

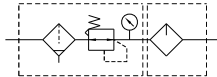

Specifications

Model	PCA403		
Components	PFR403, PAL403		
Bore No.	02	03	04
Port size	1/4	3/8	1/2
Medium	Air		
Operating pressure range(※)	0.05~1 MPa		
Proof pressure	1.5 MPa		
Regulated pressure range	0.1~0.85MPa		
Ambient temperature	-5 ~ +60°C (No freezing)		
Filter element	Standard: 5µm Option: 40µm		
Lubricating oil capacity	140c.c		
Min. flow for oil drip	30 l/min	65 l/min	80 l/min
Recommended lubricating oil	Turbine oil ISO-VG32		
Attachment	Pressure gauge(PG-20), L-type Bracket		
Weight	1100 g		

- ※ 1. Standard unit contains semi-auto-drain function when operating pressure below 0.05 MPa
- ※ 2. Choose auto-drain PMRF300, the pressure range is 0.15 ~ 1 MPa.

Order example

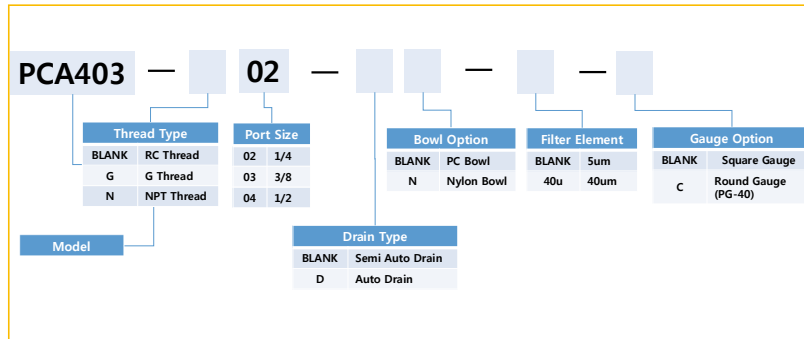

Flow feature

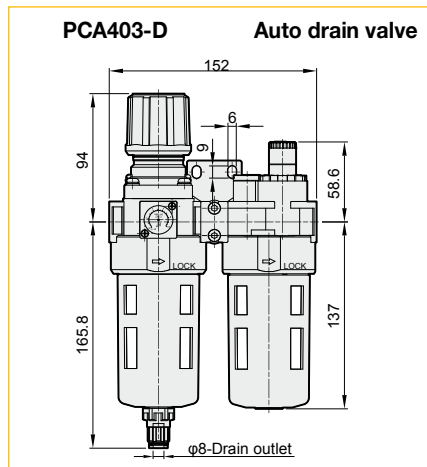
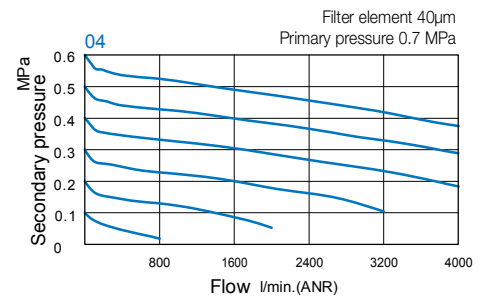
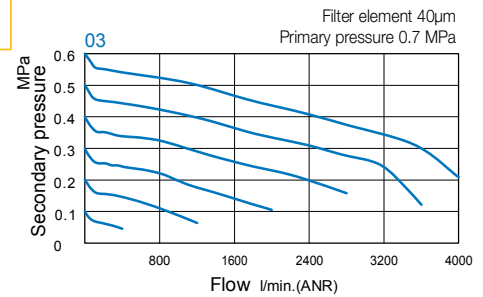
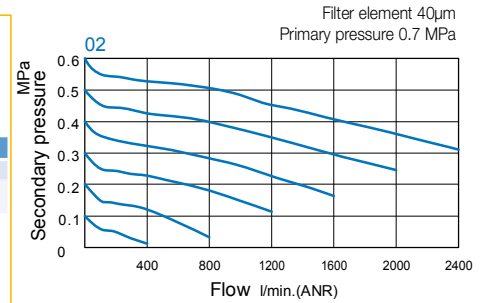

PCA403 Dimensions

AIR UNITS (F.R.L.UNIT)

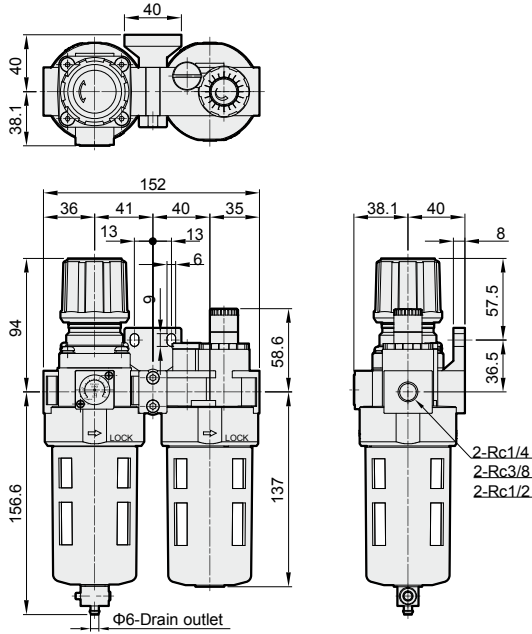

PCA403-T*

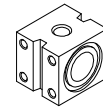
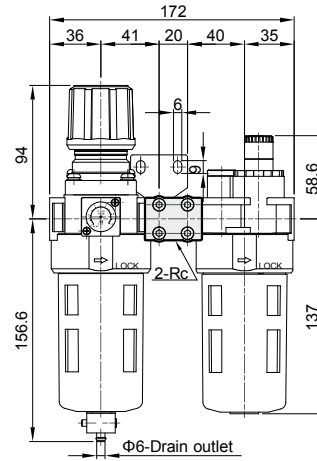

	Rc
T8	Rc1/4
T10	Rc3/8
T15	Rc1/2

PCA403-K*

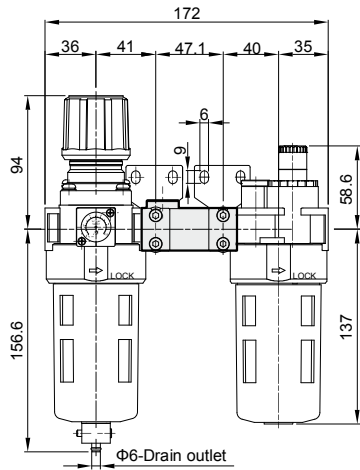

PCA403-P*

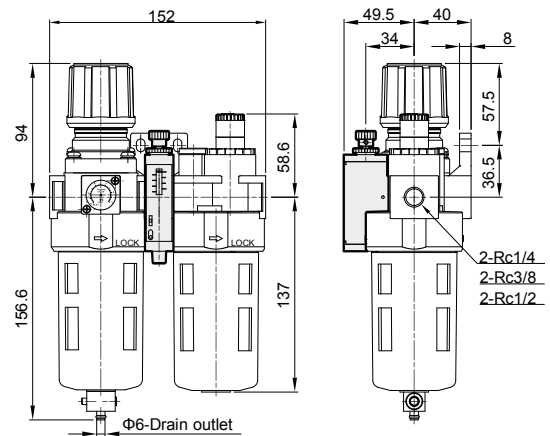

MPS Series
pneumatic pressure switch

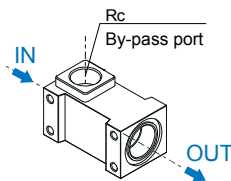

	Rc
K8	Rc1/4
K10	Rc3/8

※ Threads for IN and OUT ports aren't machined.