

Truy cập website <https://plcmitsubishi.com> để có thêm nhiều tài liệu và bài viết hướng dẫn kỹ thuật hay

Changes for the Better

 **MITSUBISHI**
PROGRAMMABLE CONTROLLERS
MELSEC-F

HARDWARE MANUAL

FX1S SERIES PROGRAMMABLE CONTROLLERS

FX1S



Foreword

- This manual contains text, diagrams and explanations which will guide the reader in the correct installation and operation of the FX1S Series Programmable Controllers. It should be read and understood before attempting to install or use the unit.
- Further information can be found in the FX Series Programming Manual II.
- If in doubt at any stage of the installation of an FX1S Series Programmable Controller always consult a professional electrical engineer who is qualified and trained to the local and national standards which apply to the installation site.
- If in doubt about the operation or use of FX1S Series Programmable Controller please consult the nearest Mitsubishi Electric distributor.
- This manual is subject to change without notice.



FX₁S Series Programmable Controllers

Hardware Manual

Manual number : JY992D83901

Manual revision : G

Date : March 2003

Guidelines for the Safety of the User and Protection of the FX1s.

This manual provides information for the use of the FX1s. The manual has been written to be used by trained and competent personnel. The definition of such a person or persons is as follows:

- a) Any engineer who is responsible for the planning, design and construction of automatic equipment using the product associated with this manual, should be of a competent nature, trained and qualified to the local and national standards required to fulfill that role. These engineers should be fully aware of all aspects of safety with regards to automated equipment.
- b) Any commissioning or service engineer must be of a competent nature, trained and qualified to the local and national standards required to fulfill that job. These engineers should also be trained in the use and maintenance of the completed product. This includes being completely familiar with all associated documentation for said product. All maintenance should be carried out in accordance with established safety practices.
- c) All operators of the completed equipment (see Note) should be trained to use this product in a safe manner in compliance to established safety practices. The operators should also be familiar with documentation which is associated with the operation of the completed equipment.

Note : The term ‘completed equipment’ refers to a third party constructed device which contains or uses the product associated with this manual.

Notes on the Symbols Used in this Manual

At various times throughout this manual certain symbols will be used to highlight points which are intended to ensure the users personal safety and protect the integrity of equipment. Whenever any of the following symbols are encountered its associated note must be read and understood. Each of the symbols used will now be listed with a brief description of its meaning.

Hardware Warnings



1) Indicates that the identified danger **WILL** cause physical and property damage.



2) Indicates that the identified danger could **POSSIBLY** cause physical and property damage.



3) Indicates a point of further interest or further explanation.

Software Warnings



4) Indicates special care must be taken when using this element of software.



5) Indicates a special point which the user of the associate software element should be aware.



6) Indicates a point of interest or further explanation.

- Under no circumstances will Mitsubishi Electric be liable responsible for any consequential damage that may arise as a result of the installation or use of this equipment.
- All examples and diagrams shown in this manual are intended only as an aid to understanding the text, not to guarantee operation. Mitsubishi Electric will accept no responsibility for actual use of the product based on these illustrative examples.
- Please contact a Mitsubishi Electric distributor for more information concerning applications in life critical situations or high reliability.

Associated Manuals

The following manuals are recommended as essential reference material for the correct operation of a FX1S series Programmable controller.

Manual Name	Manual Number	Description
FX Programming Manual II	JY992D88101	This manual contains instruction explanation about FX1S, FX1N, FX2N and FX2NC Series PLC.
FX Communication User's Manual	JY992D69901	This manual contains explanation for N:N network, parallel link, no protocol communication and computer link
FX1N-5DM User's Manual	JY992D84901	This manual contains hardware explanation for installation, specification and operation.
FX-10DM-E User's Manual	JY992D86401	This manual contains hardware explanation for installation, specification and operation.
FX1N-422-BD Users Manual	JY992D84101	This manual contains hardware explanation for installation and specification.
FX1N-485-BD Users Manual	JY992D84201	This manual contains hardware explanation for installation and specification.
FX1N-232-BD Users Manual	JY992D84401	This manual contains hardware explanation for installation and specification.
FX1N-4EX-BD Users Manual	JY992D95001	This manual contains explanation for installation, specification and special auxiliary relay allocation.
FX1N-2EYT-BD Users Manual	JY992D95201	This manual contains explanation for installation, specification and special auxiliary relay allocation.

Manual Name	Manual Number	Description
FX1N-2AD-BD Users Manual	JY992D96201	This manual contains explanation for installation, specification and special auxiliary relay allocation.
FX1N-1DA-BD Users Manual	JY992D96401	This manual contains explanation for installation, specification and special auxiliary relay allocation.
FX1N-8AV-BD	JY992D84601	This manual contains hardware explanation for installation and specification.
FX1N-CNV-BD	JY992D84701	This manual contains explanation for installation.

Table of Contents

Guideline	ii
Associated Manuals	v
1. Introduction.....	1-1
1.1 Model Name	1-5
1.2 World Specification.....	1-6
1.3 Serial Numbers.....	1-7
1.4 Configuration	1-8
1.4.1 Note for Using Expansion Board	1-11
1.5 Backup Data	1-12
1.5.1 Data Backup.....	1-12
1.5.2 Capacitor backup	1-12
2. Terminal Layouts.....	2-1
2.1 FX1S-**MR-ES/UL	2-1
2.2 FX1S-**MR-DS.....	2-2
2.3 FX1S-**MT-DSS.....	2-3
2.4 FX1S-**MT-ESS/UL	2-4

3. Installation Notes	3-1
3.1 Product Outline	3-2
3.2 FX1S RUN/STOP Control	3-3
3.3 General Specifications.....	3-4
3.4 PLC Mounting Arrangements	3-5
3.5 DIN Rail Mounting	3-8
3.6 Direct Mounting	3-8
3.7 Termination of Screw Terminals.....	3-9
3.8 Installing Optional Units.....	3-12
3.8.1 Expansion Boards	3-12
3.8.2 FX1N-5DM Display Module.....	3-14
4. Power Supply	4-1
4.1 Wiring Techniques.....	4-1
4.2 Wiring Cautions	4-1
4.3 Power Supply	4-2
4.4 Power Supply Characteristics.....	4-3
4.5 Power Supply Wiring	4-5
4.6 Service Power supply	4-7
4.7 Earthing / Grounding	4-7

5. Inputs.....	5-1
5.1 24V DC Input Specifications.....	5-1
5.2 Wiring Diagrams.....	5-2
5.2.1 Input Wiring.....	5-2
5.2.2 Input Circuit Connection.....	5-3
5.2.3 Diodes and Inputs Connected in Series.....	5-3
5.2.4 Resistors and Inputs Connected in Parallel.....	5-4
6. Outputs.....	6-1
6.1 Output Specifications.....	6-1
6.2 Relay Output Example.....	6-2
6.2.1 Reliability Tests.....	6-3
6.3 Transistor Output Examples.....	6-4
6.3.1 Response Times.....	6-5
0.1 Applying Safe Loads.....	6-6

7. Diagnostics	7-1
7.1 Preliminary Checks.....	7-1
7.2 ERROR LED ON (CPU ERROR)	7-2
7.3 Common Errors	7-3
7.4 Maintenance	7-3
7.5 Operation and Error Flags	7-4
7.6 PLC Status Registers	7-5
7.7 Error Registers	7-6
7.8 Error Codes	7-7
7.9 Instruction List	7-8
7.10 Device List	7-11

1	INTRODUCTION	1
2	TERMINAL LAYOUTS	2
3	INSTALLATION NOTES	3
4	POWER SUPPLY	4
5	INPUTS	5
6	OUTPUTS	6
7	DIAGNOSTICS	7

1	INTRODUCTION
2	TERMINAL LAYOUTS
3	INSTALLATION NOTES
4	POWER SUPPLY
5	INPUTS
6	OUTPUTS
7	DIAGNOSTICS

1. Introduction

This manual covers the hardware installation instructions for the FX1S Series Programmable (Logic) Controller.

Table 1.1: AC Power, Relay Output Units

MODEL	INPUT		OUTPUT		POWER SUPPLY	DIMENSIONS mm (inches)			MASS (WEIGHT) kg (lbs)
	QTY	TYPE	QTY	TYPE					
FX1S-10MR-ES/UL	6	24V DC Sink / Source	4	Relay	85 - 264 VAC	60	90	75	0.30
FX1S-14MR-ES/UL	8		6			(2.37)			(0.66)
FX1S-20MR-ES/UL	12		8			(2.96)			(0.88)
FX1S-30MR-ES/UL	16		14			(3.94)			(0.99)

Table 1.2: AC Power Transistor Output Units

MODEL	INPUT		OUTPUT		POWER SUPPLY	DIMENSIONS mm (inches)			MASS (WEIGHT) kg (lbs)
	QTY	TYPE	QTY	TYPE					
FX1S-10MT-ESS/UL	6	24V DC Sink / Source	4	Transistor (Source)	85 - 264 VAC	60	90	75	0.3
FX1S-14MT-ESS/UL	8		6			(2.37)			(0.66)
FX1S-20MT-ESS/UL	12		8			(2.96)			(0.88)
FX1S-30MT-ESS-UL	16		14			(3.94)			(0.99)



Table 1.3: DC Power, Relay Output Units

MODEL	INPUT		OUTPUT		POWER SUPPLY	DIMENSIONS mm (inches)			MASS (WEIGHT) kg (lbs)
	QTY	TYPE	QTY	TYPE					
FX1s-10MR-DS	6	24V DC Sink / Source	4	Relay	24 VDC +10, -15%	60 (2.37)	90 (3.55)	49 (1.93)	0.22 (0.48)
FX1s-14MR-DS	8		6			0.30 (0.66)			
FX1s-20MR-DS	12		8			0.35 (0.77)			
FX1s-30MR-DS	16		14						

Table 1.4: DC Power Transistor Output Units

MODEL	INPUT		OUTPUT		POWER SUPPLY	DIMENSIONS mm (inches)			MASS (WEIGHT) kg (lbs)
	QTY	TYPE	QTY	TYPE					
FX1s-10MT-DSS	6	24V DC Sink / Source	4	Transistor (Source)	24 VDC +10, - 15%	60 (2.37)	90 (3.55)	49 (1.93)	0.22 (0.48)
FX1s-14MT-DSS	8		6			0.30 (0.66)			
FX1s-20MT-DSS	12		8			0.35 (0.77)			
FX1s-30MT-DSS	16		14						

Figure 1.1: FX1S Outline Drawing

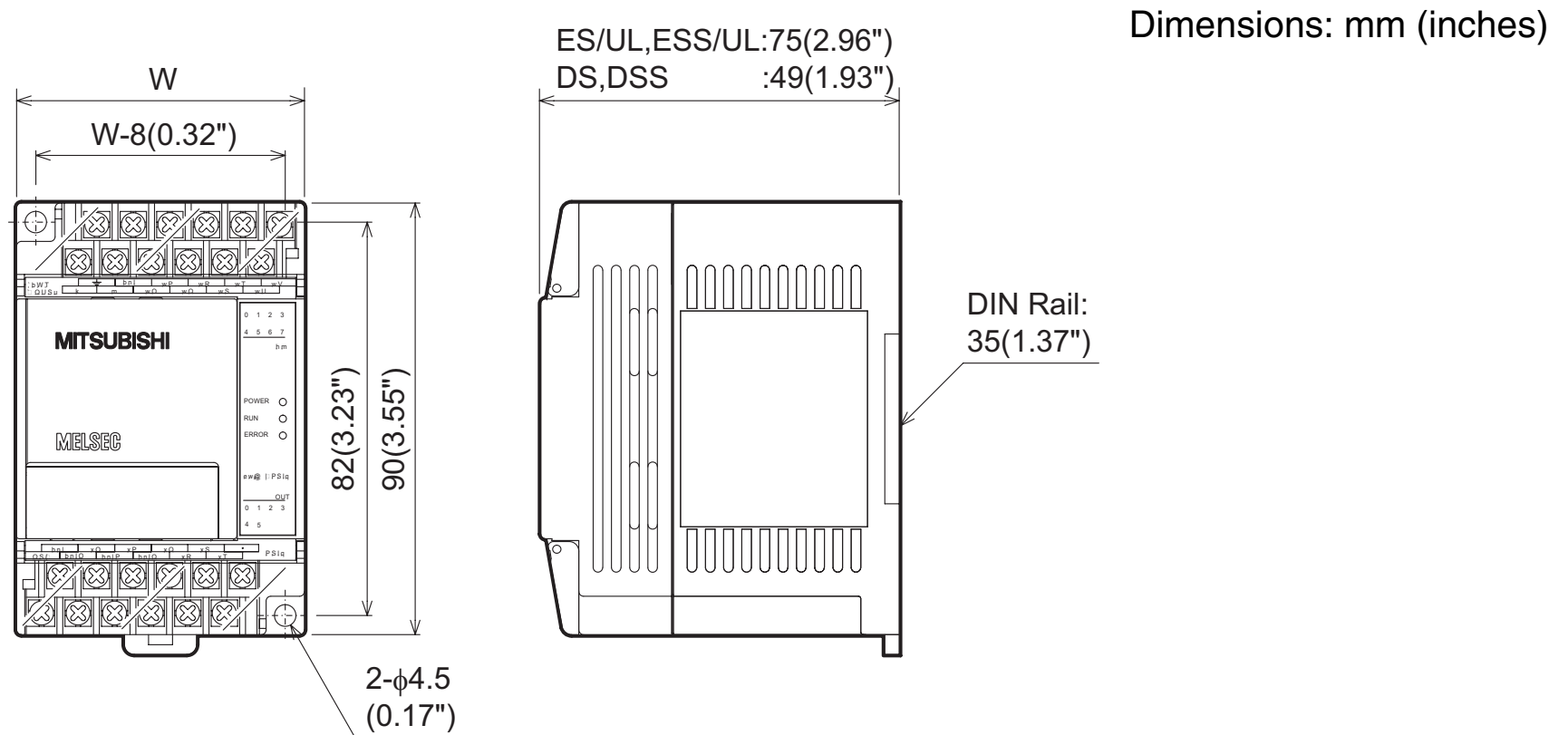

The distance between the vertical centerlines is 8mm (0.32") less than the width of the unit. Please see previous page for each model's width measurement.

- 1
- 2
- 3
- 4
- 5
- 6
- 7

Table 1.5: Expansion Board and Communication Adapter

MODEL	DESCRIPTION	POWER SUPPLY (External 24V DC)	DIMENSIONS			MASS (WEIGHT) kg (lbs)
FX1N-4EX-BD	Four point special input	-	Mounts directly into top of PLC			Mounts directly into top of PLC
FX1N-2EYT-BD	Two point special output	-				
FX1N-2AD-BD	Two channel special analog to digital converter	-				
FX1N-1DA-BD	One channel special digital to analog converter	-				
FX1N-232-BD	RS-232C communication interface	-				
FX1N-422-BD	RS-422 communication interface	-				
FX1N-485-BD	RS-485 communication interface	-				
FX1N-8AV-BD	Analog potentiometer	-				
FX1N-CNV-BD	Communication adapter connection interface	-				
FX2NC-232ADP*1	RS-232C communication adapter	-	19.1 (0.76)	90 (3.55)	85 (3.35)	0.1 (0.22)
FX0N-232ADP*1	RS-232C communication adapter	-	43 (1.70)		68 (2.68)	
FX2NC-485ADP*1	RS-485 communication adapter	-	19.1 (0.76)		78 (3.08)	
FX0N-485ADP*1	RS-485 communication adapter	50mA	43 (1.70)		87 (3.43)	

*1 The communication adapter needs to connect via an FX1N-CNV-BD to the FX1S Series PLC.

1.1 Model Name

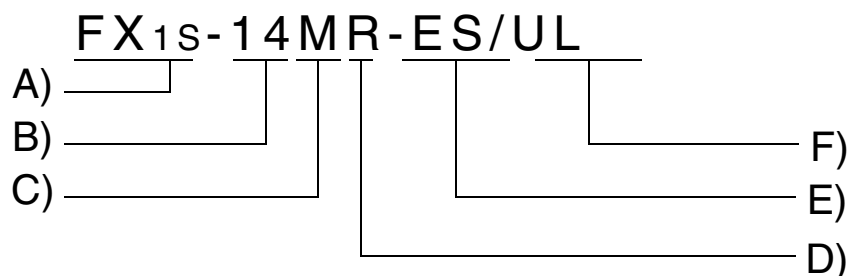

Table 1.6: Model Table

A)	PLC type: FX1S
B)	Total number of I / O channels
C)	Unit type
	M MPU - main unit
D)	Output type
	R Relay
	T Transistor

		Features
E)	Omit	AC Power Supply, Japanese specification
	D	DC Power Supply, Japanese specification
	DS	DC Power Supply, World specification, Relay Output, CE & UL Registered
	DSS	DC Power Supply, World specification, DC source transistor output, CE & UL Registered
	ES	AC Power Supply, World specification, relay output
	ESS	AC Power Supply, World Specification, DC Source Transistor Output
F)	UL	CE, UL registered product

1
2
3
4
5
6
7

1.2 World Specification

Table 1.7: World / Japanese Specifications

Input Sink / Source	World spec models: SINK / SOURCE Japanese models: ALWAYS SINK
Outputs Transistor	World spec models: ALWAYS SOURCE Japanese models: ALWAYS SINK

1.3 Serial Numbers

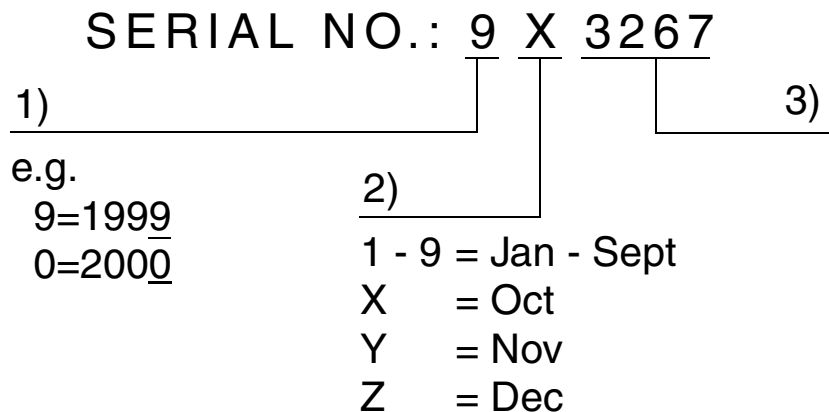

Table 1.8: Notes on Serial Numbers

1)	Production year
2)	Production month
3)	Production serial number

- 1
- 2
- 3
- 4
- 5
- 6
- 7

1.4 Configuration

Figure 1.2: Schematic System

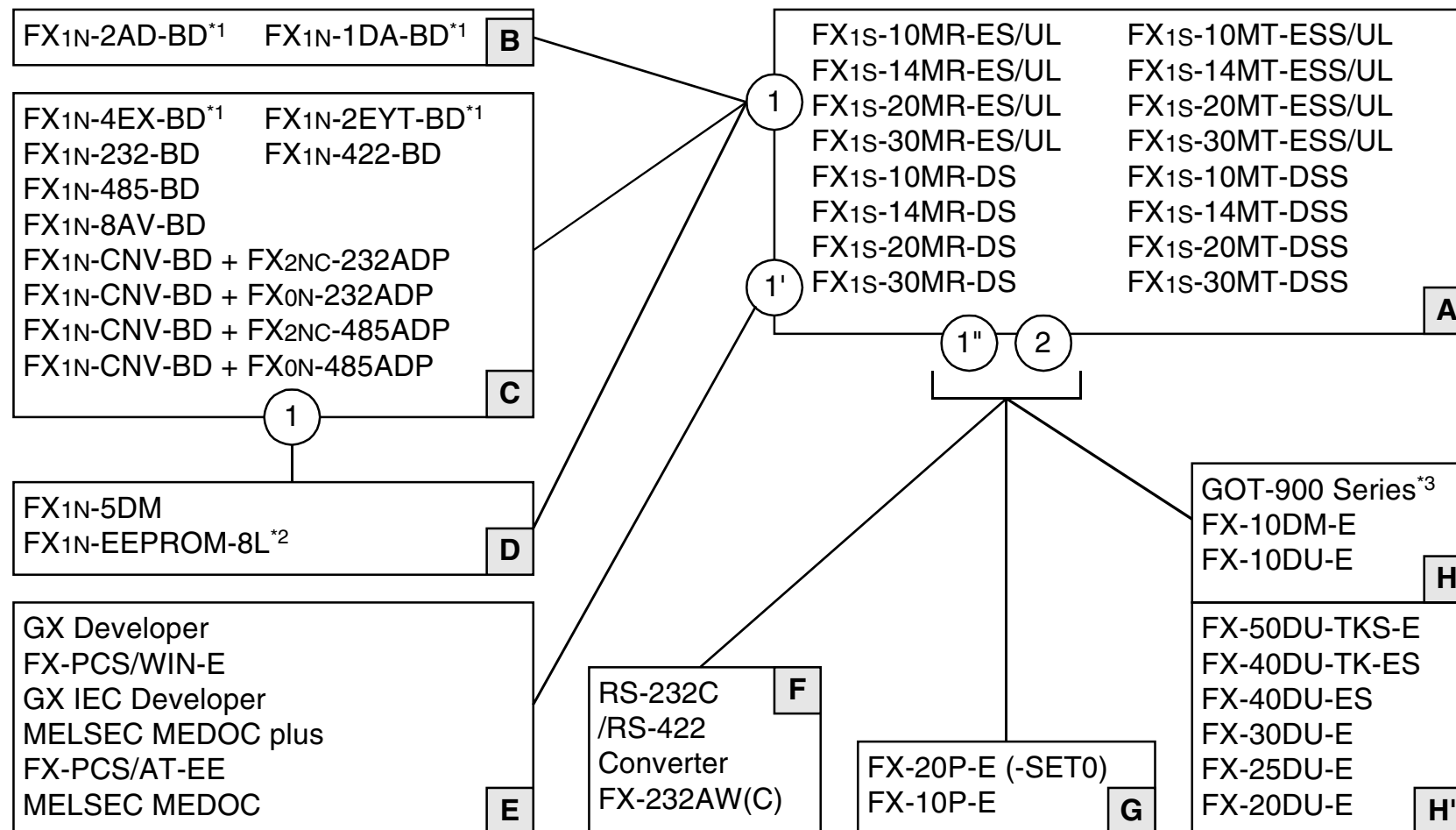

- *1 Available for use with FX_{1S} version 2.00 or later.
- *2 When using the FX_{1N}-EEPROM-8L with an expansion board in group C, only the loader function (transfer program) can be used. Remove it from the PLC after using the loader function and attach the top cover onto the PLC.
- *3 GOT-F900 Series can connect via an FX_{1N}-232-BD to the FX_{1S} PLC.

1

2

3

4

5

6

7

Table 1.9: Configuration Notes

A	FX1S Series Main Unit
B	FX1N Expansion Boards for Analog I/O
C	FX1N Expansion Boards without Analog I/O
D	Memory Cassette or Display Module
E	Programming Software
F	RS-232C/RS-422 Converter for PC
G	Dedicated Programming Tools
H	HMI Devices (GOT-F900/ GOT-A900/ DM/ DU) <GOT: Graphic Operation Terminal, DM: Display Module, DU: Data access Unit>
H'	DU Series (Discontinued since Sept. 2002)

Table 1.10: Connection Ports

1	Left hand side port
1'	Left hand side port + FX1N-232-BD or Left hand side port + FX1N-CNV-BD + FX2NC-232ADP or Left hand side port + FX1N-CNV-BD + FX0N-232ADP
1"	Left hand side port + FX1N-422-BD
2	Programming Port

1.4.1 Note for Using Expansion Board



The following conditions cannot be accomplished with an FX_{1S} PLC.

- FX_{1N}-422-BD + FX-2PIF
- FX_{1N}-5DM + FX_{1N}-422-BD + FX-10DM
- FX-10DM + FX_{1N}-422-BD + FX-10DM
- Connect two Programming tools (FX-10P-E, FX-20P-E, Programming software, etc.)
- The use of Special function Blocks



Caution

Connect a programming tool (such as an FX-10P-E, FX-20P-E and personal computer) to either the connector built in to the PLC or the connector on the FX_{1N}-422-BD or FX_{1N}-232-BD. If a programming tool is connected to both connectors, the program stored in the PLC may not match the program stored in the programming tool. If the program is changed or the set value of timers or counters are changed with this configuration, the program may be partially overwritten and the PLC may malfunction.

1

2

3

4

5

6

7

1.5 Backup Data

1.5.1 Data Backup

Data includes the Program, Comment, File Register (D1000 ~ D2499), and parameter data. This will be stored as long as the EEPROM is not damaged. Mitsubishi Electric has guaranteed a life cycle time of **10,000** writes to the EEPROM memory. Users may experience operational writes to the EEPROM in excess of 10,000; however, due to temperature effects a quantitative estimation cannot be given.

If the PLC has been powered ON for five minutes or more, the following device data will be saved in the EEPROM at power-down:

S0~S127, M384 ~ M511, C16 ~ C31, C235 ~ C255 and D128 ~ D255.

If the PLC is powered ON for less than 5 minutes, the above data is not saved!

1.5.2 Capacitor backup

Only the RTC is backed up by the capacitor.

The capacitor backed memory will retain data for 10 days. The capacitor requires 30 minutes to recharge upon power-up. There is no internal hardware reset function, thus, after a 10day duration the RTC data may be unfixed and not reset to 0.

2. Terminal Layouts

The following selection of terminal layouts are taken from the FX₁S product range.

Note: All layouts are schematic only and are intended to aid in the creation of wiring diagrams.

2.1 FX₁S-**MR-ES/UL

Figure 2.1: Terminal Layouts, Relay Outputs, AC Power

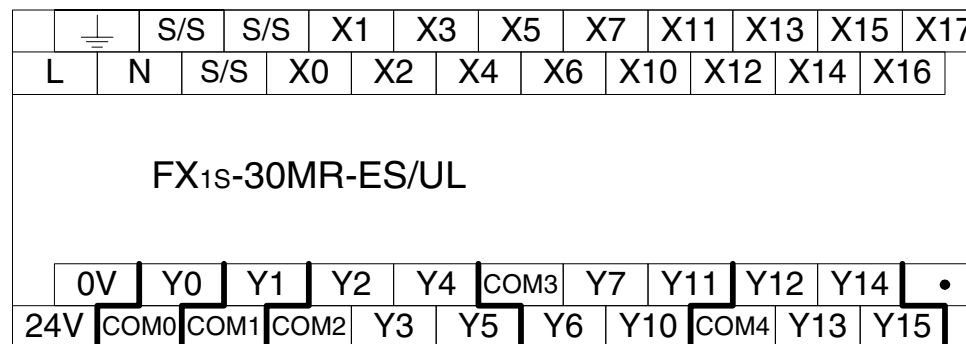
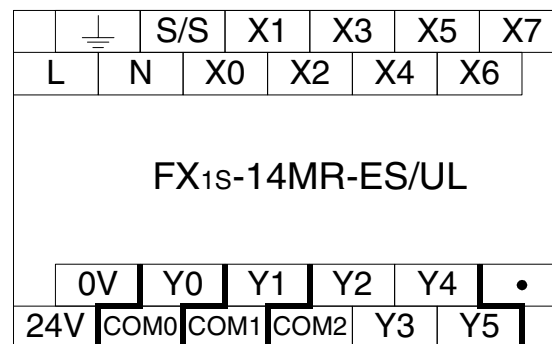
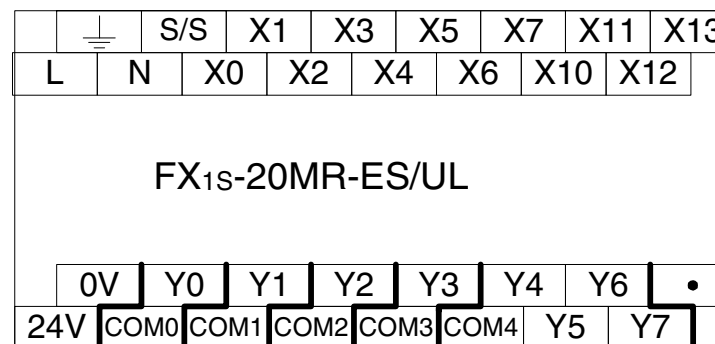
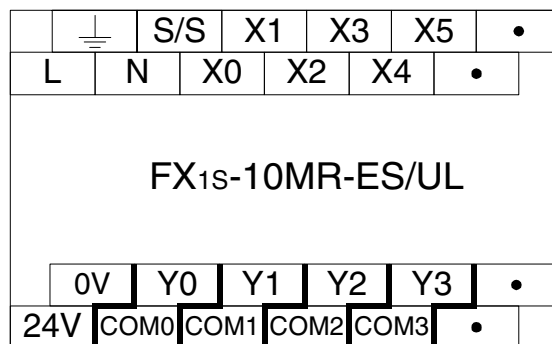

1

2

3

4

5

6

7

2.2 FX1S-**MR-DS

Figure 2.2: Terminal Layouts, Relay Outputs, DC Power

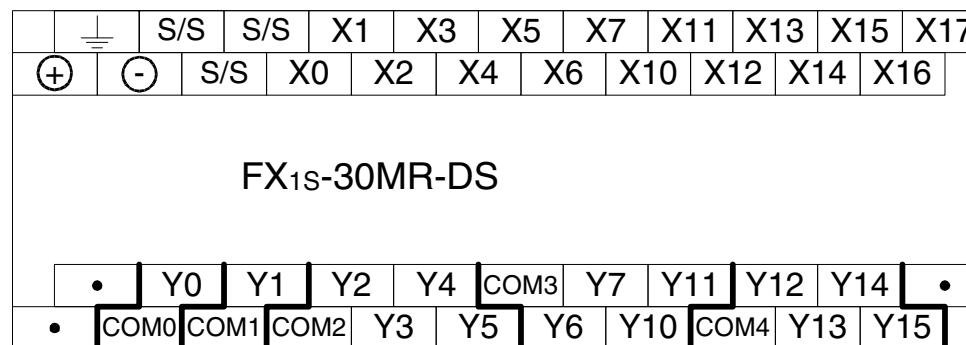
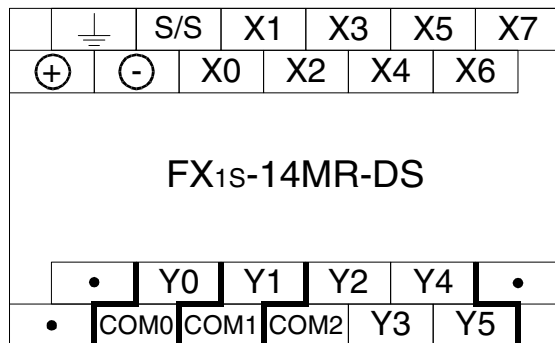
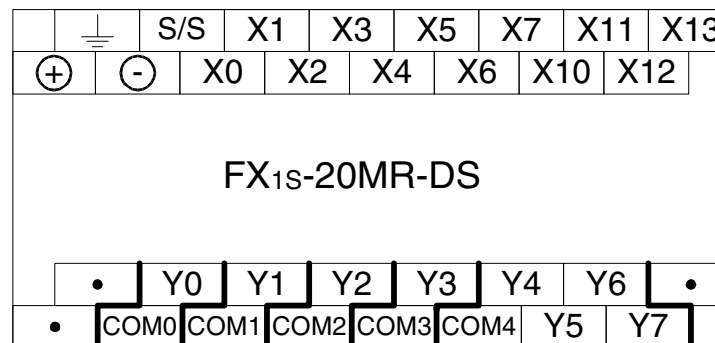
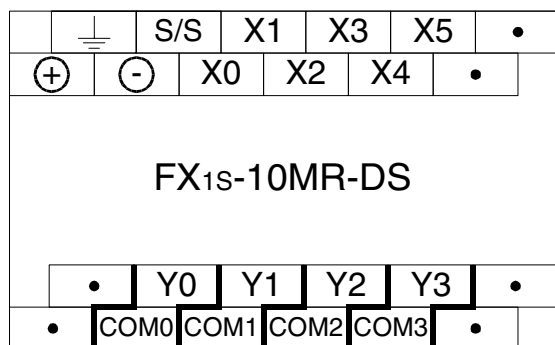

2.3 FX1S-**MT-DSS

Figure 2.3: Terminal Layouts, Transistor Outputs, DC Power

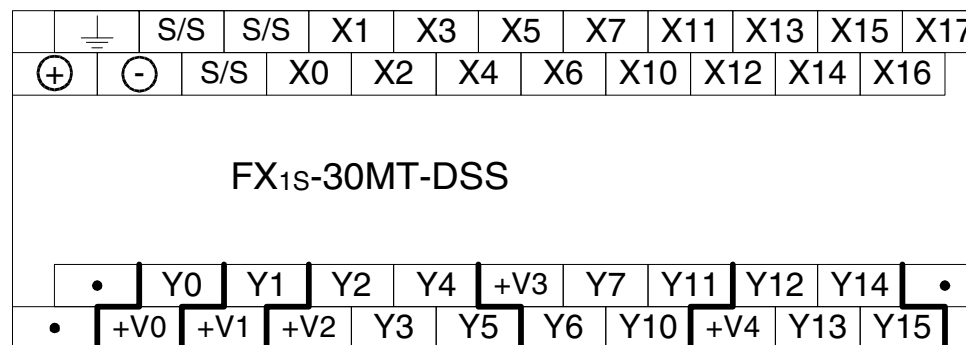
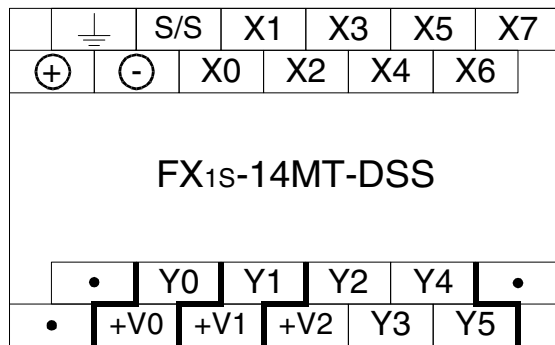
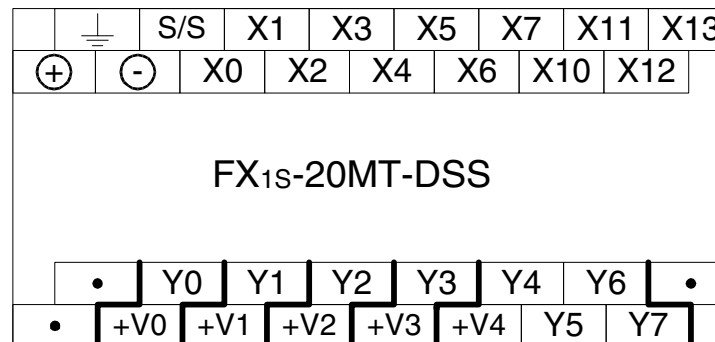
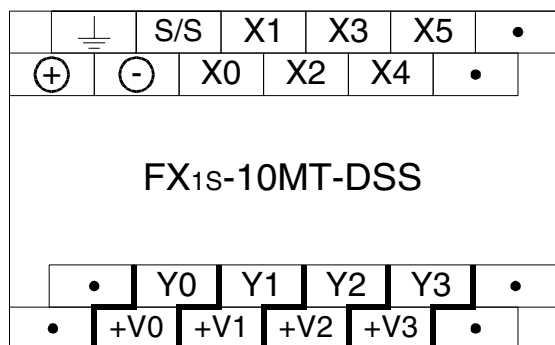

- 1
- 2
- 3
- 4
- 5
- 6
- 7

2.4 FX1s-**MT-ESS/UL

Figure 2.4: Terminal Layouts, Transistor Outputs, AC Power

	⏏	S/S	X1	X3	X5	•
L	N	X0	X2	X4	•	
FX1s-10MT-ESS/UL						
	0V	Y0	Y1	Y2	Y3	•
24V	+V0	+V1	+V2	+V3	•	

	⏏	S/S	X1	X3	X5	X7	X11	X13
L	N	X0	X2	X4	X6	X10	X12	
FX1s-20MT-ESS/UL								
	0V	Y0	Y1	Y2	Y3	Y4	Y6	•
24V	+V0	+V1	+V2	+V3	+V4	Y5	Y7	

	⏏	S/S	X1	X3	X5	X7
L	N	X0	X2	X4	X6	
FX1s-14MT-ESS/UL						
	0V	Y0	Y1	Y2	Y4	•
24V	+V0	+V1	+V2	Y3	Y5	

	⏏	S/S	S/S	X1	X3	X5	X7	X11	X13	X15	X17
L	N	S/S	X0	X2	X4	X6	X10	X12	X14	X16	
FX1s-30MT-ESS/UL											
	0V	Y0	Y1	Y2	Y4	+V3	Y7	Y11	Y12	Y14	•
24V	+V0	+V1	+V2	Y3	Y5	Y6	Y10	+V4	Y13	Y15	

3. Installation Notes

The installation of FX_{1S} products has been designed to be safe and easy. When the products associated with this manual are used as a system or individually, they must be installed in a suitable enclosure. The enclosure should be selected and installed in accordance to the local and national standards.

1

2

3

4

5

6

7

3.1 Product Outline

Figure 3.1: Features of the FX1s PLC

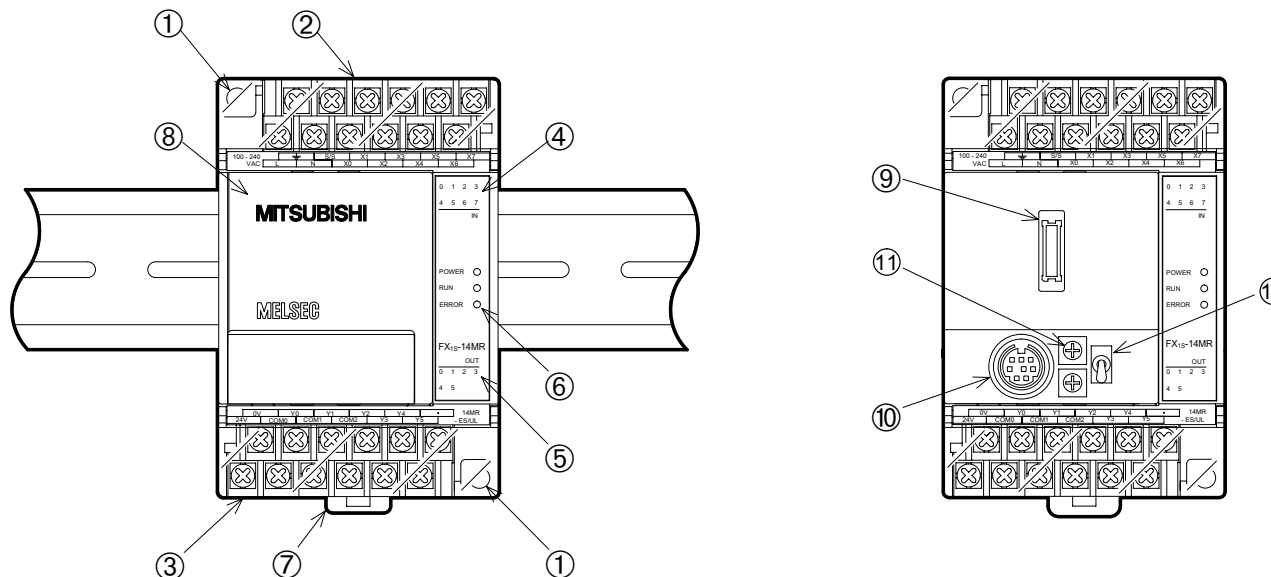

Table 3.1: Feature Table

1	Direct Mounting Holes (4.5 mm<0.17"> Diameter)	7	DIN Rail Mounting Clip
2	Input Terminals (24V DC) and Power Supply Terminals	8	Top Cover
3	Output Terminals and Power Supply Source Terminals	9	Optional Equipment port - Memory Cassette, FX1N-232, 422, 485, 8AV, and CNV BDs, FX1N-5DM
4	Input LED Status Indicators	10	Programming Port
5	Output LED Status Indicators	11	Analog Trim Pots. D8030 read from VR1, the top trim pot. D8031 read from VR2, the bottom trim pot.
6	PLC Status Indicators (POWER, RUN, ERROR)	12	Run/Stop Switch

3.2 FX1s RUN/STOP Control

RUN or STOP of the FX1s can be controlled by:

- ❶ The RUN/STOP switch mounted next to the programming port.
- ❷ A standard input (X0 to X17) defined by the system parameters.
- ❸ Remotely from a personal computer or other programming peripheral.



Note: The FX1s RUN/STOP switch works in parallel with the RUN input terminal. Please refer to Table 3.2.

During remote operation the FX1s RUN/STOP status is determined by the most recently operated control.

E.g. If the RUN/STOP switch is in RUN and a remote STOP is made from a personal computer, the PLC can only be restarted with the RUN/STOP switch by first moving the switch to STOP and then back to RUN.

Figure 3.2: RUN/STOP Input Wiring Diagram

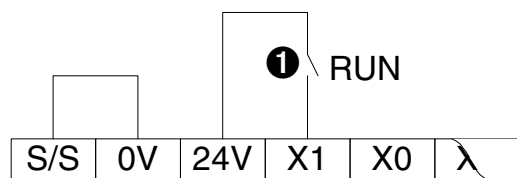

Table 3.2: Run Status Table

RUN/STOP SWITCH	❶ RUN INPUT TERMINAL	FX1s MPU STATUS
✓	✓	RUN
✓	x	RUN
x	x	STOP
x	✓	RUN



3.3 General Specifications

Table 3.3: General Specifications

Item	Description
Operating Temperature	0 to 55 °C (32 to 131 °F)
Storage Temperature	-20 to 70 °C (-4 to 158 °F)
Operating Humidity	35 to 85% Relative Humidity, No condensation
Storage Humidity	35 to 90% Relative Humidity, No condensation
Vibration Resistance - Direct Mounting	Conforms to EN 68-2-6; 10 - 57 Hz: 0.075 mm Half Amplitude 57 - 150 Hz: 9.8 m/s ² Acceleration Sweep Count for X, Y, Z: 10 times (80 min. in each direction)
Vibration Resistance - DIN Rail Mounting	Conforms to EN 68-2-6; 10 - 57 Hz: 0.035 mm Half Amplitude 57 - 150 Hz: 4.9 m/s ² Acceleration Sweep Count for X, Y, Z: 10 times (80 min. in each direction)
Shock Resistance	Conforms to EN 68-2-27: 147m/s ² Acceleration, Action Time: 11 ms 3 times in each direction X, Y, and Z
Noise Immunity	1000 Vp-p, 1microsecond, 30 - 100 Hz, tested by noise simulator
Dielectric Withstand Voltage	AC PSU: 1500 VAC > 1 min., tested between all points, terminals, and ground
	DC PSU: 500 VAC > 1 min., tested between all points, terminals and ground
Insulation Resistance	5 MΩ > at 500 V DC, tested between power terminals and ground
Ground	Grounding resistance 100Ω or less
Certification	UL/cUL (UL508)
EC Directive	EMC(EN61000-6-2, EN50081-2), LVD(EN61010-1)

3.4 PLC Mounting Arrangements

To prevent a rise in temperature, mount the units to walls. Never mount them to the floor or ceiling of an enclosure.

Figure 3.3: PLC Mounting Diagram

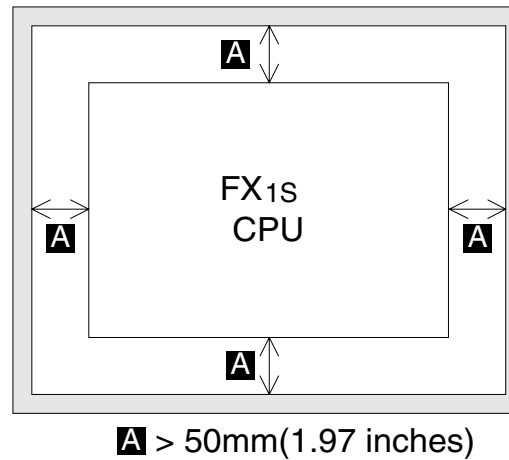

1

2

3

4

5

6

7



Caution

- Units should not be installed in areas subject to the following conditions: excessive or conductive dust, corrosive or flammable gas, moisture or rain, excessive heat, regular impact shocks or excessive vibration.
- Take special care not to allow debris to fall inside the unit during installation e.g. cut wires, shavings etc. Once installation is complete remove the protective paper band to prevent overheating.
- Always ensure that mounted unit is kept as far away as possible from high-voltage cables, high-voltage equipment and power equipment.
- Do not lay signal cables near high voltage power cabling or cabinet housing along the same trunking duct. Effects of noise or surge induction may occur. Keep signal cables of more than 100 mm (3.94") away from these power cables.
- Install necessary power supply cut off precautions to the enclosure of the final system. Attach a warning label (hazard symbol 417-IEC-5036) concerning electric shock to the enclosure.
- Use the FX1S series PLC with consideration for electrical noise in an environment that does not exceed conditions provided by EN50081-2 and EN61000-6-2.
- Cut off all phases from the power source before installation or performing wiring work to avoid electric shock. Incorrect operation can lead to serious damage to the product.
- Cut off all phases from the power source before installing/removing extension or communication cables to modules to avoid electric shock, incorrect operation or serious damage to the product.

- Replace the terminal cover provided, after installation or wiring work is completed, and before supplying power and operating the unit to avoid electric shock.
- After reading the manual's safety instructions, initiate the operation for making program changes while the PLC is in RUN mode, forcing ON/OFF, and switching RUN/STOP.
- DO NOT use the “●” terminal in PLC.
- When using an incorrect power source or performing incorrect operation, serious damage will occur regardless of the level of the voltage and frequency.
- When performing incorrect wiring or operation, serious damage will occur.
- The “L” and “N” terminals are not reversible.
If the “L” and “N” terminals are reversed, the units may be seriously damaged.
- The “24V” and “0V” terminals are not reversible.
If the “24V” and “0V” terminals are reversed, the units may be seriously damaged.
- During transportation avoid any impact as the PLC is a precision instrument.
It is necessary to check the operation of PLC after transportation, in case of any impact damage.
- When storing the PLC, conform to the environmental conditions specified by the general specification.

1

2

3

4

5

6

7

3.5 DIN Rail Mounting

Units can be snap mounted to 35mm(1.37") DIN rail (DIN EN 50022). To release, pull the spring loaded clips away from the rail and slide the unit off and up.

3.6 Direct Mounting

Table 3.4: Hole positions

UNIT		mm ± 0.2	inches ± 0.01
		A = W-8mm (0.32")	
FX1S-10M☆	2-∅ (→)	52	2.05
FX1S-14M☆		52	2.05
FX1S-20M☆		67	2.64
FX1S-30M☆		92	3.63

∅ = 4.5 mm (0.17")

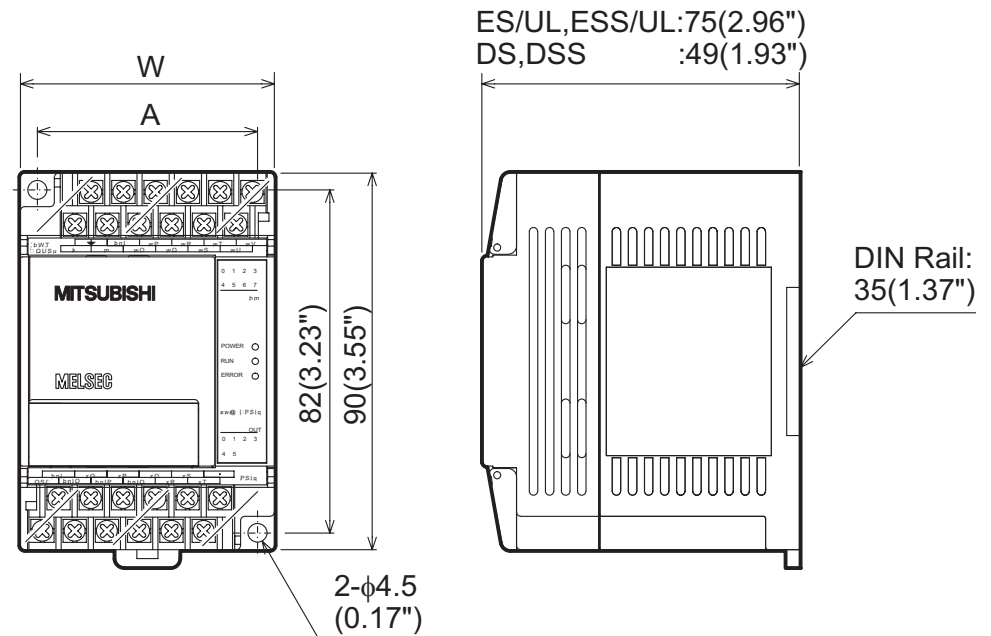

3.7 Termination of Screw Terminals

Terminal screws should be tightened to between 0.5 to 0.8 N·m. Terminal screws must be secured to prevent a loose connection thus avoiding a malfunction.

The terminal screws for the FX1S Series PLC are M3.0. The crimp style terminal (see Figure 3.4 and 3.6) is suitable for use with these screws and should be fitted to the cable for wiring.

When installing 1 or 2 crimp terminals to a terminal, see explanation Figure 3.5 and 3.7.

However, 3 crimp terminals or more should not be installed to a single terminal.

1

2

3

4

5

6

7

- 1) Handle the crimp terminal of the following size when 1 wire is used per terminal. Refer to Figure 3.5 for installation instructions.

Figure 3.4: Crimp Terminal for M3 Screws



Figure 3.5: Installing 1 wire Per a Terminal

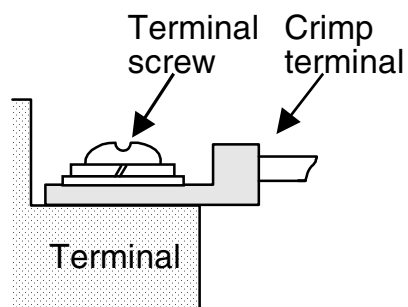

- 2) Handle the crimp terminal of the following size when 2 wires are used per terminal. Refer to Figure 3.7 for installation instructions.

Figure 3.6: Crimp Terminal for M3

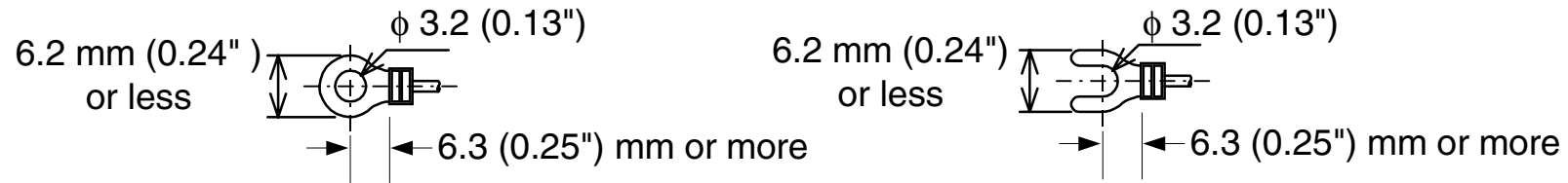
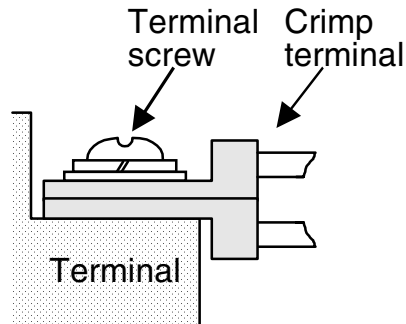

Figure 3.7: Installing 2 Wires Per a Terminal



1

2

3

4

5

6

7

3.8 Installing Optional Units

3.8.1 Expansion Boards

The following is a generic explanation of how to install an expansion board onto the FX1S PLC. For greater detail and specifications of each optional unit, please see the relevant products manual.

MODEL	USE WITH FX1N-5DM	USE WITH FX1N-EEPROM-8L
FX1N-232-BD	✓	Possible for program upload and download while the PLC is in the STOP mode.
FX1N-422-BD	✓	
FX1N-485-BD	✓	
FX1N-CNV-BD	✓	
FX1N-8AV-BD	✓	
FX1N-4EX-BD	✓	
FX1N-2EYT-BD	✓	
FX1N-2AD-BD	✗	✗
FX1N-1DA-BD	✗	✗

Always make sure the power is turned off, before installing a special function board. Only one board can be used at one time, do not try to stack multiple boards.

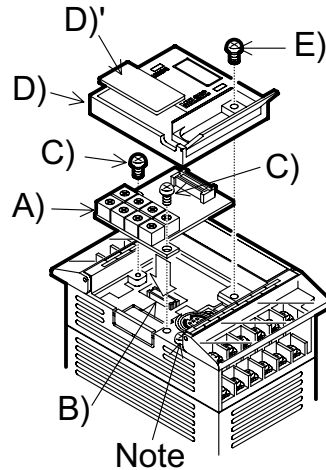

- A) Special function or optional equipment board.
 - B) Optional equipment connector port.
 - C) M3 screw to secure board.
 - D) Top cover for board.
 - E) M3 screw to secure top cover.
- Note: Do not remove this screw.

- Remove base unit top cover.
- Plug board A) into connector B).
- Fix board to base unit using screws C).
- Attach top cover for board D) removing section D)' to expose connector etc. (if applicable)
- Secure top cover with M3 screw E).

1

2

3

4

5

6

7

3.8.2 FX_{1N}-5DM Display Module

Always make sure the power is turned off, before installing the 5DM.

- A) Top cover for DM
- B) Optional equipment connector.
- C) M3 screw to secure top cover.

- Remove the base unit top cover.
- Attach the top cover for DM A), and secure with screw C) (if 5DM is to be permanently mounted)
- Plug in the 5DM at connector B)

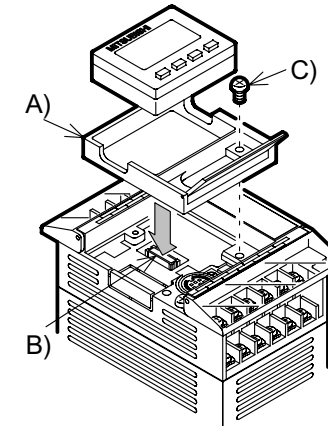

For further information please refer to the FX_{1N}-5DM user's manual.

4. Power Supply

4.1 Wiring Techniques

Wiring for FX1S products has been designed to be safe and easy. If the user is concerned about the correct installation of these products or associated products, please contact a professional electrician who is trained to the local and national standards applicable to the installation site.

4.2 Wiring Cautions



- Do not run input signals in the same multicore cable as output signals or allow them to share the same wire.
- Do not lay I/O signal cables next to power cables or allow them to share the same trunking duct. Low voltage cables should be reliably separated or insulated with regard to high voltage cabling.
- Where I/O signal lines are used over an extended distance consideration for voltage drop and noise interference should be made.

1

2

3

4

5

6

7

4.3 Power Supply



- When wiring an AC supply, the “Live” cable should be connected to the “L” terminal and the “Neutral” cable should be connected to the “N” terminal. Do NOT connect the “Live” wire to the “N” terminal, otherwise, the user may receive a dangerous shock upon powerup.
- When wiring a DC supply, the “Live” cable should be connected to the “+” terminal and the “Neutral” cable should be connected to the “-” terminal. Do NOT connect the “Live” wire to the “-” terminal, otherwise, the user may receive a dangerous shock upon powerup.

4.4 Power Supply Characteristics

Table 4.1: AC Input Power Requirements, FX1S-M*-ES/UL, ESS/UL**

Description	FX1S-10M	FX1S-14M	FX1S-20M	FX1S-30M
Power supply	100 - 240V AC, +10% -15%, 50/60 Hz			
Max. allowable momentary power failure period	10ms; if less than 10ms, the PLC will continue operation. If 10ms or more, the PLC will shut down			
Fuse (size) rating	250V 1.0A			
In-rush current	100V AC - Max. 15A for 5ms 200V AC - Max. 25A for 5ms			
Power consumption	19W ^{*1}	19W ^{*1}	20W ^{*1}	21W ^{*1}
24V DC Service Supply	400 mA			

*1 Includes the input current (5 or 7mA per point).

Table 4.2: DC Input Power Requirements, FX1S-M*-DS, DSS**

Description	FX1S-10M	FX1S-14M	FX1S-20M	FX1S-30M
Power supply	24 V DC +10% -15%			
Max. allowable momentary power failure period	5 ms; If less than 5 ms, the PLC will continue operation. If 5 ms or more, the PLC will shut down			
Fuse rating	0.8A			
In-rush current	15A for 0.1 ms			
Power consumption ^{*1}	6W	6.5W	7W	8W

*1 Includes the input current (5 or 7mA per point).

4.5 Power Supply Wiring

Figure 4.1: AC Power Supply Example Wiring

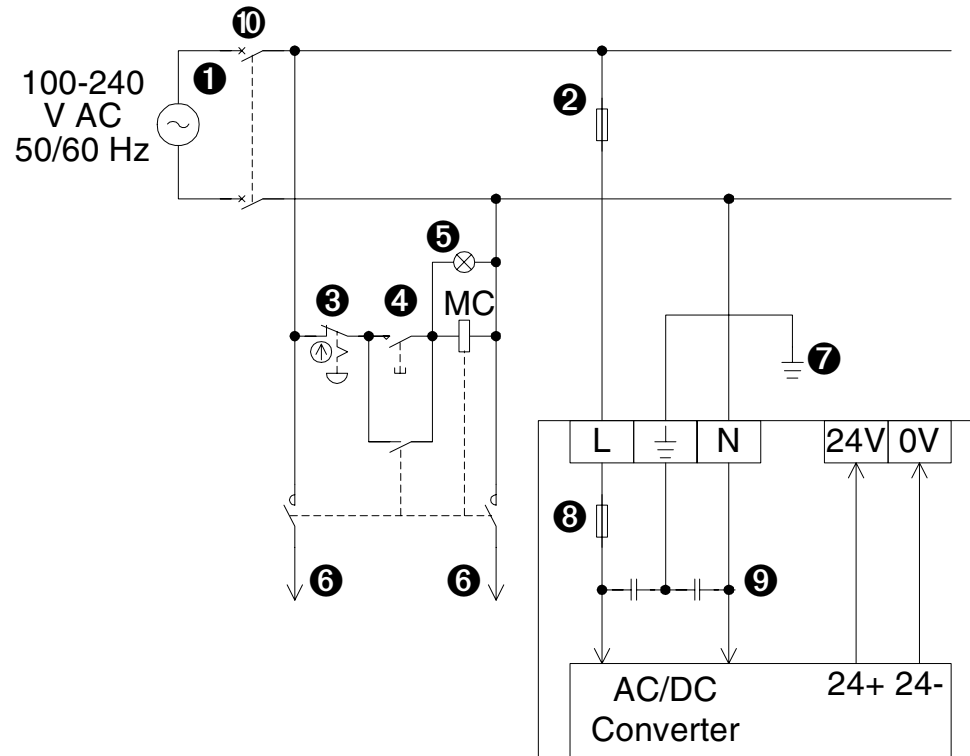

①	Power supply 100 - 240V AC, +10% -15%, 50/60 Hz
②	Circuit protector or Fuse
③	Emergency stop
④	Power supply switch
⑤	Power ON pilot indicator
⑥	Power supply for loads
⑦	Grounding resistor 100Ω or less
⑧	Fuse
⑨	Main unit
⑩	Breaker

Figure 4.2: DC Power Supply Example Wiring

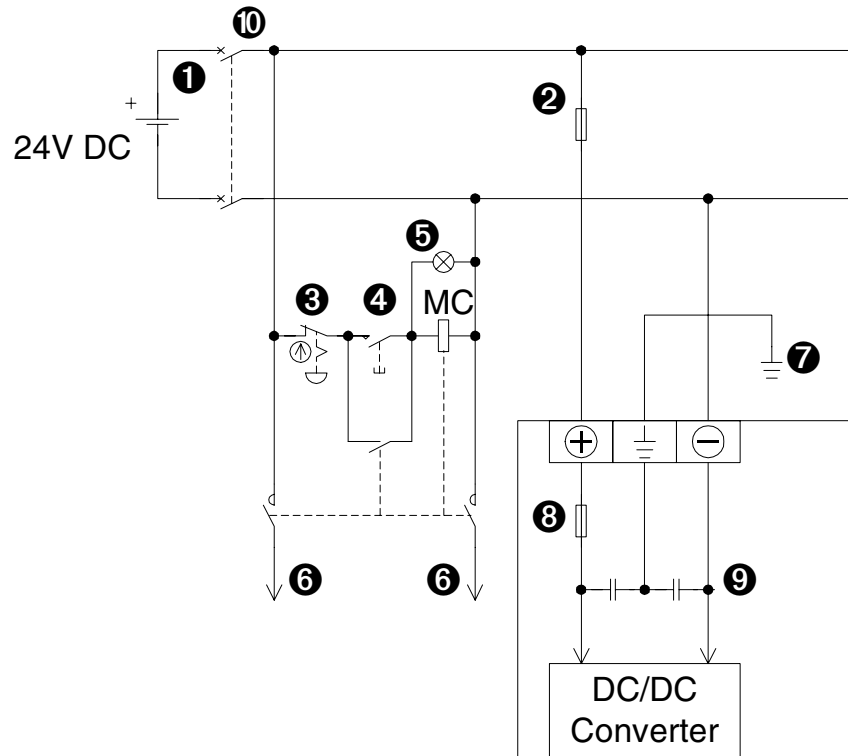

①	Power supply 24V DC, +10% -15%
②	Circuit protector or Fuse
③	Emergency stop
④	Power supply switch
⑤	Power ON pilot indicator
⑥	Power supply for loads
⑦	Grounding resistor 100Ω or less
⑧	Fuse
⑨	Main unit
⑩	Breaker

1

2

3

4

5

6

7

4.6 Service Power supply

An AC powered FX1S can supply a service current of 24V DC at 400mA.

A DC powered FX1S does not have the capacity to supply a service current.

4.7 Earthing / Grounding



Use a cable at least 0.2mm^2 (AWG24) to ground equipment. Ground resistance must be less than 100Ω . Note that the ground cable must not be connected to the same ground as the power circuits. Grounding is recommended but if a proper ground cannot be provided the PLC will still operate correctly without the use of a ground.

5. Inputs

5.1 24V DC Input Specifications

Table 5.1: FX1s Input Specifications

		FX1s Main Unit	
		X0 - X7	X10 - X17
Input voltage		24V DC +/- 10%	
Input current		24V DC, 7mA	24V DC, 5mA
Input switching current	OFF → ON	>4.5mA	>3.5mA
	ON → OFF	<1.5mA	
Response time		10ms (default)	
Variable response time		0 - 15ms for X000-X017 via use of the FX1s digital filter.	
Circuit isolation		Photocoupler	
Operation indication		LED is lit	

1

2

3

4

5

6

7

5.2 Wiring Diagrams

5.2.1 Input Wiring

Figure 5.1: Input Wiring Diagrams

FX_{1S}-Source

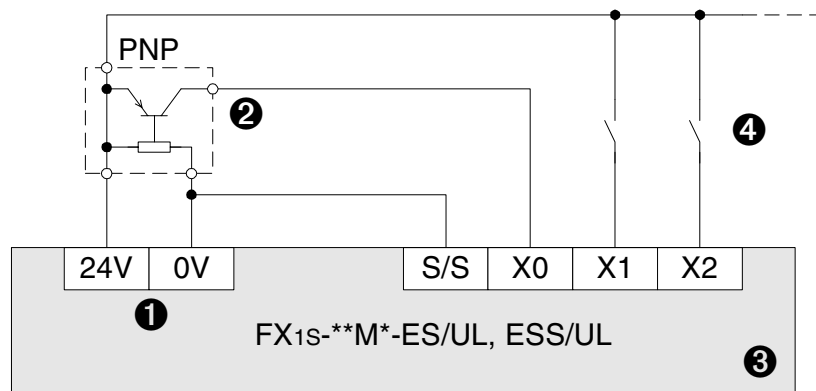

FX_{1S}-Sink

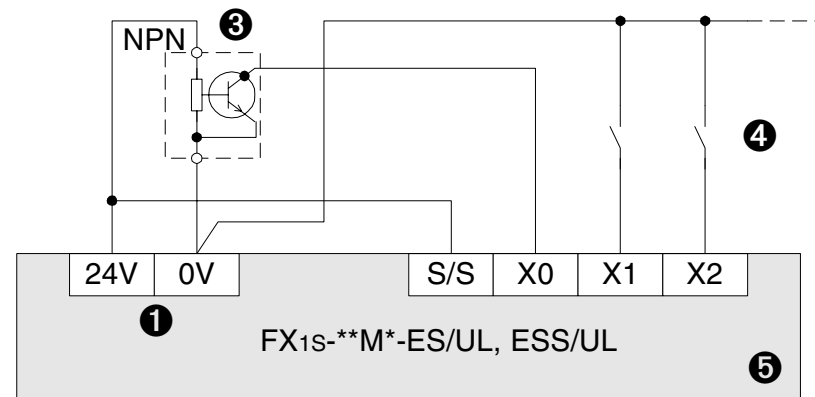

①	24V DC Service Supply
②	PNP Sensor
③	NPN Sensor
④	Input Device Contact
⑤	FX _{1S} Controller Main Body

5.2.2 Input Circuit Connection

Figure 5.2: Input Circuit Diagrams (Source/Sink)

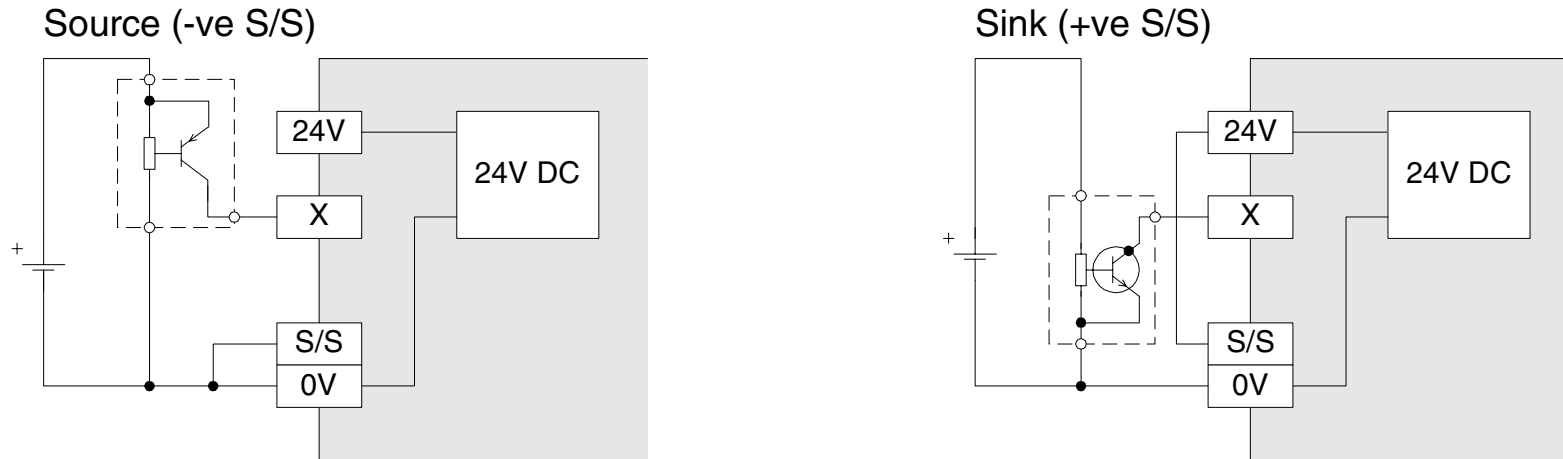

5.2.3 Diodes and Inputs Connected in Series

Figure 5.3: Diode Connection Diagram

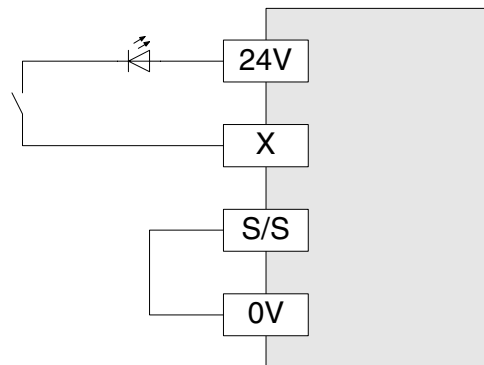

Voltage drop across the diode is Max. 4V.
No more than 2 LEDs should be connected in series.

- 1
- 2
- 3
- 4
- 5
- 6
- 7

5.2.4 Resistors and Inputs Connected in Parallel

Parallel resistance R_p : $FX_{1s} = 15k\Omega$. If resistance R_p is less than the stated value, then add the R_b value using the Equation 1 calculation.

Alternatively; Current leakage: $FX_{1s} = 1.5mA$. If the current leakage is greater than the stated value, then add the R_b value using the equation 2 calculation.

Figure 5.4: Parallel LED Diagram

$$\text{Eqn 1 : } R_b \leq \frac{4R_p}{15 - R_p}$$

$$\text{Eqn 2 : } R_b \leq \frac{6}{I - 1.5}$$

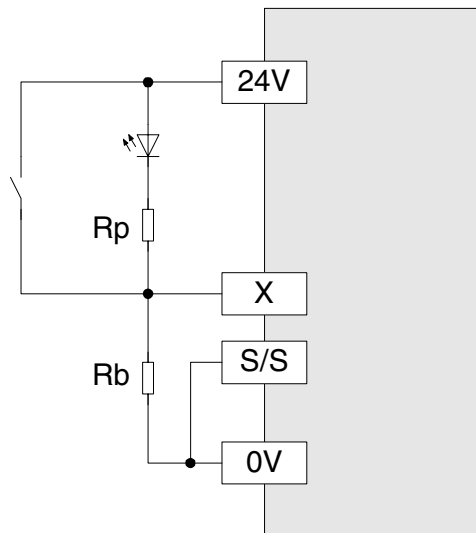

6. Outputs

6.1 Output Specifications

Table 6.1: Output Specifications

Description		Relay Output	Transistor Output
Switched voltages (resistive load)		≤ 240V AC, ≤ 30V DC	5 - 30V DC
Rated current / N points (resistive load)		2A/1 point, 8A/COM	0.5A/1 point, 0.8A/COM
Max. Inductive load		80VA, 120/240 VAC, See table 6.2 for more details	12W/24V DC
Max. Lamp load (tungsten load)		100W (1.17A/85V AC, 0.4A/250V AC)	0.9W/24V DC
Minimum load		When supply voltage < 5V DC allow at least 2mA flow	-
Response time (approx.)	OFF → ON	10ms	< 0.2ms; <5μs (Y0,Y1 only)
	ON → OFF	10ms	< 0.2ms (I > 0.2 A); <5μs (Y0,Y1 only)
Circuit isolation		By Relay	PhotoCoupler
Open circuit current leakage		-	0.1mA/30V DC
Operation indication		LED is lit when coil is energized	
Output protection	Internal device	None	
	Outside device (Fuse)	Rated value according to the load.	

1

2

3

4

5

6

7

6.2 Relay Output Example

Figure 6.1: Typical Relay Wiring Diagram

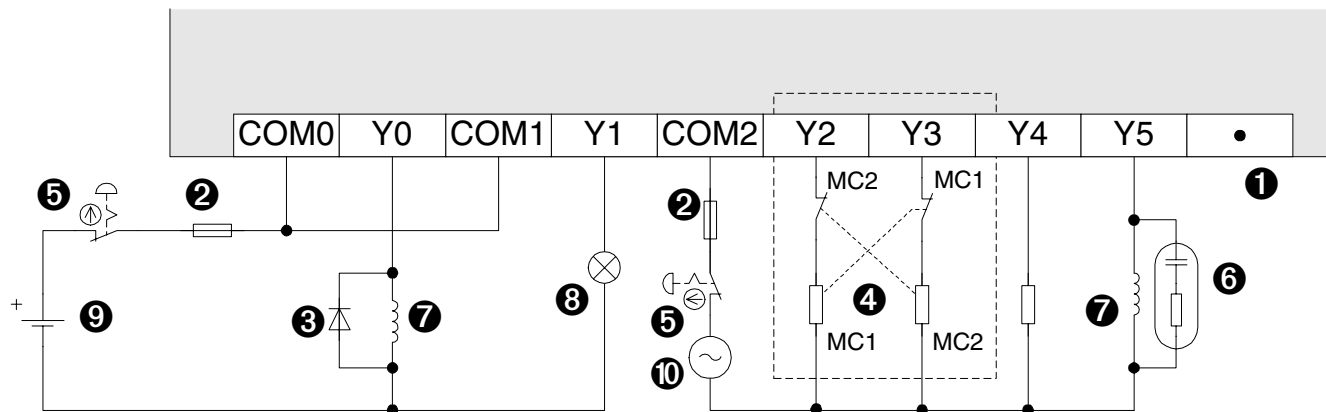

①	Do not use this terminal
②	Fuse
③	Reverse-current protection diode (See section 6.4)
④	External Mechanical Interlock
⑤	Emergency Stop
⑥	Surge absorber (0.1µF capacitor + 100-120Ω resistor) (See section 6.4)

⑦	Inductive load
⑧	Incandescent Lamp
⑨	DC Power Supply
⑩	AC Power Supply

6.2.1 Reliability Tests



The test results in Table 6.2 were gathered from a 1 sec ON/OFF test cycle. Please note that the over current induced by in-rush greatly reduces the relay contact's service life. The rated life for an inductive AC load such as a contactor or solenoid valve is 500,000 operations at 20VA.

Table 6.2: Relay Life Cycle Data

Description	20VA	35VA	80VA
Load capacity	0.2A/100VAC 0.1A/200VAC	0.35A/100V AC 0.17A/240V AC	0.8A/100V AC 0.4A/240V AC
Life of contact (cycles)	3,000,000	1,000,000	200,000
Example load (Mitsubishi contactor)	S-K10 ~ S-K95	S-K100 ~ S-K150	S-K180,S-K400

1

2

3

4

5

6

7

6.3 Transistor Output Examples

Figure 6.2: Transistor Output Wiring Diagram

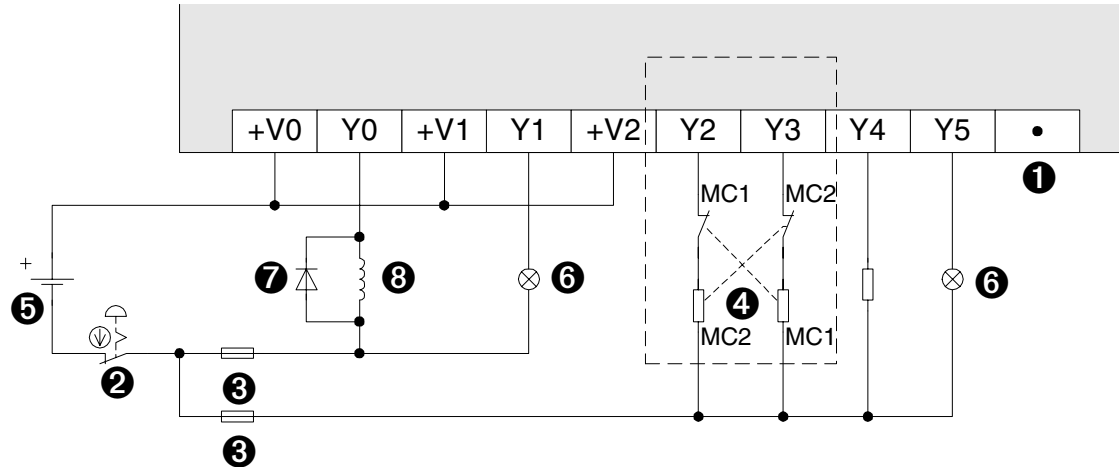

①	Do not use this terminal
②	Emergency Stop
③	Fuse
④	External Mechanical Interlock (See Section 6.4)
⑤	DC Power Supply
⑥	Reverse-current protection diode (See Section 6.4)
⑦	Inductive load

Figure 6.3: Japanese Model Transistor Output

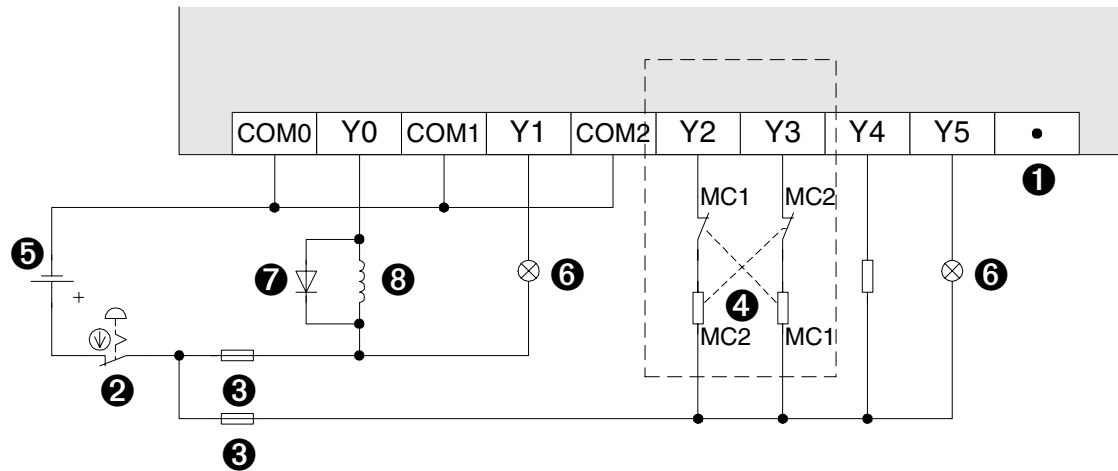

6.3.1 Response Times

OFF times increase as the load current decreases.

For improved response times use a 'dummy' resistor, see Figure 6.4. If a response time of 0.5 ms or better is required when using 'light loads' use a 'dummy' resistor and ensure the signal line has a current greater than 60mA/24V DC.

Figure 6.4: Dummy load

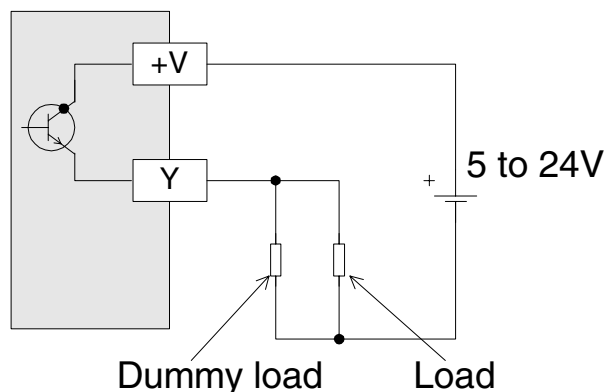

Y000 and Y001 are high speed response outputs with the following characteristics:
10 - 100 mA at 5 - 24V DC, 100 kHz maximum output signal.

If the high speed response is required, a current of 10 - 100mA must be used.

1

2

3

4

5

6

7

6.4 Applying Safe Loads



Caution for DC Loads

1) Relay output case

This PLC does not have any internal protection circuitry on the relay outputs. For switching direct current on inductive loads, a reverse-current protection diode should be installed in parallel with the load. The relay contact life decreases significantly if this is not done.

The reverse-current protection diode needs to satisfy the following specifications.

- The diode is rated for maximum reverse voltage of 5 to 10+ times the load voltage.
- The forward current is more than the load current.

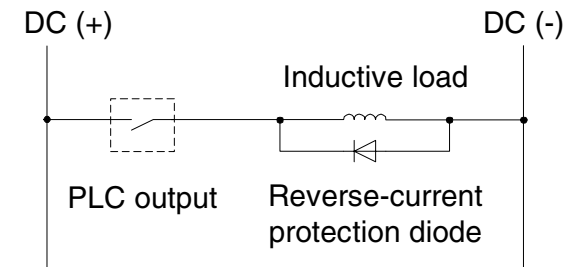

2) Transistor output case

Transistor outputs use internal zener diode (50V) as protection circuitry. When driving the inductive load with transistor output, a reverse-current protection diode can be installed in parallel with the load if necessary.

The reverse-current protection diode needs to satisfy the following specifications.

- The diode is rated for maximum reverse voltage of 5 to 10+ times the load voltage.
- The forward current is more than the load current.

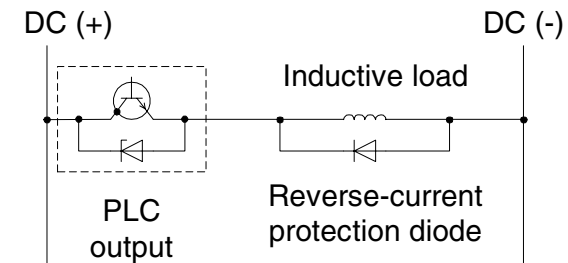

Caution for AC Loads



1) Relay output case

This PLC does not have any internal protection circuitry on the relay outputs. For switching AC on inductive loads, a surge absorber (0.1 μ F + “100 to 120 Ω ”) should be installed in parallel with the load. The relay contact life decreases significantly if this is not done.

Besides protecting the internal circuitry of the PLC, a surge absorber decreases the noise emissions to the load.

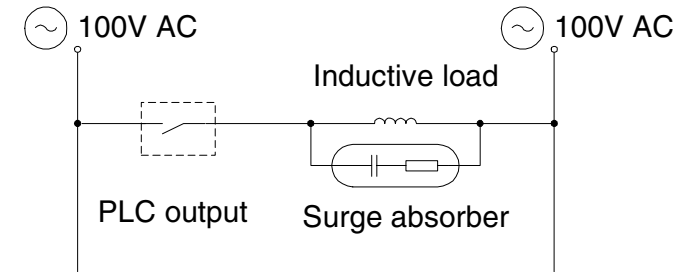

Component Side of Loads

The output contact of the PLC should be connected to components consistently as indicated in the figure

Note: If using another output type, please replace symbol with appropriate symbol.

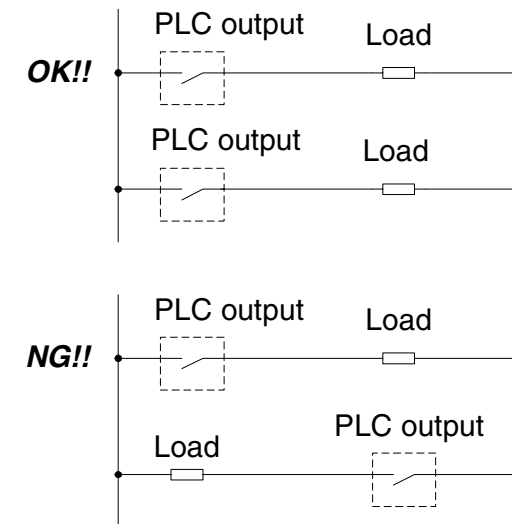

1
2
3
4
5
6
7



Mechanical Interlock

Ensure all loads are applied to the same side of each PLC output, see previous figures. Loads which should NEVER simultaneously operate (e.g. direction control of a motor), because of a critical safety situation, should not rely on the PLC's sequencing alone. Mechanical interlocks MUST be fitted to all critical safety circuits. (See proceeding figure.)

Note: If using another output type, please replace symbol with appropriate symbol.

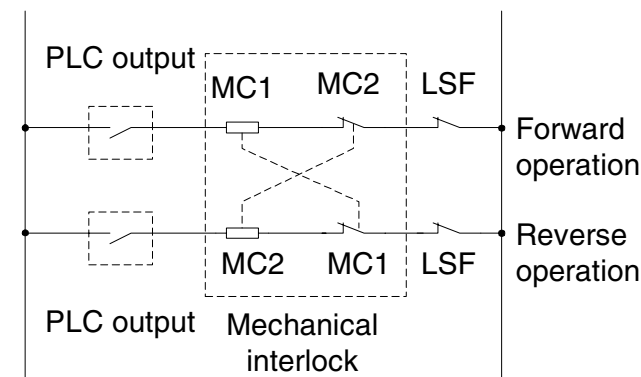

7. Diagnostics

7.1 Preliminary Checks

Table 7.1: Preliminary Checks

POWER <input type="checkbox"/> RUN <input type="checkbox"/> ERROR <input type="checkbox"/>	Check power supply, ground and I/O cables are wired correctly.
POWER <input checked="" type="checkbox"/> RUN <input type="checkbox"/> ERROR <input type="checkbox"/>	Turn the power supply on. Check that the power LED is lit. Down load a small test program to the PLC. Verify the program to ensure it has been written to the PLC correctly. Using the programming device, force each output ON/OFF. Check the output LEDs for operation.
POWER <input checked="" type="checkbox"/> RUN <input checked="" type="checkbox"/> ERROR <input type="checkbox"/>	Put the PLC into RUN. Check the RUN LED is lit. Check that the previously down loaded program works correctly. Once all checks are complete take the PLC out of run and turn OFF the power supply.
	During this testing stage take extreme care not to touch any live or hazardous parts.

1

2

3

4

5

6

7

7.2 ERROR LED ON (CPU ERROR)

Table 7.2: Error LED Checks

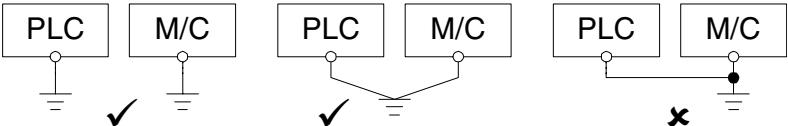
POWER ■ RUN □ ERROR ■	Fault ERROR LED ON	Remedy Reset PLC. Turn power OFF, then ON and trigger RUN input.	Possible results	LED OFF	Has the memory cassette been installed or removed while the unit was still powered On?
				LED is lit	A
A	Remedy Power OFF Disconnect earth/ground terminal Power ON	Possible results	LED is lit	B	LED is flashing Check for programming error. Ensure the earth/ ground cable is correctly rewired. 
B	Remedy Possible program/scan time error. Check D8012 for program scan time, (units 0.2 ms must be less than 0.2 sec, i.e. - data value <2000).		Possible results D8012 > D8000		

7.3 Common Errors

- Corroded contact points at some point in an I/O line.
- An I/O device has been used outside its specified operating range.
- An input signal occurs in a shorter time period than that taken by one program scan.

7.4 Maintenance

- Check interior temperature of the panel.
- Check panel air filters if fitted.
- Check for loosening of terminals or mounting facilities (due to vibration).

1

2

3

4

5

6

7

7.5 Operation and Error Flags

Table 7.3: Operation and Error Flags

M8004 (ref. 8004)	Error occurrence (ON when M8060-7 are ON)
M8035	Forced RUN mode
M8036	Forced RUN signal
M8037	Forced STOP signal
M8039 (ref. D8039)	Constant scan mode

M8061 (ref. D8061)	PLC hardware error
M8063 (ref. D8063)	Parallel link error
M8064 (ref. D8064)	Parameter error
M8065 (ref. D8065, D8069)	Syntax error
M8066 (ref. D8066, D8069)	Program (circuit) error
M8067 (ref. D8067, D8069)	Program execution error
M8068 (ref. D8068)	Execution error latch

7.6 PLC Status Registers

Table 7.4: PLC Status Registers

D8000 (default 200msec)	Watchdog timer
D8001	PLC version 22100 = FX1S Version 1.00 22 = FX1S, 100 = Version 1.00
D8002	Memory capacity 0002=2K steps
D8003	Memory type 02H=EEPROM protect switch OFF 0AH=EEPROM protect switch ON 10H=MPU memory
D8004	Error flag number 8060=M8060, (8060-8068)

1

2

3

4

5

6

7

7.7 Error Registers

Table 7.5: Error Registers

D8061	Error code for PLC hardware error
D8063	Error code for parallel link fault
D8064	Parameter error code
D8065	Syntax error code
D8066	Program (circuit) error code
D8067	Program execution error code
D8068	Latched step number of execution error
D8069	Step number of errors associated with error flags M8065-M8067

7.8 Error Codes

Table 7.6: Error Codes

D8061		Check cable connections
	0000	No error
	6101	RAM error
	6102	Operation circuit error
	6103	I/O bus error (M8069 = ON)
D8062		Check the programmer / PLC connections
	0000	No error
	6201	Parity/overrun/framing error
	6202	Character error
	6203	Data sum check error
	6204	Data format error
	6205	Command error

D8063		Check both power and communications connections
	0000	No error
	6301	Parity/overrun/framing error
	6302	Character error
	6303	Data sum check error
	6304	Data format error
	6305	Command error
	6306	Watchdog timer error

1

2

3

4

5

6

7

7.9 Instruction List

Table 7.7: Numerically Sorted

		0	1	2	3	4	5	6	7	8	9
000	PROGRAM FLOW	CJ	CALL	SRET	IRET	EI	DI	FEND	WDT	FOR	NEXT
010	TRANSFERS, COMP	CMP	ZCP	MOV			BMOV			BCD	BIN
020	+×÷, LOGICS	ADD	SUB	MUL	DIV	INC	DEC	WAND	WOR	WXOR	
030	SHIFT					SFTR	SFTL			SFWR	SFRD
040	DATA OPERATION 1	ZRST	DECO	ENCO							
050	HIGH-SPEED	REF		MTR	HSCS	HSCR		SPD	PLSY	PWM	PLSR
060	HANDY INSTR. 1	IST		ABSD	INCD			ALT	RAMP		
070	FX I/O DEVICES			DSW		SEGL					
080	FX SERIAL DEVICES	RS	PRUN	ASCI	HEX	CCD	VRRD	VRSC		PID	
150	POSITIONING						ABS	ZRN	PLSV	DRVI	DRVA
160	REAL TIME CLOCK	TCMP	TZCP	TADD	TSUB			TRD	TWR		HOUR
220	IN-LINE COMPARE					LD=	LD>	LD<		LD≠	LD≤
230		LD≥		AND=	AND>	AND<		AND≠	AND≤	AND≥	
240		OR=	OR>	OR<		OR≠	OR≤	OR≥			

Table 7.8: Alphabetically sorted

	Symbol	FNC No.	D	P
A	ABS	155		
	ABSD	062		
	ADD	020		
	ALT	066		
	AND□	232-238		
	ASCI	082		
B	BCD	018		
	BIN	019		
	BMOV	015		
C	CALL	001		
	CCD	084		
	CJ	000		
	CMP	010		

	Symbol	FNC No.	D	P
D	DEC	025		
	DECO	041		
	DI	005		
	DIV	023		
	DRVA	159		
	DRVI	158		
	DSW	072		
E	EI	004		
	ENCO	042		
F	FEND	006		
	FOR	008		

	Symbol	FNC No.	D	P
H	HEX	083		
	HOUR	169		
	HSCR	054		
	HSCS	053		
I	INC	024		
	INCD	063		
	IRET	003		
	IST	060		
L	LD□	224-230		
M	MOV	012		
	MTR	052		
	MUL	022		
N	NEXT	009		
O	OR□	240-246		

- 1
- 2
- 3
- 4
- 5
- 6
- 7

	Symbol	FNC No.	D	P
P	PID	088		
	PLSR	059		
	PLSV	157		
	PLSY	057		
	PRUN	081		
	PWM	058		
	RAMP	067		
R	REF	050		
	RS	080		
	SEGL	074		
S	SFRD	039		
	SFTL	035		
	SFTR	034		

	Symbol	FNC No.	D	P
S	SFWR	038		
	SPD	056		
	SRET	002		
	SUB	021		
	TADD	162		
T	TCMP	160		
	TRD	166		
	TSUB	163		
	TWR	167		
	TZCP	161		

	Symbol	FNC No.	D	P
V	VRRD	085		
	VRSC	086		
W	WAND	026		
	WDT	007		
	WOR	027		
Z	WXOR	028		
	ZCP	011		
	ZRN	156		
	ZRST	040		

7.10 Device List

Table 7.9: Device List

Device Type		Specification	Remarks
Program capacity		2k steps by FX1S internal EEPROM or 2k steps by FX _{1N} -EEPROM-8L	
I/O configuration		Max total I/O set by Main Processing Unit	
Auxiliary relay (M coils)	General	384 points	M0 to M383
	Latched (EEPROM backed-up)	128 points	M384 to M511
	Special	256 points	From the range M8000 to M8255
State relays (S coils)	Latched (EEPROM backed-up)	128 points	S0 to S127
	Initial	10 points (subset)	S0 to S9
Timers (T)	100 msec	63 points Range: 0 to 3,276.7 sec	T0 to T62
	10 msec	31 points Range: 0 to 327.67 sec	T32 to T62 when special M coil M8028 is driven ON
	1 msec	1 point Range: 0.001 to 32.767 sec	T63

1

2

3

4

5

6

7

Device Type		Specification	Remarks
Counters (C)	General	16 points Range: 1 to 32,767 counts	C0 to C15 Type: 16 bit up counter
	Latched (EEPROM backed-up)	16 points Range: 1 to 32,767 counts	C16 to C31 Type: 16 bit up counter
High speed counters (C) Max. 6 points	1 phase	Range: -2,147,483,648 to +2,147,483,647 counts General rule: Select counter combinations with a combined counting frequency of 60kHz or less. Note; all counters are latched (EEPROM backed-up) If high speed counter is used with the HSCS or HSCR instruction, a combined counting frequency of 30kHz or less.	C235 to C240, 6 points
	1 phase c/w start stop input		C241 to C245, 5 points
	2 phase		C246 to C250, 5 points
	A/B phase		C251 to C255, 5 points

Device Type		Specification	Remarks
Data registers (D)	General	128 points	D0 to D127 Type: 16 bit data storage register pair for 32 bit device
	Latched (EEPROM backed-up)	128 points	D128 to D255 Type: 16 bit data storage register pair for 32 bit device
	File	Maximum 1500 points	D1000 to D2499 set by parameter in 3 blocks of 500 program steps Type: 16 bit data storage register
	Externally adjusted	2 points Range: 0 to 255	D8030 & D8031 Data is entered indirectly through the external setting potentiometer
	Special	256 points (inclusive of D8013)	From the range D8000 to D8255 Type: 16 bit data storage register
	Index	16 points	V and Z Type: 16 bit data storage register
Pointers (P)	For use with CALL	64 points	P0 to P63
	For use with interrupts	6 points	I00□ to I50□ (rising trigger □ = 1, falling trigger □ = 0)
Nest levels		8 points for use with MC and MCR	N0 to N7

- 1
- 2
- 3
- 4
- 5
- 6
- 7

Device Type		Specification	Remarks
Constants	Decimal K	16 bit: -32,768 to +32,767 32 bit: -2,147,483,648 to +2,147,483,647	
	Hexadecima I H	16 bit: 0000 to FFFF 32 bit: 00000000 to FFFFFFFF	

1	INTRODUCTION	1
2	TERMINAL LAYOUTS	2
3	INSTALLATION NOTES	3
4	POWER SUPPLY	4
5	INPUTS	5
6	OUTPUTS	6
7	DIAGNOSTICS	7

1	INTRODUCTION
2	TERMINAL LAYOUTS
3	INSTALLATION NOTES
4	POWER SUPPLY
5	INPUTS
6	OUTPUTS
7	DIAGNOSTICS

Truy cập website <https://plcmitsubishi.com> để có thêm nhiều tài liệu và bài viết hướng dẫn kỹ thuật hay
FX1S Series Programmable Controllers

HARDWARE MANUAL

FX1S SERIES PROGRAMMABLE CONTROLLERS



HEAD OFFICE: MITSUBISHI DENKI BLDG MARUNOUCHI TOKYO 100-8310
HIMEJI WORKS: 840, CHIYODA CHO, HIMEJI, JAPAN

MODEL	FX1S-HW-E
MODEL CODE	09R510

JY992D83901G
(MEE)

Effective Mar. 2003
Specifications are subject to change without notice.